Optimization Modeling with LINGO

Sixth Edition

LINDO Systems, Inc.



1415 North Dayton Street, Chicago, Illinois 60622

Phone: (312)988-7422 Fax: (312)988-9065

E-mail: info@lindo.com

TRADEMARKS

What's*Best!* and LINDO are registered trademarks and LINGO is a trademark of LINDO Systems, Inc. Other product and company names mentioned herein are the property of their respective owners.

Copyright © 2006 by LINDO Systems Inc
All rights reserved. First edition 1998
Sixth edition, April 2006
Printed in the United States of America
First printing 2003

ISBN: 1-893355-00-4

Published by



LINDO SYSTEMS INC.

1415 North Dayton Street
Chicago, Illinois 60622
Technical Support: (312) 988-9421
<http://www.lindo.com>
e-mail: tech@lindo.com

Contents

Preface	xiii
Acknowledgments.....	xiii
1 What Is Optimization?	1
1.1 Introduction	1
1.2 A Simple Product Mix Problem.....	1
1.2.1 Graphical Analysis	2
1.3 Linearity	5
1.4 Analysis of LP Solutions.....	6
1.5 Sensitivity Analysis, Reduced Costs, and Dual Prices.....	8
1.5.1 Reduced Costs	8
1.5.2 Dual Prices.....	8
1.6 Unbounded Formulations	9
1.7 Infeasible Formulations	10
1.8 Multiple Optimal Solutions and Degeneracy	11
1.8.1 The “Snake Eyes” Condition.....	13
1.8.2 Degeneracy and Redundant Constraints.....	16
1.9 Nonlinear Models and Global Optimization	17
1.10 Problems.....	18
2 Solving Math Programs with LINGO	23
2.1 Introduction	23
2.2 LINGO for Windows.....	23
2.2.1 File Menu	23
2.2.2 Edit Menu	25
2.2.3 LINGO Menu.....	27
2.2.4 Windows Menu	28
2.2.5 Help Menu.....	29
2.2.6 Summary.....	29
2.3 Getting Started on a Small Problem.....	29
2.4 Integer Programming with LINGO	30
2.4.1 Warning for Integer Programs.....	32
2.5 Solving an Optimization Model.....	32
2.6 Problems.....	33
3 Analyzing Solutions	35
3.1 Economic Analysis of Solution Reports.....	35
3.2 Economic Relationship Between Dual Prices and Reduced Costs.....	35
3.2.1 The Costing Out Operation: An Illustration	36
3.2.2 Dual Prices, LaGrange Multipliers, KKT Conditions, and Activity Costing	37
3.3 Range of Validity of Reduced Costs and Dual Prices	38
3.3.1 Predicting the Effect of Simultaneous Changes in Parameters—The 100% Rule	43
3.4 Sensitivity Analysis of the Constraint Coefficients.....	44

3.5 The Dual LP Problem, or the Landlord and the Renter	45
3.6 Problems.....	47
4 The Model Formulation Process.....	53
4.1 The Overall Process	53
4.2 Approaches to Model Formulation.....	54
4.3 The Template Approach.....	54
4.3.1 Product Mix Problems.....	54
4.3.2 Covering, Staffing, and Cutting Stock Problems.....	54
4.3.3 Blending Problems.....	54
4.3.4 Multiperiod Planning Problems	55
4.3.5 Network, Distribution, and PERT/CPM Models	55
4.3.6 Multiperiod Planning Problems with Random Elements.....	55
4.3.7 Financial Portfolio Models.....	55
4.3.8 Game Theory Models	56
4.4 Constructive Approach to Model Formulation	56
4.4.1 Example	57
4.4.2 Formulating Our Example Problem	57
4.5 Choosing Costs Correctly.....	58
4.5.1 Sunk vs. Variable Costs.....	58
4.5.2 Joint Products	60
4.5.3 Book Value vs. Market Value.....	61
4.6 Common Errors in Formulating Models.....	63
4.7 The Nonsimultaneity Error.....	65
4.8 Problems.....	66
5 The Sets View of the World	69
5.1 Introduction	69
5.1.1 Why Use Sets?	69
5.1.2 What Are Sets?.....	69
5.1.3 Types of Sets	70
5.2 The SETS Section of a Model	70
5.2.1 Defining Primitive Sets.....	70
5.2.2 Defining Derived Sets	71
5.2.3 Summary.....	72
5.3 The DATA Section.....	73
5.4 Set Looping Functions.....	75
5.4.1 @SUM Set Looping Function	76
5.4.2 @MIN and @MAX Set Looping Functions	77
5.4.3 @FOR Set Looping Function.....	78
5.4.4 Nested Set Looping Functions.....	79
5.5 Set Based Modeling Examples.....	79
5.5.1 Primitive Set Example.....	80
5.5.2 Dense Derived Set Example.....	83
5.5.3 Sparse Derived Set Example - Explicit List	85
5.5.4 A Sparse Derived Set Using a Membership Filter	90
5.6 Domain Functions for Variables	94

5.7 Spreadsheets and LINGO	94
5.8 Summary	98
5.9 Problems.....	98
6 Product Mix Problems	99
6.1 Introduction	99
6.2 Example.....	100
6.3 Process Selection Product Mix Problems	103
6.4 Problems.....	108
7 Covering, Staffing & Cutting Stock Models.....	111
7.1 Introduction	111
7.1.1 Staffing Problems.....	112
7.1.2 Example: Northeast Tollway Staffing Problems.....	112
7.1.3 Additional Staff Scheduling Features.....	114
7.2 Cutting Stock and Pattern Selection.....	115
7.2.1 Example: Cooldot Cutting Stock Problem.....	116
7.2.2 Formulation and Solution of Cooldot	117
7.2.3 Generalizations of the Cutting Stock Problem	121
7.2.4 Two-Dimensional Cutting Stock Problems	123
7.3 Crew Scheduling Problems	123
7.3.1 Example: Sayre-Priors Crew Scheduling.....	124
7.3.2 Solving the Sayre/Priors Crew Scheduling Problem	126
7.3.3 Additional Practical Details	128
7.4 A Generic Covering/Partitioning/Packing Model	129
7.5 Problems.....	131
8 Networks, Distribution and PERT/CPM.....	141
8.1 What's Special About Network Models	141
8.1.1 Special Cases	144
8.2 PERT/CPM Networks and LP.....	144
8.3 Activity-on-Arc vs. Activity-on-Node Network Diagrams.....	149
8.4 Crashing of Project Networks	150
8.4.1 The Cost and Value of Crashing.....	151
8.4.2 The Cost of Crashing an Activity	151
8.4.3 The Value of Crashing a Project.....	151
8.4.4 Formulation of the Crashing Problem	152
8.5 Resource Constraints in Project Scheduling	155
8.6 Path Formulations	157
8.6.1 Example	158
8.7 Path Formulations of Undirected Networks.....	159
8.7.1 Example	160
8.8 Double Entry Bookkeeping: A Network Model of the Firm	162
8.9 Extensions of Network LP Models.....	163
8.9.1 Multicommodity Network Flows	164
8.9.2 Reducing the Size of Multicommodity Problems	165
8.9.3 Multicommodity Flow Example	165

8.9.4 Fleet Routing and Assignment.....	168
8.9.5 Fleet Assignment	171
8.9.6 Leontief Flow Models.....	176
8.9.7 Activity/Resource Diagrams.....	178
8.9.8 Spanning Trees.....	180
8.9.9 Steiner Trees.....	182
8.10 Nonlinear Networks	186
8.11 Problems.....	188
9 Multi-period Planning Problems	197
9.1 Introduction	197
9.2 A Dynamic Production Problem.....	199
9.2.1 Formulation	199
9.2.2 Constraints.....	200
9.2.3 Representing Absolute Values.....	202
9.3 Multi-period Financial Models.....	203
9.3.1 Example: Cash Flow Matching	203
9.4 Financial Planning Models with Tax Considerations	207
9.4.1 Formulation and Solution of the WSDM Problem.....	208
9.4.2 Interpretation of the Dual Prices	209
9.5 Present Value vs. LP Analysis.....	210
9.6 Accounting for Income Taxes	211
9.7 Dynamic or Multi-period Networks.....	214
9.8 End Effects	216
9.8.1 Perishability/Shelf Life Constraints	217
9.8.2 Startup and Shutdown Costs	217
9.9 Non-optimality of Cyclic Solutions to Cyclic Problems	217
9.10 Problems.....	223
10 Blending of Input Materials	227
10.1 Introduction.....	227
10.2 The Structure of Blending Problems	228
10.2.1 Example: The Pittsburgh Steel Company Blending Problem	229
10.2.2 Formulation and Solution of the Pittsburgh Steel Blending Problem.....	230
10.3 A Blending Problem within a Product Mix Problem	232
10.3.1 Formulation	233
10.3.2 Representing Two-sided Constraints.....	234
10.4 Proper Choice of Alternate Interpretations of Quality Requirements	237
10.5 How to Compute Blended Quality	239
10.5.1 Example	240
10.5.2 Generalized Mean.....	240
10.6 Interpretation of Dual Prices for Blending Constraints	242
10.7 Fractional or Hyperbolic Programming.....	242
10.8 Multi-Level Blending: Pooling Problems.....	243
10.9 Problems.....	248

11 Formulating and Solving Integer Programs	261
11.1 Introduction	261
11.1.1 Types of Variables	261
11.2 Exploiting the IP Capability: Standard Applications	262
11.2.1 Binary Representation of General Integer Variables	262
11.2.2 Minimum Batch Size Constraints	262
11.2.3 Fixed Charge Problems	263
11.2.4 The Simple Plant Location Problem	263
11.2.5 The Capacitated Plant Location Problem (CPL)	265
11.2.6 Modeling Alternatives with the Scenario Approach	267
11.2.7 Linearizing a Piecewise Linear Function	268
11.2.8 Converting to Separable Functions	271
11.3 Outline of Integer Programming Methods	272
11.4 Computational Difficulty of Integer Programs	274
11.4.1 NP-Complete Problems	275
11.5 Problems with Naturally Integer Solutions and the Prayer Algorithm	275
11.5.1 Network LPs Revisited	276
11.5.2 Integral Leontief Constraints	276
11.5.3 Example: A One-Period MRP Problem	277
11.5.4 Transformations to Naturally Integer Formulations	279
11.6 The Assignment Problem and Related Sequencing and Routing Problems	281
11.6.1 Example: The Assignment Problem	281
11.6.2 The Traveling Salesperson Problem	283
11.6.3 Capacitated Multiple TSP/Vehicle Routing Problems	289
11.6.4 Minimum Spanning Tree	293
11.6.5 The Linear Ordering Problem	293
11.6.6 Quadratic Assignment Problem	296
11.7 Problems of Grouping, Matching, Covering, Partitioning, and Packing	299
11.7.1 Formulation as an Assignment Problem	300
11.7.2 Matching Problems, Groups of Size Two	301
11.7.3 Groups with More Than Two Members	303
11.7.4 Groups with a Variable Number of Members, Assignment Version	307
11.7.5 Groups with A Variable Number of Members, Packing Version	308
11.7.6 Groups with A Variable Number of Members, Cutting Stock Problem	311
11.7.7 Groups with A Variable Number of Members, Vehicle Routing	315
11.8 Linearizing Products of Variables	320
11.8.1 Example: Bundling of Products	320
11.9 Representing Logical Conditions	323
11.10 Problems	324
12 Decision making Under Uncertainty and Stochastic Programs	335
12.1 Introduction	335
12.2 Identifying Sources of Uncertainty	335
12.3 The Scenario Approach	336
12.4 A More Complicated Two-Period Planning Problem	338
12.4.1 The Warm Winter Solution	340
12.4.2 The Cold Winter Solution	340

12.4.3 The Unconditional Solution	341
12.5 Expected Value of Perfect Information (EVPI)	344
12.6 Expected Value of Modeling Uncertainty	345
12.6.1 Certainty Equivalence	345
12.7 Risk Aversion.....	346
12.7.1 Downside Risk	347
12.7.2 Example	348
12.8 Choosing Scenarios	350
12.8.1 Matching Scenario Statistics to Targets	351
12.8.2 Generating Scenarios with a Specified Covariance Structure.....	352
12.8.3 Generating a Suitable Z Matrix	353
12.8.4 Example	354
12.8.5 Converting Multi-Stage Problems to Two-Stage Problems	355
12.9 Decisions Under Uncertainty with More than Two Periods	355
12.9.1 Dynamic Programming and Financial Option Models	356
12.9.2 Binomial Tree Models of Interest Rates.....	357
12.9.3 Binomial Tree Models of Foreign Exchange Rates	361
12.10 Decisions Under Uncertainty with an Infinite Number of Periods.....	363
12.10.1 Example: Cash Balance Management	365
12.11 Chance-Constrained Programs	368
12.12 Problems.....	369
13 Portfolio Optimization.....	371
13.1 Introduction	371
13.2 The Markowitz Mean/Variance Portfolio Model.....	371
13.2.1 Example	372
13.3 Dualing Objectives: Efficient Frontier and Parametric Analysis	375
13.3.1 Portfolios with a Risk-Free Asset.....	375
13.3.2 The Sharpe Ratio.....	378
13.4 Important Variations of the Portfolio Model	379
13.4.1 Portfolios with Transaction Costs	380
13.4.2 Example	380
13.4.3 Portfolios with Taxes.....	382
13.4.4 Factors Model for Simplifying the Covariance Structure	384
13.4.5 Example of the Factor Model.....	385
13.4.6 Scenario Model for Representing Uncertainty	386
13.4.7 Example: Scenario Model for Representing Uncertainty.....	387
13.5 Measures of Risk other than Variance	389
13.5.1 Maximizing the Minimum Return	390
13.5.2 Value at Risk.....	391
13.5.3 Example of VAR.....	392
13.6 Scenario Model and Minimizing Downside Risk.....	393
13.6.1 Semi-variance and Downside Risk	394
13.6.2 Downside Risk and MAD	396
13.6.3 Scenarios Based Directly Upon a Covariance Matrix.....	396
13.7 Hedging, Matching and Program Trading	398
13.7.1 Portfolio Hedging	398

13.7.2 Portfolio Matching, Tracking, and Program Trading	398
13.8 Methods for Constructing Benchmark Portfolios	399
13.8.1 Scenario Approach to Benchmark Portfolios	402
13.8.2 Efficient Benchmark Portfolios	404
13.8.3 Efficient Formulation of Portfolio Problems	405
13.9 Cholesky Factorization for Quadratic Programs	407
13.10 Problems	409
14 Multiple Criteria and Goal Programming	411
14.1 Introduction	411
14.1.1 Alternate Optima and Multicriteria	412
14.2 Approaches to Multi-criteria Problems	412
14.2.1 Pareto Optimal Solutions and Multiple Criteria	412
14.2.2 Utility Function Approach	412
14.2.3 Trade-off Curves	413
14.2.4 Example: Ad Lib Marketing	413
14.3 Goal Programming and Soft Constraints	416
14.3.1 Example: Secondary Criterion to Choose Among Alternate Optima	417
14.3.2 Preemptive/Lexico Goal Programming	419
14.4 Minimizing the Maximum Hurt, or Unordered Lexico Minimization	422
14.4.1 Example	423
14.4.2 Finding a Unique Solution Minimizing the Maximum	423
14.5 Identifying Points on the Efficient Frontier	428
14.5.1 Efficient Points, More-is-Better Case	428
14.5.2 Efficient Points, Less-is-Better Case	430
14.5.3 Efficient Points, the Mixed Case	432
14.6 Comparing Performance with Data Envelopment Analysis	433
14.7 Problems	438
15 Economic Equilibria and Pricing	441
15.1 What is an Equilibrium?	441
15.2 A Simple Simultaneous Price/Production Decision	442
15.3 Representing Supply & Demand Curves in LPs	443
15.4 Auctions as Economic Equilibria	447
15.5 Multi-Product Pricing Problems	451
15.6 General Equilibrium Models of An Economy	455
15.7 Transportation Equilibria	457
15.7.1 User Equilibrium vs. Social Optimum	461
15.8 Equilibria in Networks as Optimization Problems	463
15.8.1 Equilibrium Network Flows	465
15.9 Problems	467
16 Game Theory and Cost Allocation	471
16.1 Introduction	471
16.2 Two-Person Games	471
16.2.1 The Minimax Strategy	472
16.3 Two-Person Non-Constant Sum Games	474

16.3.1 Prisoner's Dilemma	475
16.3.2 Choosing a Strategy	476
16.3.3 Bimatrix Games with Several Solutions	479
16.4 Nonconstant-Sum Games Involving Two or More Players	481
16.4.1 Shapley Value	483
16.5 The Stable Marriage/Assignment Problem.....	483
16.5.1 The Stable Room-mate Matching Problem.....	487
16.6 Problems.....	490
17 Inventory, Production, and Supply Chain Management	493
17.1 Introduction	493
17.2 One Period News Vendor Problem	493
17.2.1 Analysis of the Decision.....	494
17.3 Multi-Stage News Vendor.....	496
17.3.1 Ordering with a Backup Option.....	499
17.3.2 Safety Lotsize	501
17.3.3 Multiproduct Inventories with Substitution	502
17.4 Economic Order Quantity	506
17.5 The Q,r Model.....	507
17.5.1 Distribution of Lead Time Demand	507
17.5.2 Cost Analysis of Q,r	507
17.6 Base Stock Inventory Policy	512
17.6.1 Base Stock — Periodic Review	513
17.6.2 Policy.....	513
17.6.3 Analysis.....	513
17.6.4 Base Stock — Continuous Review	515
17.7 Multi-Echelon Base Stock, the METRIC Model.....	515
17.8 DC With Holdback Inventory/Capacity	519
17.9 Multiproduct, Constrained Dynamic Lot Size Problems	521
17.9.1 Input Data.....	522
17.9.2 Example	523
17.9.3 Extensions.....	528
17.10 Problems.....	529
18 Design & Implementation of Service and Queuing Systems.....	531
18.1 Introduction	531
18.2 Forecasting Demand for Services	531
18.3 Waiting Line or Queuing Theory.....	532
18.3.1 Arrival Process	533
18.3.2 Queue Discipline.....	534
18.3.3 Service Process	534
18.3.4 Performance Measures for Service Systems	534
18.3.5 Stationarity	535
18.3.6 A Handy Little Formula	535
18.3.7 Example	535
18.4 Solved Queuing Models	536
18.4.1 Number of Outbound WATS lines via Erlang Loss Model.....	537

18.4.2 Evaluating Service Centralization via the Erlang C Model	538
18.4.3 A Mixed Service/Inventory System via the M/G/ ∞ Model	539
18.4.4 Optimal Number of Repairmen via the Finite Source Model	540
18.4.5 Selection of a Processor Type via the M/G/1 Model	541
18.4.6 Multiple Server Systems with General Distribution, M/G/c & G/G/c	543
18.5 Critical Assumptions and Their Validity	545
18.6 Networks of Queues	545
18.7 Designer Queues	547
18.7.1 Example: Positive but Finite Waiting Space System	547
18.7.2 Constant Service Time. Infinite Source. No Limit on Line Length	550
18.7.3 Example Effect of Service Time Distribution	550
18.8 Problems	553
19 Design & Implementation of Optimization-Based Decision Support Systems	555
19.1 General Structure of the Modeling Process	555
19.1.1 Developing the Model: Detail and Maintenance	556
19.2 Verification and Validation	556
19.2.1 Appropriate Level of Detail and Validation	556
19.2.2 When Your Model & the RW Disagree, Bet on the RW	557
19.2.3 Should We Behave Non-Optimally?	558
19.3 Separation of Data and System Structure	558
19.3.1 System Structure	559
19.4 Marketing the Model	559
19.4.1 Reports	559
19.4.2 Report Generation in LINGO	563
19.5 Reducing Model Size	565
19.5.1 Reduction by Aggregation	566
19.5.2 Reducing the Number of Nonzeroes	569
19.5.3 Reducing the Number of Nonzeroes in Covering Problems	569
19.6 On-the-Fly Column Generation	571
19.6.1 Example of Column Generation Applied to a Cutting Stock Problem	572
19.6.2 Column Generation and Integer Programming	576
19.6.3 Row Generation	576
19.7 Problems	577
References	579
INDEX	589

Preface

This book shows how to use the power of optimization, sometimes known as mathematical programming, to solve problems of business, industry, and government. The intended audience is students of business, managers, and engineers. The major technical skill required of the reader is to be comfortable with the idea of using a symbol to represent an unknown quantity.

This book is one of the most comprehensive expositions available on how to apply optimization models to important business and industrial problems. If you do not find your favorite business application explicitly listed in the table of contents, check the very comprehensive index at the back of the book.

There are essentially three kinds of chapters in the book:

1. introduction to modeling (chapters 1, 3, 4, and 19),
2. solving models with a computer (chapters 2, 5), and
3. application specific illustration of modeling with LINGO (chapters 6-18).

Readers completely new to optimization should read at least the first five chapters. Readers familiar with optimization, but unfamiliar with LINGO, should read at least chapters 2 and 5. Readers familiar with optimization and familiar with at least the concepts of a modeling language can probably skip to chapters 6-18. One can pick and choose from these chapters on applications. There is no strong sequential ordering among chapters 6-18, other than that the easier topics are in the earlier chapters. Among these application chapters, chapters 11 (on integer programming), and 12 (on stochastic programming) are worthy of special mention. They cover two computationally intensive techniques of fairly general applicability. As computers continue to grow more powerful, integer programming and stochastic programming will become even more valuable. Chapter 19 is a concluding chapter on implementing optimization models. It requires some familiarity with the details of models, as illustrated in the preceding chapters.

There is a natural progression of skills needed as technology develops. For optimization, it has been:

- 1) Ability to solve the models: 1950's
- 2) Ability to formulate optimization models: 1970's
- 3) Ability to use turnkey or template models: 1990's onward.

This book has no material on the mathematics of solving optimization models. For users who are discovering new applications, there is a substantial amount of material on the formulation of optimization models. For the modern "two minute" manager, there is a big collection of "off-the-shelf", ready-to-apply template models throughout the book.

Users familiar with the text *Optimization Modeling with LINDO* will notice much of the material in this current book is based on material in the LINDO book. The major differences are due to the two very important capabilities of LINGO: the ability to solve nonlinear models, and the availability of the set or vector notation for compactly representing large models.

Acknowledgments

This book has benefited from comments and corrections from Egon Balas, Robert Bosch, Angel G. Coca Balta, Sergio Chayet, Richard Darst, Daniel Davidson, Robert Dell, Hamilton Emmons, Saul Gass, Tom Knowles, Milt Gutterman, Changpyo David Hong, Kipp Martin, Syam Menon, Raul

Negro, David Phillips, J. Pye, Fritz Raffensperger, Rick Rosenthal, James Schmidt, Paul Schweitzer, Shuichi Shinmura, Rob Stubbs, David Tulett, Richard Wendell, Mark Wiley, and Gene Woolsey and his students. The outstanding software expertise and sage advice of Kevin Cunningham was crucial. The production of this book (from editing and formatting to printing) was ably managed by Sarah Snider, Hanzade Izmit, Srinath Tumu and Jane Rees.

What Is Optimization?

1.1 Introduction

Optimization, or constrained optimization, or mathematical programming, is a mathematical procedure for determining optimal allocation of scarce resources. Optimization, and its most popular special form, Linear Programming (LP), has found practical application in almost all facets of business, from advertising to production planning. Transportation and aggregate production planning problems are the most typical objects of LP analysis. The petroleum industry was an early intensive user of LP for solving fuel blending problems.

It is important for the reader to appreciate at the outset that the “programming” in Mathematical Programming is of a different flavor than the “programming” in Computer Programming. In the former case, it means to plan and organize (as in “Get with the program!”). In the latter case, it means to write instructions for performing calculations. Although aptitude in one suggests aptitude in the other, training in the one kind of programming has very little direct relevance to the other.

For most optimization problems, one can think of there being *two important classes of objects*. The first of these is *limited resources*, such as land, plant capacity, and sales force size. The second is *activities*, such as “produce low carbon steel,” “produce stainless steel,” and “produce high carbon steel.” *Each activity consumes* or possibly *contributes* additional amounts of the *resources*. The problem is to determine the best combination of activity levels that does not use more resources than are actually available. We can best gain the flavor of LP by using a simple example.

1.2 A Simple Product Mix Problem

The Enginola Television Company produces two types of TV sets, the “Astro” and the “Cosmo”. There are two production lines, one for each set. The Astro production line has a capacity of 60 sets per day, whereas the capacity for the Cosmo production line is only 50 sets per day. The labor requirements for the Astro set is 1 person-hour, whereas the Cosmo requires a full 2 person-hours of labor. Presently, there is a maximum of 120 man-hours of labor per day that can be assigned to production of the two types of sets. If the profit contributions are \$20 and \$30 for each Astro and Cosmo set, respectively, what should be the daily production?

2 Chapter 1 What is Optimization?

A structured, but verbal, description of what we want to do is:

Maximize Profit contribution
subject to Astro production less-than-or-equal-to Astro capacity,
Cosmo production less-than-or-equal-to Cosmo capacity,
Labor used less-than-or-equal-to labor availability.

Until there is a significant improvement in artificial intelligence/expert system software, we will need to be more precise if we wish to get some help in solving our problem. We can be more precise if we define:

A = units of Astros to be produced per day,
 C = units of Cosmos to be produced per day.

Further, we decide to measure:

Profit contribution in dollars,
Astro usage in units of Astros produced,
Cosmo usage in units of Cosmos produced, and
Labor in person-hours.

Then, a precise statement of our problem is:

Maximize $20A + 30C$ (Dollars)
subject to $A \leq 60$ (Astro capacity)
 $C \leq 50$ (Cosmo capacity)
 $A + 2C \leq 120$ (Labor in person-hours)

The first line, “Maximize $20A+30C$ ”, is known as the *objective function*. The remaining three lines are known as *constraints*. Most optimization programs, sometimes called “solvers”, assume all variables are constrained to be nonnegative, so stating the constraints $A \geq 0$ and $C \geq 0$ is unnecessary.

Using the terminology of resources and activities, there are three resources: Astro capacity, Cosmo capacity, and labor capacity. The activities are Astro and Cosmo production. It is generally true that, with each constraint in an optimization model, one can associate some resource. For each decision variable, there is frequently a corresponding physical activity.

1.2.1 Graphical Analysis

The Enginola problem is represented graphically in Figure 1.1. The feasible production combinations are the points in the lower left enclosed by the five solid lines. We want to find the point in the feasible region that gives the highest profit.

To gain some idea of where the maximum profit point lies, let’s consider some possibilities. The point $A = C = 0$ is feasible, but it does not help us out much with respect to profits. If we spoke with the manager of the Cosmo line, the response might be: “The Cosmo is our more profitable product. Therefore, we should make as many of it as possible, namely 50, and be satisfied with the profit contribution of $30 \times 50 = \$1500$.”

Figure 1.1 Feasible Region for Enginola

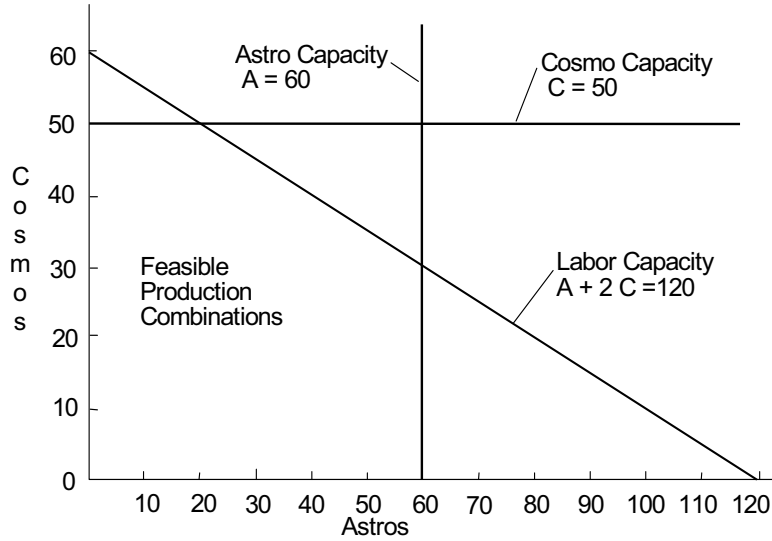

You, the thoughtful reader, might observe there are many combinations of A and C , other than just $A = 0$ and $C = 50$, that achieve \$1500 of profit. Indeed, if you plot the line $20A + 30C = 1500$ and add it to the graph, then you get Figure 1.2. Any point on the dotted line segment achieves a profit of \$1500. Any line of constant profit such as that is called an iso-profit line (or iso-cost in the case of a cost minimization problem).

If we next talk with the manager of the Astro line, the response might be: “If you produce 50 Cosmos, you still have enough labor to produce 20 Astros. This would give a profit of $30 \times 50 + 20 \times 20 = \1900 . That is certainly a respectable profit. Why don’t we call it a day and go home?”

Figure 1.2 Enginola With "Profit = 1500"

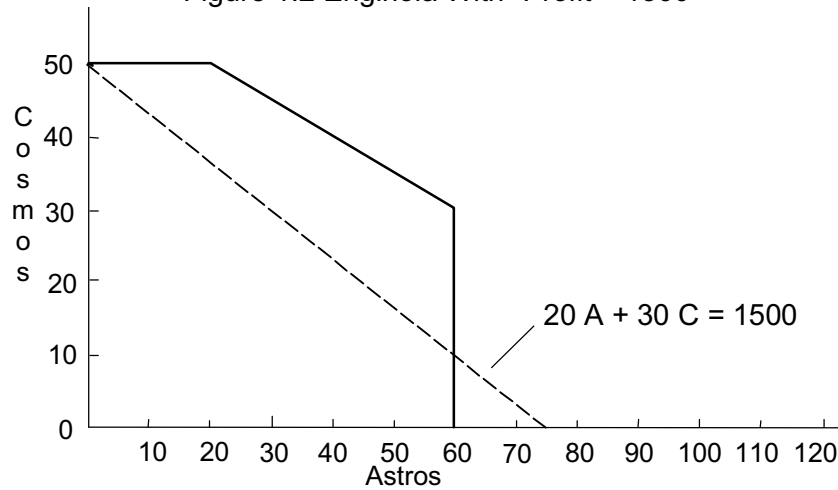

4 Chapter 1 What is Optimization?

Our ever-alert reader might again observe that there are many ways of making \$1900 of profit. If you plot the line $20A + 30C = 1900$ and add it to the graph, then you get Figure 1.3. Any point on the higher rightmost dotted line segment achieves a profit of \$1900.

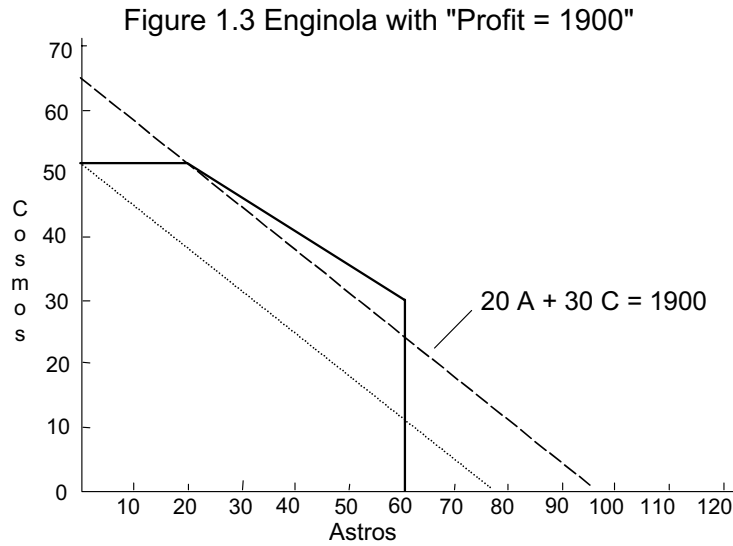

Now, our ever-perceptive reader makes a leap of insight. As we increase our profit aspirations, the dotted line representing all points that achieve a given profit simply shifts in a parallel fashion. Why not shift it as far as possible for as long as the line contains a feasible point? This last and best feasible point is $A = 60$, $C = 30$. It lies on the line $20A + 30C = 2100$. This is illustrated in Figure 1.4. Notice, even though the profit contribution per unit is higher for Cosmo, we did not make as many (30) as we feasibly could have made (50). Intuitively, this is an optimal solution and, in fact, it is. The graphical analysis of this small problem helps understand what is going on when we analyze larger problems.

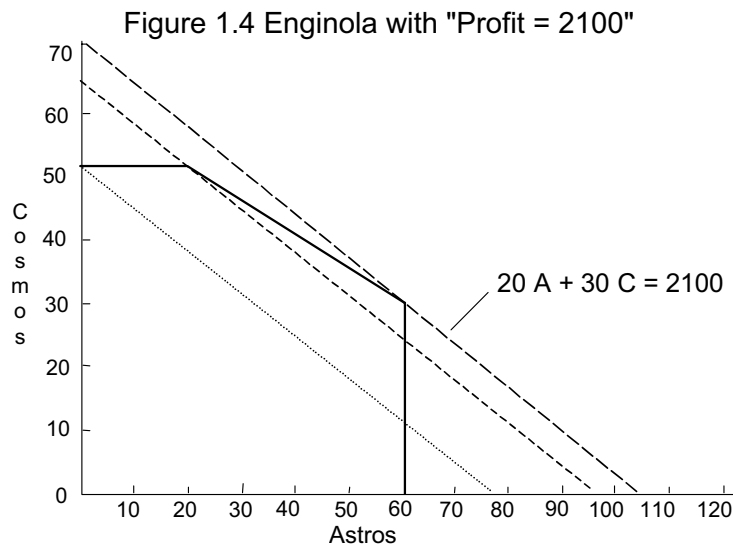

1.3 Linearity

We have now seen one example. We will return to it regularly. This is an example of a linear mathematical program, or LP for short. Solving linear programs tends to be substantially easier than solving more general mathematical programs. Therefore, it is worthwhile to dwell for a bit on the linearity feature.

Linear programming applies *directly* only to situations in which the effects of the different activities in which we can engage are linear. For practical purposes, we can think of the linearity requirement as consisting of three features:

1. *Proportionality*. The effects of a single variable or activity by itself are proportional (e.g., doubling the amount of steel purchased will double the dollar cost of steel purchased).
2. *Additivity*. The interactions among variables must be additive (e.g., the dollar amount of sales is the sum of the steel dollar sales, the aluminum dollar sales, etc.; whereas the amount of electricity used is the sum of that used to produce steel, aluminum, etc).
3. *Continuity*. The variables must be continuous (i.e., fractional values for the decision variables, such as 6.38, must be allowed). If both 2 and 3 are feasible values for a variable, then so is 2.51.

A model that includes the two decision variables “price per unit sold” and “quantity of units sold” is probably not linear. The proportionality requirement is satisfied. However, the interaction between the two decision variables is multiplicative rather than additive (i.e., $dollar\ sales = price \times quantity$, not $price + quantity$).

If a supplier gives you quantity discounts on your purchases, then the cost of purchases will not satisfy the proportionality requirement (e.g., the total cost of the stainless steel purchased may be less than proportional to the amount purchased).

A model that includes the decision variable “number of floors to build” might satisfy the proportionality and additivity requirements, but violate the continuity conditions. The recommendation to build 6.38 floors might be difficult to implement unless one had a designer who was ingenious with split level designs. Nevertheless, the solution of an LP might recommend such fractional answers.

The possible formulations to which LP is applicable are substantially more general than that suggested by the example. The objective function may be minimized rather than maximized; the direction of the constraints may be \geq rather than \leq , or even $=$; and any or all of the parameters (e.g., the 20, 30, 60, 50, 120, 2, or 1) may be negative instead of positive. The principal restriction on the class of problems that can be analyzed results from the linearity restriction.

Fortunately, as we will see later in the chapters on integer programming and quadratic programming, there are other ways of accommodating these violations of linearity.

Figure 1.5 illustrates some nonlinear functions. For example, the expression $X \times Y$ satisfies the proportionality requirement, but the effects of X and Y are not additive. In the expression $X^2 + Y^2$, the effects of X and Y are additive, but the effects of each individual variable are not proportional.

Figure 1.5: Nonlinear Relations

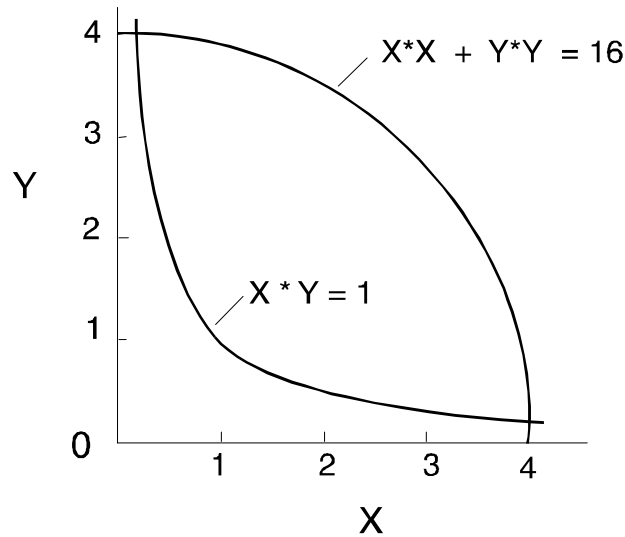

1.4 Analysis of LP Solutions

When you direct the computer to solve a math program, the possible outcomes are indicated in Figure 1.6.

For a properly formulated LP, the leftmost path will be taken. The solution procedure will first attempt to find a feasible solution (i.e., a solution that simultaneously satisfies all constraints, but does not necessarily maximize the objective function). The rightmost, “No Feasible Solution”, path will be taken if the formulator has been too demanding. That is, two or more constraints are specified that cannot be simultaneously satisfied. A simple example is the pair of constraints $x \leq 2$ and $x \geq 3$. The nonexistence of a feasible solution does not depend upon the objective function. It depends solely upon the constraints. In practice, the “No Feasible Solution” outcome might occur in a large complicated problem in which an upper limit was specified on the number of productive hours available and an unrealistically high demand was placed on the number of units to be produced. An alternative message to “No Feasible Solution” is “You Can’t Have Your Cake and Eat It Too”.

Figure 1.6 Solution Outcomes

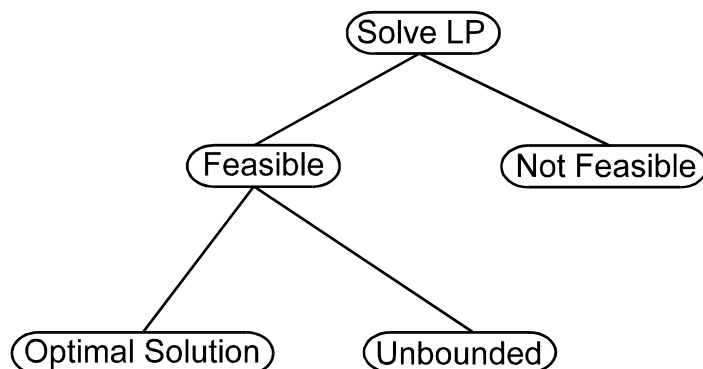

If a feasible solution has been found, then the procedure attempts to find an optimal solution. If the “Unbounded Solution” termination occurs, it implies the formulation admits the unrealistic result that an infinite amount of profit can be made. A more realistic conclusion is that an important constraint has been omitted or the formulation contains a critical typographical error.

We can solve the Enginola problem in LINGO by typing the following:

```

MODEL:
  MAX = 20*A + 30*C;
  A <= 60;
  C <= 50;
  A + 2*C <= 120;
END
  
```

We can solve the problem in the Windows version of LINGO by clicking on the red “bullseye” icon. We can get the following solution report by clicking on the “X=” icon”:

```

Objective value: 2100.000
Variable      Value      Reduced Cost
  A          60.00000      0.00000
  C          30.00000      0.00000
Row   Slack or Surplus   Dual Price
  1     2100.00000       1.00000
  2         0.00000       5.00000
  3     20.00000        0.00000
  4         0.00000      15.00000
  
```

The output has three sections, an informative section, a “variables” section, and a “rows” section. The second two sections are straightforward. The maximum profit solution is to produce 60 Astros and 30 Cosmos for a profit contribution of \$2,100. This solution will leave zero slack in row 2 (the constraint $A \leq 60$), a slack of 20 in row 3 (the constraint $C \leq 50$), and no slack in row 4 (the constraint $A + 2C \leq 120$). Note $60 + 2 \times 30 = 120$.

The third column contains a number of opportunity or marginal cost figures. These are useful by-products of the computations. The interpretation of these “reduced costs” and “dual prices” is discussed in the next section. The reduced cost/dual price section is optional and can be turned on or off by clicking on LINGO | Options | General Solver | Dual Computations | Prices.

1.5 Sensitivity Analysis, Reduced Costs, and Dual Prices

Realistic LPs require large amounts of data. Accurate data are expensive to collect, so we will generally be forced to use data in which we have less than complete confidence. A time-honored adage in data processing circles is “garbage in, garbage out”. A user of a model should be concerned with how the recommendations of the model are altered by changes in the input data. Sensitivity analysis is the term applied to the process of answering this question. Fortunately, an LP solution report provides supplemental information that is useful in sensitivity analysis. This information falls under two headings, reduced costs and dual prices.

Sensitivity analysis can reveal which pieces of information should be estimated most carefully. For example, if it is blatantly obvious that a certain product is unprofitable, then little effort need be expended in accurately estimating its costs. The first law of modeling is “do not waste time accurately estimating a parameter if a modest error in the parameter has little effect on the recommended decision”.

1.5.1 Reduced Costs

Associated with each variable in any solution is a quantity known as the *reduced cost*. If the units of the objective function are dollars and the units of the variable are gallons, then the units of the reduced cost are dollars per gallon. The reduced cost of a variable is the amount by which the profit contribution of the variable must be improved (e.g., by reducing its cost) before the variable in question would have a positive value in an optimal solution. Obviously, a variable that already appears in the optimal solution will have a zero reduced cost.

It follows that a second, correct interpretation of the reduced cost is that it is the rate at which the objective function value will deteriorate if a variable, currently at zero, is arbitrarily forced to increase a small amount. Suppose the reduced cost of x is \$2/gallon. This means, if the profitability of x were increased by \$2/gallon, then 1 unit of x (if 1 unit is a “small change”) could be brought into the solution without affecting the total profit. Clearly, the total profit would be reduced by \$2 if x were increased by 1.0 without altering its original profit contribution.

1.5.2 Dual Prices

Associated with each constraint is a quantity known as the *dual price*. If the units of the objective function are cruzeiros and the units of the constraint in question are kilograms, then the units of the dual price are cruzeiros per kilogram. The dual price of a constraint is the rate at which the objective function value will improve as the right-hand side or constant term of the constraint is increased a small amount.

Different optimization programs may use different sign conventions with regard to the dual prices. The LINGO computer program uses the convention that a positive dual price means increasing the right-hand side in question will improve the objective function value. On the other hand, a negative dual price means an increase in the right-hand side will cause the objective function value to deteriorate. A zero dual price means changing the right-hand side a small amount will have no effect on the solution value.

It follows that, under this convention, \leq constraints will have nonnegative dual prices, \geq constraints will have nonpositive dual prices, and $=$ constraints can have dual prices of any sign. Why?

Understanding Dual Prices. It is instructive to analyze the dual prices in the solution to the Enginola problem. The dual price on the constraint $A \leq 60$ is \$5/unit. At first, one might suspect this quantity should be \$20/unit because, if one more Astro is produced, the simple profit contribution of

this unit is \$20. An additional Astro unit will require sacrifices elsewhere, however. Since all of the labor supply is being used, producing more Astros would require the production of Cosmos to be reduced in order to free up labor. The labor tradeoff rate for Astros and Cosmos is $\frac{1}{2}$. That is, producing one more Astro implies reducing Cosmo production by $\frac{1}{2}$ of a unit. The net increase in profits is $\$20 - (1/2) * \$30 = \$5$, because Cosmos have a profit contribution of \$30 per unit.

Now, consider the dual price of \$15/hour on the labor constraint. If we have 1 more hour of labor, it will be used solely to produce more Cosmos. One Cosmo has a profit contribution of \$30/unit. Since 1 hour of labor is only sufficient for one half of a Cosmo, the value of the additional hour of labor is \$15.

1.6 Unbounded Formulations

If we forget to include the labor constraint and the constraint on the production of Cosmos, then an unlimited amount of profit is possible by producing a large number of Cosmos. This is illustrated here:

$$\begin{aligned} \text{MAX} &= 20 * A + 30 * C; \\ A &\leq 60; \end{aligned}$$

This generates an error window with the message:

UNBOUNDED SOLUTION

There is nothing to prevent C from being infinitely large. The feasible region is illustrated in Figure 1.7. In larger problems, there are typically several unbounded variables and it is not as easy to identify the manner in which the unboundedness arises.

Figure 1.7 Graph of Unbounded Formulation

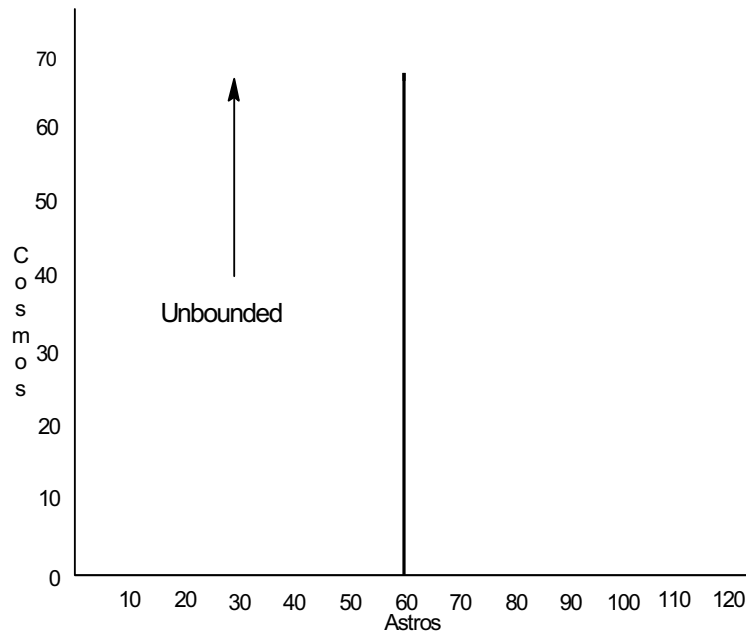

1.7 Infeasible Formulations

An example of an infeasible formulation is obtained if the right-hand side of the labor constraint is made 190 and its direction is inadvertently reversed. In this case, the most labor that can be used is to produce 60 Astros and 50 Cosmos for a total labor consumption of $60 + 2 \times 50 = 160$ hours. The formulation and attempted solution are:

```

MAX = (20 * A) + (30 * C);
A <= 60;
C <= 50;
A + 2 * C >= 190;

```

A window with the error message:

```
NO FEASIBLE SOLUTION.
```

will print. The reports window will generate the following:

Variable	Value	Reduced Cost
A	60.00000	0.0000000
C	50.00000	0.0000000
Row	Slack or Surplus	Dual Price
1	2700.000	0.0000000
2	0.0000000	1.0000000
3	0.0000000	2.0000000
4	-30.00000	-1.0000000

This “solution” is infeasible for the labor constraint by the amount of 30 person-hours ($190 - (1 \times 60 + 2 \times 50)$). The dual prices in this case give information helpful in determining how the infeasibility arose. For example, the +1 associated with row 2 indicates that increasing its right-hand side by one will decrease the infeasibility by 1. The +2 with row 3 means, if we allowed 1 more unit of Cosmo production, the infeasibility would decrease by 2 units because each Cosmo uses 2 hours of labor. The -1 associated with row 4 means that decreasing the right-hand side of the labor constraint by 1 would reduce the infeasibility by 1.

Figure 1.8 illustrates the constraints for this formulation.

Figure 1.8 Graph of Infeasible Formulation

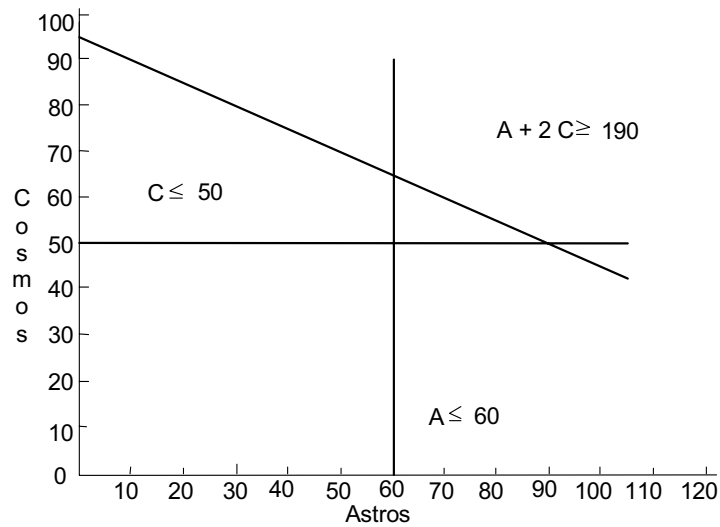

1.8 Multiple Optimal Solutions and Degeneracy

For a given formulation that has a bounded optimal solution, there will be a unique optimum objective function value. However, there may be several different combinations of decision variable values (and associated dual prices) that produce this unique optimal value. Such solutions are said to be degenerate in some sense. In the Enginola problem, for example, suppose the profit contribution of *A* happened to be \$15 rather than \$20. The problem and a solution are:

```

MAX = 15 * A + 30 * C;
A <= 60;
C <= 50;
A + 2 * C <= 120;
Optimal solution found at step:          1
Objective value:                      1800.000
Variable      Value      Reduced Cost
A              20.00000      0.0000000
C              50.00000      0.0000000
Row   Slack or Surplus      Dual Price
1     1800.000              1.000000
2     40.00000              0.000000
3     0.0000000             0.000000
4     0.0000000             15.00000
    
```

Figure 1.9 Model with Alternative Optima

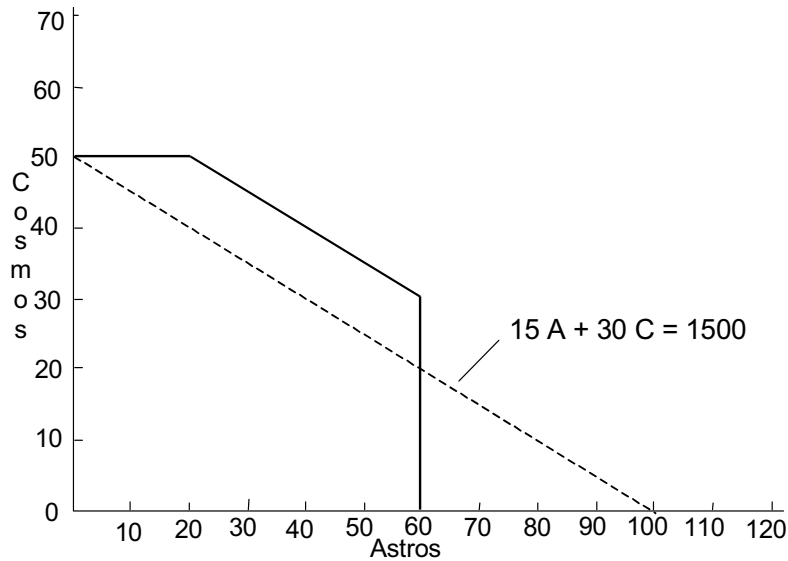

The feasible region, as well as a “profit = 1500” line, are shown in Figure 1.9. Notice the lines $A + 2C = 120$ and $15A + 30C = 1500$ are parallel. It should be apparent that any feasible point on the line $A + 2C = 120$ is optimal.

The particularly observant may have noted in the solution report that the constraint, $C \leq 50$ (i.e., row 3), has both zero slack and a zero dual price. This suggests the production of Cosmos could be decreased a small amount without any effect on total profits. Of course, there would have to be a compensatory increase in the production of Astros. We conclude that there must be an alternate optimum solution that produces more Astros, but fewer Cosmos. We can discover this solution by increasing the profitability of Astros ever so slightly. Observe:

```

MAX = 15.0001 * A + 30 * C;
A <= 60;
C <= 50;
A + 2 * C <= 120;

Optimal solution found at step:          1
Objective value:                      1800.006

Variable          Value          Reduced Cost
   A             60.00000          0.0000000
   C             30.00000          0.0000000

Row  Slack or Surplus          Dual Price
   1             1800.006          1.00000
   2             0.0000000          0.1000000E-03
   3             20.00000          0.0000000
   4             0.0000000          15.00000

```

As predicted, the profit is still about \$1800. However, the production of Cosmos has been decreased to 30 from 50, whereas there has been an increase in the production of Astros to 60 from 20.

1.8.1 The “Snake Eyes” Condition

Alternate optima may exist only if some row in the solution report has zeroes in both the second and third columns of the report, a configuration that some applied statisticians call “snake eyes”. That is, alternate optima may exist only if some variable has both zero value and zero reduced cost, or some constraint has both zero slack and zero dual price. Mathematicians, with no intent of moral judgment, refer to such solutions as degenerate.

If there are alternate optima, you may find your computer gives a different solution from that in the text. However, you should always get the same objective function value.

There are, in fact, two ways in which multiple optimal solutions can occur. For the example in Figure 1.9, the two optimal solution reports differ only in the values of the so-called primal variables (i.e., our original decision variables A , C) and the slack variables in the constraint. There can also be situations where there are multiple optimal solutions in which only the dual variables differ. Consider this variation of the Enginola problem in which the capacity of the Cosmo line has been reduced to 30.

The formulation is:

```

MAX = 20 * A + 30 * C;
A < 60;
!note that < and <= are equivalent;
!in LINGO;
C < 30;
A + 2 * C < 120;

```

The corresponding graph of this problem appears in Figure 1.10. An optimal solution is:

Optimal solution found at step:		0
Objective value:		2100.000
Variable	Value	Reduced Cost
A	60.00000	0.000000
C	30.00000	0.000000
Row	Slack or Surplus	Dual Price
1	2100.000	1.000000
2	0.000000	20.00000
3	0.000000	30.00000
4	0.000000	0.000000

Again, notice the “snake eyes” in the solution (i.e., the pair of zeroes in a row of the solution report). This suggests the capacity of the Cosmo line (the RHS of row 3) could be changed without changing the objective value. Figure 1.10 illustrates the situation. Three constraints pass through the point $A=60$, $C=30$. Any two of the constraints determine the point. In fact, the constraint $A+2C \leq 120$ is mathematically redundant (i.e., it could be dropped without changing the feasible region).

Figure 1.10 Alternate Solutions in Dual Variables

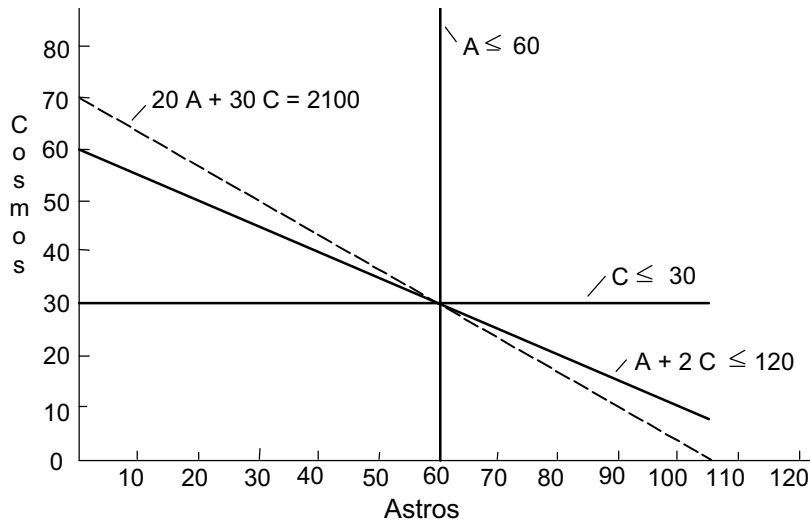

If you decrease the RHS of row 3 very slightly, you will get essentially the following solution:

Optimal solution found at step:		0
Objective value:		2100.000
Variable	Value	Reduced Cost
A	60.00000	0.0000000
C	30.00000	0.0000000
Row	Slack or Surplus	Dual Price
1	2100.000	1.0000000
2	0.0000000	5.0000000
3	0.0000000	0.0000000
4	0.0000000	15.0000000

Notice this solution differs from the previous one only in the dual values.

We can now state the following rule: If a solution report has the “snake eyes” feature (i.e., a pair of zeroes in any row of the report), then there may be an alternate optimal solution that differs either in the primal variables, the dual variables, or in both. If all the constraints are inequality constraints, then “snake eyes”, in fact, implies there is an alternate optimal solution. If one or more constraints are equality constraints, however, then the following example illustrates that “snake eyes” does not imply there has to be an alternate optimal solution:

```

MAX = 20 * A;
A <= 60;
C = 30;
    
```

The only solution is:

Optimal solution found at step:		0
Objective value:		1200.000
Variable	Value	Reduced Cost
A	60.000000	0.0000000
C	30.000000	0.0000000
Row	Slack or Surplus	Dual Price
1	1200.000	1.000000
2	0.0000000	20.00000
3	0.0000000	0.0000000

If a solution report exhibits the “snake eyes” configuration, a natural question to ask is: can we determine from the solution report alone whether the alternate optima are in the primal variables or the dual variables? The answer is “no”, as the following two related problems illustrate.

Problem D			Problem P		
MAX = X +	Y;		MAX = X + Y;		
X +	Y + Z <= 1;		X + Y +	Z <= 1;	
X + 2 * Y	<= 1;		X +	2 * Z <= 1;	

Both problems possess multiple optimal solutions. The ones that can be identified by the standard simplex solution methods are:

Solution 1

Problem D			Problem P		
OBJECTIVE VALUE			OBJECTIVE VALUE		
1)	1.00000000		1)	1.00000000	
Variable	Value	Reduced Cost	Variable	Value	Reduced Cost
X	1.000000	0.000000	X	1.000000	0.000000
Y	0.000000	0.000000	Y	0.000000	0.000000
Z	0.000000	1.000000	Z	0.000000	1.000000
Row	Slack or Surplus	Dual Prices	Row	Slack or Surplus	Dual Prices
2)	0.000000	1.000000	2)	0.000000	1.000000
3)	0.000000	0.000000	3)	0.000000	0.000000

Solution 2

Problem D			Problem P		
OBJECTIVE VALUE			OBJECTIVE VALUE		
1)	1.00000000		1)	1.00000000	
Variable	Value	Reduced Cost	Variable	Value	Reduced Cost
X	1.000000	0.000000	X	0.000000	0.000000
Y	0.000000	1.000000	Y	1.000000	0.000000
Z	0.000000	0.000000	Z	0.000000	1.000000
Row	Slack or Surplus	Dual Prices	Row	Slack or Surplus	Dual Prices
2)	0.000000	0.000000	2)	0.000000	1.000000
3)	0.000000	1.000000	3)	1.000000	0.000000

Notice that:

- *Solution 1* is exactly the same for both problems;
- *Problem D* has multiple optimal solutions in the dual variables (only); while
- *Problem P* has multiple optimal solutions in the primal variables (only).

Thus, one cannot determine from the solution report alone the kind of alternate optima that might exist. You can generate *Solution 1* by setting the RHS of row 3 and the coefficient of X in the objective to slightly larger than 1 (e.g., 1.001). Likewise, *Solution 2* is generated by setting the RHS of row 3 and the coefficient of X in the objective to slightly less than 1 (e.g., 0.9999).

Some authors refer to a problem that has multiple solutions to the primal variables as *dual degenerate* and a problem with multiple solutions in the dual variables as *primal degenerate*. Other authors say a problem has multiple optima only if there are multiple optimal solutions for the primal variables.

1.8.2 Degeneracy and Redundant Constraints

In small examples, degeneracy usually means there are redundant constraints. In general, however, especially in large problems, degeneracy does not imply there are redundant constraints. The constraint set below and the corresponding Figure 1.11 illustrate:

$$\begin{aligned} 2x - y &\leq 1 \\ 2x - z &\leq 1 \\ 2y - x &\leq 1 \\ 2y - z &\leq 1 \\ 2z - x &\leq 1 \\ 2z - y &\leq 1 \end{aligned}$$

Figure 1.11 Degeneracy but No Redundancy

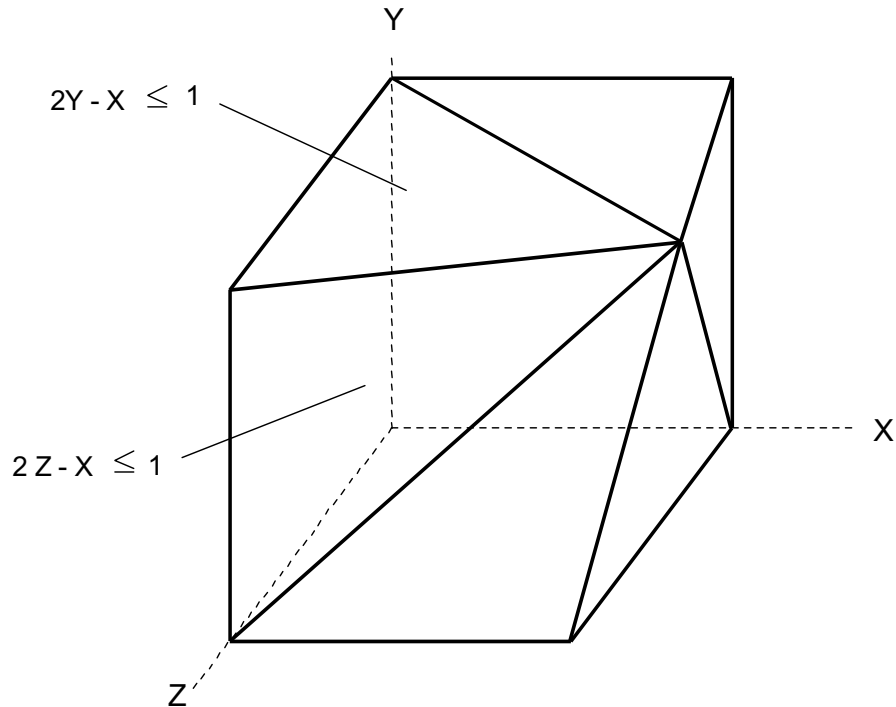

These constraints define a cone with apex or point at $x=y=z=1$, having six sides. The point $x=y=z=1$ is degenerate because it has more than three constraints passing through it. Nevertheless, none of the constraints are redundant. Notice the point $x=0.6, y=0, z=0.5$ violates the first constraint, but satisfies all the others. Therefore, the first constraint is nonredundant. By trying all six permutations of 0.6, 0, 0.5, you can verify each of the six constraints are nonredundant.

1.9 Nonlinear Models and Global Optimization

Throughout this text the emphasis is on formulating linear programs. Historically nonlinear models were to be avoided, if possible, for two reasons: a) they take much longer to solve, and b) once “solved” traditional solvers could only guarantee that you had a locally optimal solution. A solution is a local optimum if there is no better solution nearby, although there might be a much better solution some distance away. Traditional nonlinear solvers are like myopic mountain climbers, they can get you to the top of the nearest peak, but they may not see and get you to the highest peak in the mountain range. Versions of LINGO from LINGO 8 onward have a global solver option. If you check the global solver option, then you are guaranteed to get a global optimum, if you let the solver run long enough. To illustrate, suppose our problem is:

$$\begin{aligned} \text{Min} &= @\sin(x) + .5*@\text{abs}(x-9.5); \\ x &\leq 12; \end{aligned}$$

The graph of the function appears in Figure 1.12.

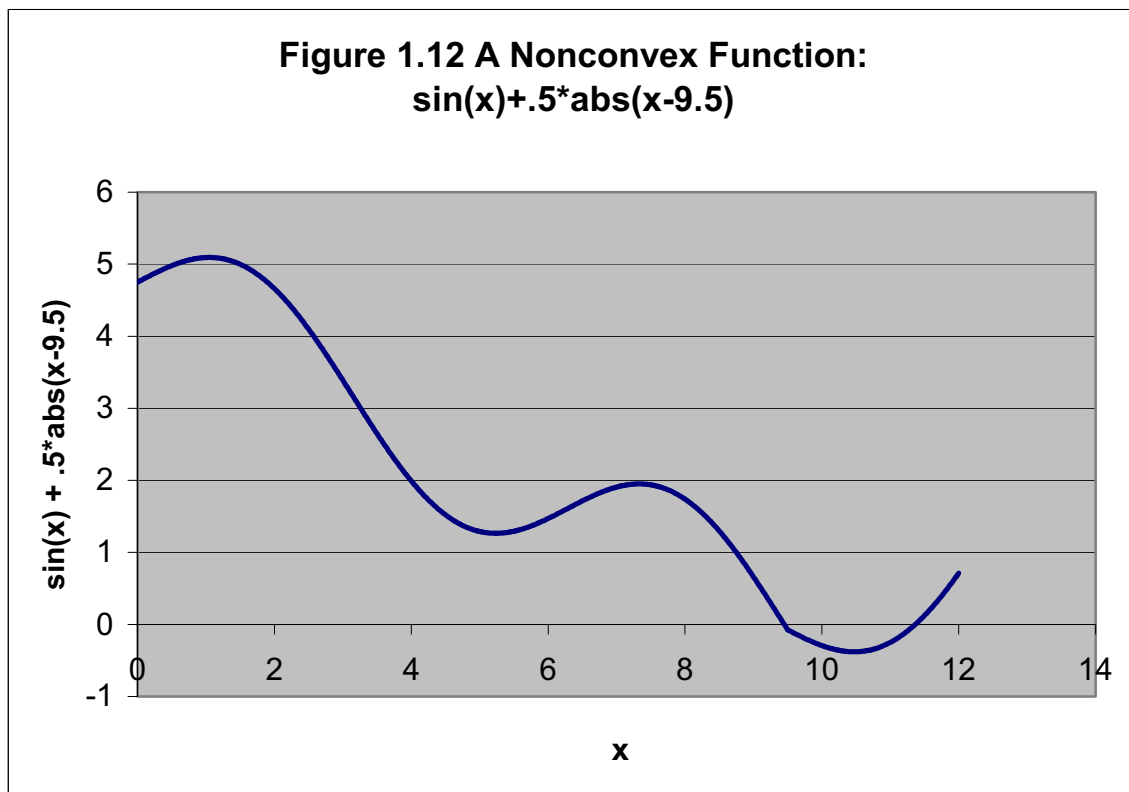

If you apply a traditional nonlinear solver to this model you might get one of three solutions: either $x = 0$, or $x = 5.235987$, or $x = 10.47197$. If you check the Global solver option in LINGO, it will report the solution $x = 10.47197$ and label it as a global optimum. Be forewarned that the global solver does not eliminate drawback (a), namely, nonlinear models may take a long time to solve to guaranteed optimality. Nevertheless, the global solver may give a very good, even optimal, solution very quickly but then take a long time to prove that there is no other better solution.

1.10 Problems

1. Your firm produces two products, Thyristors (T) and Lozenges (L), that compete for the scarce resources of your distribution system. For the next planning period, your distribution system has available 6,000 person-hours. Proper distribution of each T requires 3 hours and each L requires 2 hours. The profit contributions per unit are 40 and 30 for T and L , respectively. Product line considerations dictate that at least 1 T must be sold for each 2 L 's.
 - (a) Draw the feasible region and draw the profit line that passes through the optimum point.
 - (b) By simple common sense arguments, what is the optimal solution?

2. Graph the following LP problem:

$$\begin{aligned} &\text{Minimize } 4X + 6Y \\ &\text{subject to } 5X + 2Y \geq 12 \\ &\quad 3X + 7Y \geq 13 \\ &\quad X \geq 0, Y \geq 0. \end{aligned}$$

In addition, plot the line $4X + 6Y = 18$ and indicate the optimum point.

3. The Volkswagen Company produces two products, the Bug and the SuperBug, which share production facilities. Raw materials costs are \$600 per car for the Bug and \$750 per car for the SuperBug. The Bug requires 4 hours in the foundry/forge area per car; whereas, the SuperBug, because it uses newer more advanced dies, requires only 2 hours in the foundry/forge. The Bug requires 2 hours per car in the assembly plant; whereas, the SuperBug, because it is a more complicated car, requires 3 hours per car in the assembly plant. The available daily capacities in the two areas are 160 hours in the foundry/forge and 180 hours in the assembly plant. Note, if there are multiple machines, the total hours available per day may be greater than 24. The selling price of the Bug at the factory door is \$4800. It is \$5250 for the SuperBug. It is safe to assume whatever number of cars are produced by this factory can be sold.
- Write the linear program formulation of this problem.
 - The above description implies the capacities of the two departments (foundry/forge and assembly) are sunk costs. Reformulate the LP under the conditions that each hour of foundry/forge time cost \$90; whereas, each hour of assembly time cost \$60. The capacities remain as before. Unused capacity has no charge.
4. The Keyesport Quarry has two different pits from which it obtains rock. The rock is run through a crusher to produce two products: concrete grade stone and road surface chat. Each ton of rock from the South pit converts into 0.75 tons of stone and 0.25 tons of chat when crushed. Rock from the North pit is of different quality. When it is crushed, it produces a “50-50” split of stone and chat. The Quarry has contracts for 60 tons of stone and 40 tons of chat this planning period. The cost per ton of extracting and crushing rock from the South pit is 1.6 times as costly as from the North pit.
- What are the decision variables in the problem?
 - There are two constraints for this problem. State them in words.
 - Graph the feasible region for this problem.
 - Draw an appropriate objective function line on the graph and indicate graphically and numerically the optimal solution.
 - Suppose all the information given in the problem description is accurate. What additional information might you wish to know before having confidence in this model?
5. A problem faced by railroads is of assembling engine sets for particular trains. There are three important characteristics associated with each engine type, namely, operating cost per hour, horsepower, and tractive power. Associated with each train (e.g., the Super Chief run from Chicago to Los Angeles) is a required horsepower and a required tractive power. The horsepower required depends largely upon the speed required by the run; whereas, the tractive power required depends largely upon the weight of the train and the steepness of the grades encountered on the run. For a particular train, the problem is to find that combination of engines that satisfies the horsepower and tractive power requirements at lowest cost.

In particular, consider the Cimarron Special, the train that runs from Omaha to Santa Fe. This train requires 12,000 horsepower and 50,000 tractive power units. Two engine types, the GM-I and the GM-II, are available for pulling this train. The GM-I has 2,000 horsepower, 10,000 tractive power units, and its variable operating costs are \$150 per hour. The GM-II has 3,000 horsepower, 10,000 tractive power units, and its variable operating costs are \$180 per hour. The engine set may be mixed (e.g., use two GM-I's and three GM-II's).

Write the linear program formulation of this problem.

6. Graph the constraint lines and the objective function line passing through the optimum point and indicate the feasible region for the Enginola problem when:
 - (a) All parameters are as given except labor supply is 70 rather than 120.
 - (b) All parameters are as given originally except the variable profit contribution of a Cosmo is \$40 instead of \$30.
7. Consider the problem:

$$\begin{array}{ll}
 \text{Minimize} & 4x_1 + 3x_2 \\
 \text{Subject to} & 2x_1 + x_2 \geq 10 \\
 & -3x_1 + 2x_2 \leq 6 \\
 & x_1 + x_2 \geq 6 \\
 & x_1 \geq 0, x_2 \geq 0
 \end{array}$$

Solve the problem graphically.

8. The surgical unit of a small hospital is becoming more concerned about finances. The hospital cannot control or set many of the important factors that determine its financial health. For example, the length of stay in the hospital for a given type of surgery is determined in large part by government regulation. The amount that can be charged for a given type of surgical procedure is controlled largely by the combination of the market and government regulation. Most of the hospital's surgical procedures are elective, so the hospital has considerable control over which patients and associated procedures are attracted and admitted to the hospital. The surgical unit has effectively two scarce resources, the hospital beds available to it (70 in a typical week), and the surgical suite hours available (165 hours in a typical week). Patients admitted to this surgical unit can be classified into the following three categories:

Patient Type	Days of Stay	Surgical Suite Hours Needed	Financial Contribution
A	3	2	\$240
B	5	1.5	\$225
C	6	3	\$425

For example, each type B patient admitted will use (i) 5 days of the $7 \times 70 = 490$ bed-days available each week, and (ii) 1.5 hours of the 165 surgical suite hours available each week. One doctor has argued that the surgical unit should try to admit more type A patients. Her argument is that, “in terms of \$/days of stay, type A is clearly the best, while in terms of \$/(surgical suite hour), it is not much worse than B and C .”

Suppose the surgical unit can in fact control the number of each type of patient admitted each week (i.e., they are decision variables). How many of each type should be admitted each week?

Can you formulate it as an LP?

2

Solving Math Programs with LINGO

2.1 Introduction

The process of solving a math program requires a large number of calculations and is, therefore, best performed by a computer program. The computer program we will use is called LINGO. The main purpose of LINGO is to allow a user to quickly input a model formulation, solve it, assess the correctness or appropriateness of the formulation based on the solution, quickly make minor modifications to the formulation, and repeat the process. LINGO features a wide range of commands, any of which may be invoked at any time. LINGO checks whether a particular command makes sense in a particular context.

LINGO is available in two versions:

- 1) a Windows-specific version, and
- 2) a generic, text-based version.

The text-based version runs under most popular operating systems, including Unix and Linux. For either version, additional information is available to the user under the Help menu item or Help command. The Windows commands are covered briefly here. After the commands section, we will show you how to enter and solve a simple model.

2.2 LINGO for Windows

When LINGO for Windows starts, it opens a blank window known as a *Model Window*. The Model Window is where you “do all your work”. Output in LINGO is displayed in a *Report Window*. LINGO can generate a number of reports pertaining to your model. The following is a list of all the commands that are available to you, mainly in the model window.

2.2.1 File Menu

NEW F2 

Use the *NEW* command from the *File* menu, press *F2*, or use the button to create a new Model window. In the Model window, you can enter your model.

OPEN Ctrl+O 

Use the *OPEN* command from the *File* menu, press *Ctrl+O*, or use the button to open an existing file, typically a model file.

SAVE Ctrl+S 

Use the *SAVE* command from the *File* menu, press *Ctrl+S*, or use the button to save the active (frontmost) window. You can save any window — Model, Report, or Command— in this way. If the window is a new Model window, a Report window, or the Command window, *SAVE* opens the *SAVE AS...* dialog.

SAVE AS... F5

Use the *SAVE AS...* command from the *File* menu or press *F5* to save the active (frontmost) window under the name you enter in the dialog box.

CLOSE F6

Use the *CLOSE* command from the *File* menu or press *F6* to close the active (frontmost) window. If the window is a new Model window or you have changed the file, you will be asked whether you want to save the changes.

PRINT F7 

Use the *PRINT* command from the *File* menu, use the button, or press *F7* to send the active (frontmost) window to your printer.

PRINT SETUP... F8

Use the *PRINT SETUP...* command from the *File* menu or press *F8* to select the printer to which you want output to go.

PRINT PREVIEW Shift +F8

Use the *PRINT PREVIEW* command from the *File* menu or press *Shift+F8* to display each page of the active (frontmost) window as it will appear when printed.

LOG OUTPUT... F9

Use the *LOG OUTPUT...* command from the *File* menu or press *F9* to send all subsequent screen activity, which would be sent to the Command Window, to a text file. The command opens a standard Windows file dialog from which you can name the log file and choose to echo output to the screen. You may also choose either to overwrite an existing file in the *Log Output...* dialog box or to append subsequent output to it.

Once you have selected a file to write to, a check will appear in the *File* menu before the *Log Output...* Command. To turn off *Log Output*, simply select the command again.

TAKE COMMANDS... F11

Use the *TAKE COMMANDS...* command from the *File* menu or press *F11* to “Take” a LINGO batch file with commands and model text for automated operation.

IMPORT LINDO FILE... F12

Use the *IMPORT LINDO FILE...* command from the *File* menu or press *F12* to open a file containing a LINDO model in LINDO TAKE format.

EXPORT FILE

Use the *MPS FORMAT...* or *MPI FORMAT...* sub-commands from the *File | Export File* command to write MPS or MPI format files, respectively. The MPS file format is an industry standard format developed by IBM and is useful for passing models from one solver or platform to another. The MPI file format is a special format developed by LINDO Systems for representing all classes of mathematical programs—linear, integer, and nonlinear.

LICENSE

Use the *LICENSE* command from the *File* menu to enter a new password for LINGO. Some versions of LINGO require the user to input a password. Think of the password as a “key” that unlocks the LINGO application. If you upgrade your copy of LINGO, you will need to enter a new password.

DATABASE USER INFO

Use the *DATABASE USER INFO* command from the *File* menu when linking models directly to databases through use of the *@ODBC()* function. Many times the database you link your model to will require a user id and/or password. To avoid having to enter your user id and password each time your model is run, you can input them once at the start of your session using this command.

EXIT F10

Use the *EXIT* command from the *File* menu or press *F10* to quit LINGO.

2.2.2 Edit Menu**UNDO Ctrl+Z**

Use the *UNDO* command from the *Edit* menu, or press *Ctrl+Z*, to undo the last action.

CUT Ctrl+X 

Use the *CUT* command from the *Edit* menu, click the button, or press *Ctrl+X* to clear the selected text and place it on the clipboard for pasting.

COPY Ctrl+C 

Use the *COPY* command from the *Edit* menu, click the button, or press *Ctrl+C* to copy the selected text to the clipboard for pasting.

PASTE Ctrl+V 

Use the *PASTE* command from the *Edit* menu, click the button, or press *Ctrl+V* to paste clipboard contents at the insertion point.

PASTE SPECIAL...

Use the *PASTE SPECIAL* command from the *Edit* menu to insert a selected item from the Windows clipboard into the active (frontmost) window at the cursor insertion point, allowing choice as to how the object is pasted.

SELECT ALL... Ctrl +A

Use the *SELECT ALL* command from the *Edit* menu or press *Ctrl+A* to select the entire contents of the active (frontmost) window.

FIND ... Ctrl+F 

Use the *FIND* command from the *Edit* menu or press *Ctrl+F* to search for a desired string of text in the active (frontmost) window.

FIND NEXT... Ctrl +N

Use the *FIND NEXT* command from the *Edit* menu or press *Ctrl+N* to find the next instance of the text most recently searched for using the *FIND* command in the active (frontmost) window.

REPLACE Ctrl +H

Use the *REPLACE* command from the *Edit* menu or press *Ctrl+H* to replace one string of text with another in the active (frontmost) window.

GO TO LINE... Ctrl+T 

Use the *GO TO LINE* command from the *Edit* menu, click on the button, or press *Ctrl+T* to enter a line number of the active window to which you want to go.

MATCH PARENTHESIS Ctrl+P 

Use the *MATCH PARENTHESIS* command from the *Edit* menu, click the button, or type *Ctrl+P* to find the close parenthesis that corresponds to the open parenthesis you have selected.

In addition to this command, there is one other way to find matching parentheses. LINGO will highlight matching parentheses in red when the *Match Paren* option is enabled under the *LINGO|Options* command (see below). By placing the cursor immediately after one of the parentheses of interest, you will notice that the color of the parenthesis changes from black to red. LINGO will simultaneously display the matching parenthesis in red. These parentheses will remain displayed in red until you move the cursor to another position.

PASTE FUNCTION

Use the *PASTE FUNCTION* command from the *Edit* menu to paste any of LINGO's built-in functions at the current insertion point. Choose the category of the LINGO function you want to paste, then select the function from the cascading menu. LINGO inserts place holders for arguments in the functions.

SELECT FONT... Ctrl +J

Use the *SELECT FONT* command from the *Edit* menu or press *Ctrl+J* to select a new font in which to display the currently selected text.

INSERT NEW OBJECT

Use the *INSERT NEW OBJECT* command from the *Edit* menu to embed an OLE object into the LINGO document.

LINKS

Use the *LINKS* command from the *Edit* menu to control the links to external objects in your document.

OBJECT PROPERTIES Alt+Enter

Use the *OBJECT PROPERTIES* command from the *Edit* menu or press *Alt+Enter* to specify the properties of a selected, embedded object

2.2.3 LINGO Menu**SOLVE Ctrl+U** 

Use the *SOLVE* command from the *LINGO* menu, click on the button, or press *Ctrl+U* to send the model currently in memory to the LINGO solver. If you have more than one model open, the frontmost (or active) window is the one in memory.

SOLUTION... Ctrl+W

Use the *SOLUTION* command from the *LINGO* menu, click the button, or press *Ctrl+W* to open the Solutions dialog box. Here you can specify the way you want a report of the solution currently in memory to appear. When you click OK, LINGO writes the report to a Report Window.

RANGE Ctrl+R

Use the *RANGE* command from the *LINGO* menu or press *Ctrl+R* to see a standard range report.

OPTIONS... Ctrl+I 

Use the *OPTIONS...* command from the *LINGO* menu, click the button, or press *Ctrl+I* to change a number of parameters that affect the configuration of the program.

GENERATE... Ctrl+G/Ctrl+Q

Use the *DISPLAY MODEL* and *DON'T DISPLAY MODEL* sub-commands from the *LINGO* | *Generate* command or press *Ctrl+G* or *Ctrl+Q*, respectively, to create an expanded version of the current model. The expanded model explicitly lists all the generated constraints and variables in your model.

If you choose to display the model, LINGO will place a copy of the generated model in a new window, which you may scroll through to examine, print, or save to disk. If you choose not to display the model, LINDO will generate the model without displaying it, but will store the generated model for later use by the appropriate solver.

PICTURE Ctrl+K

Use the *PICTURE* command from the *LINGO* menu or press *Ctrl+K* to display a model in matrix form. Viewing the model in matrix form can be helpful in identifying special structure in your model.

MODEL STATISTICS Ctrl+E

Use the *MODEL STATISTICS* command from the *LINGO* menu or press *Ctrl+E* to list summary statistics for your model. The statistics shown vary slightly depending on whether the model you're working with is linear or nonlinear.

LOOK... Ctrl+L

Use the *LOOK* command from the *LINGO* menu or press *Ctrl+L* to generate a report containing your model's formulation. The *LOOK* command lets you choose all or selected lines of a model for viewing. This command is mainly of interest if you are working in command line mode rather than the more typical Windows environment.

2.2.4 Windows Menu**COMMAND WINDOW Ctrl+1**

Use the *COMMAND WINDOW* command from the *Windows* menu or press *Ctrl+1* to open LINGO's Command Window. The Command Window gives you access to LINGO's command line interface. In general, Windows users will not need to make use of the Command Window. It is provided for users who may want to put together application-specific "products" that make use of LINGO through Command Window scripts to control the program. Please refer to your help file or user's manual for more information on the command line commands.

STATUS WINDOW Ctrl+2

Use the *STATUS WINDOW* command from the *Windows* menu or press *Ctrl+2* to open LINGO's Solver Status window.

SEND TO BACK Ctrl+B 

Use the *SEND TO BACK* command from the *Windows* menu, click on the button, or press *Ctrl+B* to send the active (frontmost) window to the back. This command is very useful for switching between a Model window and a Report Window.

CLOSE ALL Ctrl+3 

Use the *CLOSE ALL* command from the *Windows* menu, click on the button, or press *Ctrl+3* to close all open model windows and dialog boxes.

TILE Ctrl+4

Use the *TILE* command from the *Windows* menu or press *Ctrl+4* to arrange all open windows, so they each occupy the same amount of space within the LINGO program window.

CASCADE Ctrl+5

Use the *CASCADE* command from the *Windows* menu or press *Ctrl+5* to arrange all open windows in a cascade from upper left to lower right with the currently active window on top.

ARRANGE ICONS Ctrl+6

Use the *ARRANGE ICONS* command from the *Windows* menu or press *Ctrl+6* to move icons representing any minimized windows, so they are arranged across the bottom of the screen.

LIST OF WINDOWS

A list of all open windows appears at the bottom of the Windows menu, with the currently active window checked. You may select a window from the list to bring it to the front.

2.2.5 Help Menu

HELP TOPICS

Use the *HELP TOPICS* command from the *Help* menu, or click on the first question mark button to open LINGO help to the Contents section. Press the second button (with the arrow) to invoke context-sensitive help. Once the cursor has changed to the question mark, selecting any command will take you to help for that command.

REGISTER

Use the *REGISTER* command from the *Help* menu to register your version of LINGO online. You will need a connection to the internet open for this command to work. Enter your personal information in the dialog box supplied and select the register button. Your information will be sent directly to LINDO Systems via the Internet.

LINDO Systems is constantly working to make our products faster and easier to use. Registering your software with LINDO ensures that you will be kept up-to-date on the latest enhancements and other product news.

AUTOUPDATE

Use the *AUTOUPDATE* command from the *Help* menu to have LINGO automatically check every time you start the LINGO software whether there is a more recent version of LINGO available for download on the LINDO Systems website. You will need a connection to the internet open for this command to work.

ABOUT LINGO...

Use the *ABOUT LINGO* command from the *Help* menu to view information about the version of LINGO you are currently using (e.g., the release number, constraint limit, variable limit, and memory limit).

2.2.6 Summary

This is not intended to be an exhaustive description of the commands available in the Windows version of LINGO. Please refer to your help file or user's manual for a more in-depth analysis.

2.3 Getting Started on a Small Problem

When you start LINGO for Windows, the program opens an *<untitled>* window for you. For purposes of introduction, let's enter the Enginola problem we looked at in the previous chapter directly into this *<untitled>* window:

```
MAX = (20 * A) + (30 * C);
!note that the parentheses aren't needed, because LINGO;
!will do multiplication and division first;
A < 60;
C < 50;
A + 2 * C < 120;
```

Note, even though the strict inequality, “<”, was entered above, LINGO interprets it as the loose inequality, “≤”. The reason is that typical keyboards have only the strict inequalities, < and >. You

may, and in fact are encouraged to, use the two symbols “<=” to emphasize an inequality is of a less-than-or-equal-to nature. Also, notice comments are preceded by the exclamation mark (!). A semicolon (;) terminates a comment.

Click on the Solve/“bullseye” button , use the *Solve* command from the *Solve* menu, or press *Ctrl+U* to solve the model. While solving, LINGO will show the Solver Status Window with information about the model and the solution process. When it’s done solving, the “State” field should read “Global Optimum”. Then, click on the “Close” button to close the Solver Status Window:

The following solution is now in a Report Window:

```
Optimal solution found at step:          1
Objective value:                       2100.000
Variable           Value           Reduced Cost
   A             60.00000           0.0000000
   C             30.00000           0.0000000
Row   Slack or Surplus   Dual Price
  1           2100.000         1.000000
  2           0.0000000         5.000000
  3           20.00000         0.0000000
  4           0.0000000        15.000000
```

Editing the model is simply a matter of finding and changing the variable, coefficient, or direction you want to change. Any changes will be taken into account the next time that you solve the model.

Click on the  button, use the *Save* command from the *File* menu, or press *Ctrl+S* to save your work.

2.4 Integer Programming with LINGO

Fairly shortly after you start looking at problems for which optimization might be applicable, you discover the need to restrict certain variables to integer values (i.e., 0, 1, 2, etc.). LINGO allows you to identify such variables. We give an introductory treatment here. It is discussed more thoroughly in Chapter 11, *Formulating and Solving Integer Programs*. Integer variables in LINGO can be either 0/1 or general. Variables restricted to the values 0 or 1 are identified with the *@BIN* specification. Variables that may be 0, 1, 2, etc., are identified with the *@GIN* specification.

In the following model, the variables *TOM*, *DICK*, and *HARRY* are restricted to be 0 or 1:

```
MAX = 4 * TOM + 3 * DICK + 2 * HARRY;
      2.5 * TOM           + 3.1 * HARRY <= 5;
      .2 * TOM + .7 * DICK + .4 * HARRY <= 1;
@BIN (TOM);
@BIN (DICK);
@BIN (HARRY);
```

After solving, to see the solution, choose *Solution* from the *Reports* menu, or click on the  button, and choose *All Values*. The Report Window displays the following:

```

Optimal solution found at step:      1
Objective value:                    7.000000
Branch count:                       0

Variable      Value      Reduced Cost
TOM           1.000000    -4.000000
DICK          1.000000    -3.000000
HARRY        0.000000     -2.000000

Row   Slack or Surplus   Dual Price
  1       7.000000        1.000000
  2       2.500000        0.000000
  3       0.100000        0.000000

```

General integers, which can be 0, 1, 2, etc., are identified in analogous fashion by using *@GIN* instead of *@BIN*, for example:

```
@GIN (TONIC) ;
```

This restricts the variable *TONIC* to 0, 1, 2, 3,

The solution method used is branch-and-bound. It is an intelligent enumeration process that will find a sequence of better and better solutions. As each one is found, the Status Window will be updated with the objective value and a bound on how good a solution might still remain. After the enumeration is complete, various commands from the Reports menu can be used to reveal information about the best solution found.

Let's look at a slightly modified version of the original Enginola problem and see how the GIN specification might help:

```

MAX = 20 * A + 30 * C;
A < 60;
C < 50;
A + 2 * C < 115;

```

Notice the capacity of 115 on the labor constraint (Row 4):

```

Optimal solution found at step:      1
Objective value:                    2025.000

Variable      Value      Reduced Cost
A             60.00000    0.000000
C             27.50000    0.000000

Row   Slack or Surplus   Dual Price
  1       2025.000        1.000000
  2       0.000000        5.000000
  3       22.50000        0.000000
  4       0.000000       15.00000

```

Note that a fractional quantity is recommended for C . If fractional quantities are undesirable, declare A and C as general integer variables:

```

MAX = 20 * A + 30 * C;
A < 60;
C < 50;
A + 2 * C < 115;
@GIN( A);
@GIN( C);

```

Solving results in the following:

```

Optimal solution found at step:          4
Objective value:                        2020.000
Branch count:                            1

```

Variable	Value	Reduced Cost
A	59.000000	-20.000000
C	28.000000	-30.000000

Row	Slack or Surplus	Dual Price
1	2020.000	1.000000
2	1.000000	0.000000
3	22.000000	0.000000
4	0.000000	0.000000

2.4.1 Warning for Integer Programs

Although the integer programming (IP) capability is very powerful, it requires skill to use effectively. In contrast to linear programs, just because you can formulate a problem as an integer program, does not mean that it can be solved in very little time. It is very easy to prepare a bad formulation for an essentially easy problem. A bad formulation may require intolerable amounts of computer time to solve. Therefore, you should have access to someone who is experienced in IP formulations if you plan to make use of the IP capability. Good formulations of integer programs are discussed further in Chapter 11, *Formulating and Solving Integer Programs*.

2.5 Solving an Optimization Model

Solving a linear or integer program is a numerically intensive process. We do not discuss the implementation details of the solution algorithms. Writing an efficient solver requires several person-years of effort. For a good introduction to some of the algorithms, see Martin (1999) or Greenberg (1978).

Even though commercial optimization is quite robust, good practice is to avoid using extremely small or extremely large numbers in a formulation. You should try to “scale” the model, so there are no extremely small or large numbers. You should not measure weight in ounces one place and volume in cubic miles somewhere else in the same problem). A rule of thumb is there should be no nonzero coefficient whose absolute value is greater than 100,000 or less than 0.0001. If LINGO feels the model is poorly scaled, it will display a warning. You can usually disregard this warning. However, it is good practice to choose your units of measure appropriately, so this message does not appear.

2.6 Problems

1. Recall the Enginola/Astro/Cosmo problem of the previous chapter. Suppose we add the restriction that only an even number (0, 2, 4...) of Cosmos are allowed. Show how to exploit the *@GIN* command to represent this feature. Note, this kind of restriction sometimes arises in the manufacture of plastic wrap. The product starts out as a long hollow tube. It is flattened and then two resulting edges are cut off to leave you with two flat pieces. Thus, the number of units produced is always a multiple of 2.
2. Using your favorite text editor, enter the Enginola formulation. Save it as a simple, unformatted text file. Start up LINGO, read the model into LINGO, and solve it.
3. Continuing from (2), use LINGO to prepare an output file containing both the formulation and solution. Read this file into your favorite text editor and print it.

Analyzing Solutions

3.1 Economic Analysis of Solution Reports

A substantial amount of interesting economic information can be gleaned from the solution report of a model. In addition, optional reports, such as range analysis, can provide further information. The usual use of this information is to do a quick “what if” analysis. The typical kinds of what if questions are:

- (a) What would be the effect of changing a capacity or demand?
- (b) What if a new opportunity becomes available? Is it a worthwhile opportunity?

3.2 Economic Relationship Between Dual Prices and Reduced Costs

The reader hungering for unity in systems may convince himself or herself that a reduced cost is really a dual price born under the wrong sign. Under our convention, the reduced cost of a variable x is really the dual price with the sign reversed on the constraint $x \geq 0$. Recall the reduced cost of the variable x measures the rate at which the solution value deteriorates as x is increased from zero. The dual price on $x \geq 0$ measures the rate at which the solution value improves as the right-hand side (and thus x) is increased from zero.

Our knowledge about reduced costs and dual prices can be restated as:

Reduced cost of an (unused) activity: amount by which profits will decrease if one unit of this activity is forced into the solution.

Dual price of a constraint: one unit reduces amount by which profits will decrease if the availability of the resource associated with this constraint.

We shall argue and illustrate that the reduced cost of an activity is really its net opportunity cost if we “cost out” the activity using the dual prices as charges for resource usage. This sounds like good economic sense. If one unit of an activity is forced into the solution, it effectively reduces the availability of the resources it uses. These resources have an imputed value by way of the dual prices. Therefore, the activity should be charged for the value used. Let’s look at an example and check if the argument works.

3.2.1 The Costing Out Operation: An Illustration

Suppose Enginola is considering adding a video recorder to its product line. Market Research and Engineering estimate the direct profit contribution of a video recorder as \$47 per unit. It would be manufactured on the Astro line and would require 3 hours of labor. If it is produced, it will force the reduction of both Astro production (because it competes for a production line) and Cosmo production (because it competes for labor). Is this tradeoff worthwhile? It looks promising. The video recorder makes more dollars per hour of labor than a Cosmo and it makes more efficient use of Astro capacity than Astros. Recall the dual prices on the Astro and labor capacities in the original solution were \$5 and \$15. If we add this variable to the model, it would have a +47 in the objective function, a +1 in row 2 (the Astro capacity constraint), and a +3 in row 4 (the labor capacity constraint). We can “cost out” an activity or decision variable by charging it for the use of scarce resources. What prices should be charged? The obvious prices to use are the dual prices. The +47 profit contribution can be thought of as a negative cost. The costing out calculations can be arrayed as in the little table below:

Row	Coefficient	Dual Price	Charge
1	-47	1	-47
2	1	+5	+5
3	0	0	0
4	3	15	+45
Total opportunity cost =			+3

Thus, a video recorder has an opportunity cost of \$3. A negative one (-1) is applied to the 47 profit contribution because a profit contribution is effectively a negative cost. The video recorder’s net cost is positive, so it is apparently not worth producing.

The analysis could be stopped at this point, but out of curiosity we’ll formulate the relevant LP and solve it. If V = number of video recorders to produce, then we wish to solve:

$$\begin{aligned} \text{MAX} &= 20 * A + 30 * C + 47 * V; \\ A &+ V &\leq 60; \\ C &&\leq 50; \\ A + 2 * C + 3 * V &\leq 120; \end{aligned}$$

The solution is:

Optimal solution found at step:		1
Objective value:		2100.000
Variable	Value	Reduced Cost
A	60.000000	0.000000
C	30.000000	0.000000
V	0.000000	3.000000
Row	Slack or Surplus	Dual Price
1	2100.000000	1.000000
2	0.000000	5.000000
3	20.000000	0.000000
4	0.000000	15.000000

Video recorders are not produced. Notice the reduced cost of V is \$3, the value we computed when we “costed out” V . This is an illustration of the following relationship:

The reduced cost of an activity equals the weighted sum of its resource usage rates minus its profit contribution rate, where the weights applied are the dual prices. A

“min” objective is treated as having a dual price of +1. A “max” objective is treated as having a dual price of -1 in the costing out process.

Notice that the dual prices of an LP fully allocate the total profit to all the scarce resources, i.e., for the above example, $5 * 60 + 0 * 50 + 15 * 120 = 2100$.

3.2.2 Dual Prices, LaGrange Multipliers, KKT Conditions, and Activity Costing

When you solve a continuous optimization problem with LINGO or What'sBest!, you can optionally have dual prices reported for each constraint. For simplicity, assume that our objective is to maximize and all constraints are less-than-or-equal-to when all variable expressions are brought to the left-hand side. The dual price of a constraint is then the rate of change of the optimal objective value with respect to the right-hand side of the constraint. This is a generalization to inequality constraints of the idea of a LaGrange multiplier for equality constraints. This idea has been around for more than 100 years. To illustrate, consider the following slightly different, nonlinear problem:

```
[ROW1] MAX = 40*( X+1)^.5 + 30*( Y+1)^.5 + 25*( Z+1)^.5;
[ROW2]           X                + 15* Z   <= 45;
[ROW3]           Y                + Z     <= 45;
[ROW4]           X* X            + 3* Y*Y   + 9 * Z*Z <= 3500;
```

We implicitly assume that $X, Y, Z \geq 0$.

When solved, you get the solution:

Objective value =	440.7100	
Variable	Value	Reduced Cost
X	45.00000	0.0000000
Y	22.17356	0.0000000
Z	0.0000000	0.1140319
Row	Slack or Surplus	Dual Price
ROW2	0.0000000	0.8409353
ROW3	22.82644	0.0000000
ROW4	0.0000000	0.02342115

For example, the dual price of .8409353 on *ROW2* implies that if the RHS of *ROW2* is increased by a small amount, epsilon, the optimal objective value will increase by about .8409353 * epsilon.

When trying to understand why a particular variable or activity is unused (i.e., at zero), a useful perspective is that of “costing out the activity”. We give the variable “credit” for its incremental contribution to the objective and charge it for its incremental usage of each constraint, where the charging rate applied is the dual price of the constraint. The incremental contribution, or usage, is simply the partial derivative of the LHS with respect to the variable. The costing out of variable *Z* is illustrated below:

Row	<u>Partial w.r.t Z</u>	<u>Dual price</u>	<u>Total charge</u>
ROW1	12.5	-1	-12.5
ROW2	15	.8409353	12.614029
ROW3	1	0	0
ROW4	0	.02342115	0
		Net (Reduced Cost):	.11403

On the other hand, if we do the same costing out for X , we get:

Row	Partial w.r.t X	Dual price	Total charge
ROW1	2.9488391	-1	-2.9488391
ROW2	1	.8409353	.8409353
ROW3	0	0	0
ROW4	90	.02342115	2.107899
Net (Reduced Cost):			0

These two computations are illustrations of the Karush/Kuhn/Tucker (KKT) conditions, namely, in an optimal solution:

- a variable that has a positive reduced cost will have a value of zero;
- a variable that is used (i.e., is strictly positive) will have a reduced cost of zero;
- a “ \leq ” constraint that has a positive dual price will have a slack of zero;
- a “ \leq ” constraint that has strictly positive slack, will have a dual price of zero.

These conditions are sometimes also called complementary slackness conditions.

3.3 Range of Validity of Reduced Costs and Dual Prices

In describing reduced costs and dual prices, we have been careful to limit the changes to “small” changes. For example, if the dual price of a constraint is \$3/hour, then increasing the number of hours available will improve profits by \$3 for each of the first few hours (possibly less than one) added. However, this improvement rate will generally not hold forever. We might expect that, as we make more hours of capacity available, the value (i.e., the dual price) of these hours would not increase and might decrease. This might not be true for all situations, but for LP’s it is true that increasing the right-hand side of a constraint cannot cause the constraint’s dual price to increase. The dual price can only stay the same or decrease.

As we change the right-hand side of an LP, the optimal values of the decision variables may change. However, the dual prices and reduced costs will not change as long as the “character” of the optimal solution does not change. We will say the character changes (mathematicians say the basis changes) when either the set of nonzero variables or the set of binding constraints (i.e., have zero slack) changes. In summary, as we alter the right-hand side, the same dual prices apply as long as the “character” or “basis” does not change.

Most LP programs will optionally supplement the solution report with a range (i.e., sensitivity analysis) report. This report indicates the amounts by which individual right-hand side or objective function coefficients can be changed unilaterally without affecting the character or “basis” of the optimal solution. Recall the previous model:

$$\begin{aligned}
 \text{MAX} &= 20 * A + 30 * C + 47 * V; \\
 A &+ V &\leq 60; \\
 &C &\leq 50; \\
 A + 2 * C + 3 * V &\leq 120;
 \end{aligned}$$

To obtain the sensitivity report, while in the window with the program, choose *Range* from the *LINGO* menu. The sensitivity report for this problem appears below:

Ranges in which the basis is unchanged:

Objective Coefficient Ranges			
Variable	Current Coefficient	Allowable Increase	Allowable Decrease
A	20.00000	INFINITY	3.000000
C	30.00000	10.00000	3.000000
V	47.00000	3.000000	INFINITY

Right-hand Side Ranges			
Row	Current RHS	Allowable Increase	Allowable Decrease
2	60.00000	60.00000	40.00000
3	50.00000	INFINITY	20.00000
4	120.0000	40.00000	60.00000

Again, we find two sections, one for variables and the second for rows or constraints. The 3 in the *A* row of the report means the profit contribution of *A* could be decreased by up to \$3/unit without affecting the optimal amount of *A* and *C* to produce. This is plausible because one Astro and one Cosmo together make \$50 of profit contribution. If the profit contribution of this pair is decreased by \$3 (to \$47), then a *V* would be just as profitable. Note that one *V* uses the same amount of scarce resources as one Astro and one Cosmo together. The *INFINITY* in the same section of the report means increasing the profitability of *A* by any positive amount would have no effect on the optimal amount of *A* and *C* to produce. This is intuitive because we are already producing *A*'s to their upper limit.

The "allowable decrease" of 3 for variable *C* follows from the same argument as above. The allowable increase of 10 in the *C* row means the profitability of *C* would have to be increased by at least \$10/unit (thus to \$40/unit) before we would consider changing the values of *A* and *C*. Notice at \$40/unit for *C*'s, the profit per hour of labor is the same for both *A* and *C*.

In general, if the *objective function coefficient* of a single variable is *changed within the range* specified in the first section of the range report, then the optimal values of the *decision variables*, *A*, *C*, and *V*, in this case, *will not change*. The dual prices, reduced cost and profitability of the solution, however, may change.

In a complementary sense, if the *right-hand side* of a single constraint is *changed within the range* specified in the second section of the range report, then the *optimal values* of the dual prices and reduced costs *will not change*. However, the values of the decision variables and the profitability of the solution may change.

For example, the second section tells us that, if the right-hand side of row 3 (the constraint $C \leq 50$) is decreased by more than 20, then the dual prices and reduced costs will change. The constraint will then be $C \leq 30$ and the character of the solution changes in that the labor constraint will no longer be binding. The right-hand side of this constraint ($C \leq 50$) could be increased an infinite amount, according to the range report, without affecting the optimal dual prices and reduced costs. This makes sense because there already is excess capacity on the Cosmo line, so adding more capacity should have no effect.

40 Chapter 3 Analyzing Solutions

Let us illustrate some of these concepts by re-solving our three-variable problem with the amount of labor reduced by 61 hours down to 59 hours. The formulation is:

$$\begin{aligned} \text{MAX} &= 20 * A + 30 * C + 47 * V; \\ &A + V \leq 60; \\ &C \leq 50; \\ &A + 2 * C + 3 * V \leq 59; \end{aligned}$$

The solution is:

Optimal solution found at step:		1
Objective value:		1180.000
Variable	Value	Reduced Cost
A	59.00000	0.000000
C	0.000000	10.00000
V	0.000000	13.00000
Row	Slack or Surplus	Dual Price
1	1180.000	1.000000
2	1.000000	0.000000
3	50.00000	0.000000
4	0.000000	20.00000

Ranges in which the basis is unchanged:

Variable	Objective Coefficient Ranges		
	Current Coefficient	Allowable Increase	Allowable Decrease
A	20.00000	INFINITY	4.333333
C	30.00000	10.00000	INFINITY
V	47.00000	13.00000	INFINITY

Row	Right-hand Side Ranges		
	Current RHS	Allowable Increase	Allowable Decrease
2	60.00000	INFINITY	1.000000
3	50.00000	INFINITY	50.00000
4	59.00000	1.000000	59.00000

First, note that, with the reduced labor supply, we no longer produce any Cosmos. Their reduced cost is now \$10/unit, which means, if their profitability were increased by \$10 to \$40/unit, then we would start considering their production again. At \$40/unit for Cosmos, both products make equally efficient use of labor.

Also note, since the right-hand side of the labor constraint has reduced by more than 60, most of the dual prices and reduced costs have changed. In particular, the dual price or marginal value of labor is now \$20 per hour. This is because an additional hour of labor would be used to produce one more \$20 Astro. You should be able to convince yourself the marginal value of labor behaves as follows:

Labor Available	Dual Price	Reason
0 to 60 hours	\$20/hour	Each additional hour will be used to produce one \$20 Astro.
60 to 160 hours	\$15/hour	Each additional hour will be used to produce half a \$30 Cosmo.
160 to 280 hours	\$13.5/hour	Give up half an Astro and add half of a V for profit of $0.5(-20 + 47)$.
More than 280 hours	\$0	No use for additional labor.

In general, the dual price on any constraint will behave in the above stepwise decreasing fashion.

Figures 3.1 and 3.2 give a global view of how total profit is affected by changing either a single objective coefficient or a single right-hand side. The artists in the audience may wish to note that, for a maximization problem:

- Optimal total profit as a function of a single objective coefficient always has a bowl shape. Mathematicians say it is a convex function.
- Optimal total profit as a function of a single right-hand side value always has an inverted bowl shape. Mathematicians say it is a concave function.

For some problems, as in Figures 3.1 and 3.2, we only see half of the bowl. For minimization problems, the orientation of the bowl in (a) and (b) is simply reversed.

When we solve a problem for a particular objective coefficient or right-hand side value, we obtain a single point on one of these curves. A range report gives us the endpoints of the line segment on which this one point lies.

Figure 3.1 Total Profit vs. Profit Contribution per Unit of Activity V

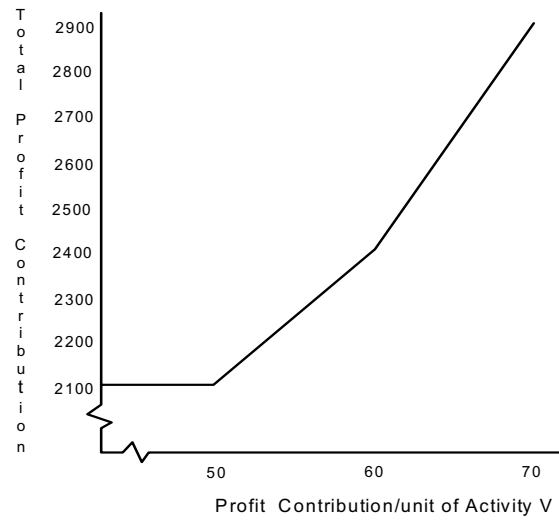
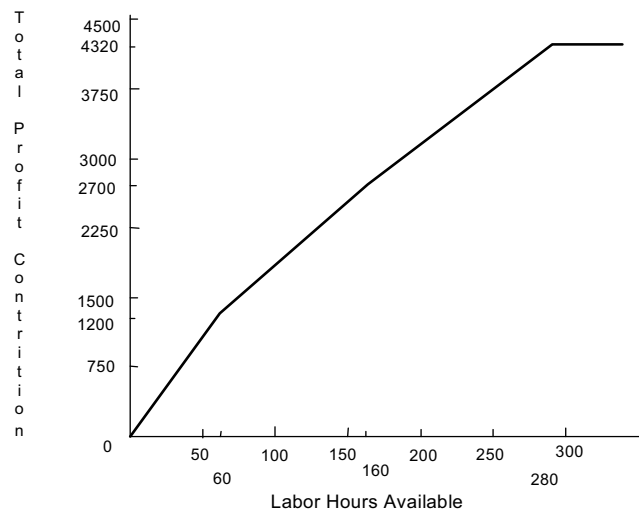

Figure 3.2 Profit vs. Labor Available



3.3.1 Predicting the Effect of Simultaneous Changes in Parameters—The 100% Rule

The information in the range analysis report tells us the effect of changing a single cost or resource parameter. The range report for the Enginola problem is presented as an example:

Ranges in which the basis is unchanged:			
Objective Coefficient Ranges			
Variable	Current Coefficient	Allowable Increase	Allowable Decrease
A	20.00000	INFINITY	5.000000
C	30.00000	10.00000	30.00000

Right-hand Side Ranges			
Row	Current RHS	Allowable Increase	Allowable Decrease
2	60.00000	60.00000	40.00000
3	50.00000	INFINITY	20.00000
4	120.0000	40.00000	60.00000

The report indicates the profit contribution of an Astro could be decreased by as much as \$5/unit without changing the basis. In this case, this means that the optimal solution would still recommend producing 60 Astros and 30 Cosmos.

Suppose, in order to meet competition, we are considering lowering the price of an Astro by \$3/unit and the price of a Cosmo by \$10/unit. Will it still be profitable to produce the same mix? Individually, each of these changes would not change the solution because $3 < 5$ and $10 < 30$.

However, it is not clear these two changes can be made simultaneously. What does your intuition suggest as a rule describing the simultaneous changes that do not change the basis (mix)?

The 100% Rule. You can think of the allowable ranges as slack, which may be used up in changing parameters. It is a fact that any combination of changes will not change the basis if the sum of percentages of slack used is less than 100%. For the simultaneous changes we are contemplating, we have:

$$\left(\frac{3}{5}\right) \times 100 + \left(\frac{10}{30}\right) \times 100 = 60\% + 33\% = 93.3\% < 100\%$$

This satisfies the condition, so the changes can be made without changing the basis. Bradley, Hax, and Magnanti (1977) have dubbed this rule the 100% rule. Since the value of A and C do not change, we can calculate the effect on profits of these changes as $-3 \times 60 - 10 \times 30 = -480$. So, the new profit will be $2100 - 480 = 1620$.

The altered formulation and its solution are:

$$\begin{aligned} \text{MAX} &= 17 * A + 20 * C; \\ A &\leq 60; \\ C &\leq 50; \\ A + 2 * C &\leq 120; \end{aligned}$$

```

Optimal solution found at step:      1
Objective value:                    1620.000
Variable      Value      Reduced Cost
   A          60.00000      0.0000000
   C          30.00000      0.0000000
Row   Slack or Surplus      Dual Price
  1         1620.000          1.0000000
  2           0.0000000          7.0000000
  3          20.00000          0.0000000
  4           0.0000000          10.0000000

```

3.4 Sensitivity Analysis of the Constraint Coefficients

Sensitivity analysis of the right-hand side and objective function coefficients is somewhat easy to understand because the objective function value changes linearly with modest changes in these coefficients. Unfortunately, the objective function value may change nonlinearly with changes in constraint coefficients. However, there is a very simple formula for approximating the effect of small changes in constraint coefficients. Suppose we wish to examine the effect of decreasing by a small amount e the coefficient of variable j in row i of the LP. The formula is:

$$(\text{improvement in objective value}) \approx (\text{value of variable } j) \times (\text{dual price of row } i) \times e$$

Example: Consider the problem:

```

MAX = (20 * A) + (30 * C);
A <= 65;
C <= 50;
A + 2 * C <= 115;

```

with solution:

```

Optimal solution found at step:      1
Objective value:                    2050.000
Variable      Value      Reduced Cost
   A          65.00000      0.0000000
   C          25.00000      0.0000000
Row   Slack or Surplus      Dual Price
  1         2050.000          1.0000000
  2           0.0000000          5.0000000
  3          25.00000          0.0000000
  4           0.0000000          15.0000000

```

Now, suppose it is discovered that the coefficient of C in row 4 should have been 2.01, rather than 2. The formula implies the objective value should be decreased by approximately $25 \times 15 \times .01 = 3.75$.

The actual objective value, when this altered problem is solved, is 2046.269, so the actual decrease in objective value is 3.731.

The formula for the effect of a small change in a constraint coefficient makes sense. If the change in the coefficient is small, then the values of all the variables and dual prices should remain essentially unchanged. So, the net effect of changing the 2 to a 2.01 in our problem is effectively to try to use $25 \times .01$ additional hours of labor. So, there is effectively $25 \times .01$ fewer hours available. However, we have seen that labor is worth \$15 per hour, so the change in profits should be about $25 \times .01 \times 15$, which is in agreement with the original formula.

This type of sensitivity analysis gives some guidance in identifying which coefficient should be accurately estimated. If the product of variable j 's value and row i 's dual price is relatively large, then the coefficient in row i for variable j should be accurately estimated if an accurate estimate of total profit is desired.

3.5 The Dual LP Problem, or the Landlord and the Renter

As you formulate models for various problems, you will probably discover that there are several rather different-looking formulations for the same problem. Each formulation may be correct and may be based on taking a different perspective on the problem. An interesting mathematical fact is, for LP problems, there are always two formulations (more accurately, a multiple of two) to a problem. One formulation is arbitrarily called the primal and the other is referred to as the dual. The two different formulations arise from two different perspectives one can take towards a problem. One can think of these two perspectives as the landlord's and the renter's perspectives.

In order to motivate things, consider the following situations. Some textile "manufacturers" in Italy own no manufacturing facilities, but simply rent time as needed from firms that own the appropriate equipment. In the U.S., a similar situation exists in the recycling of some products. Firms that recycle old telephone cable may simply rent time on the stripping machines that are needed to separate the copper from the insulation. This rental process is sometimes called "tolling". In the perfume industry, many of the owners of well-known brands of perfume own no manufacturing facilities, but simply rent time from certain chemical formulation companies to have the perfumes produced as needed. The basic feature of this form of industrial organization is that the owner of the manufacturing resources never owns either the raw materials or the finished product.

Now, suppose you want to produce a product that can use the manufacturing resources of the famous Enginola Company, manufacturer of Astros, Cosmos, and Video Recorders. You would thus like to rent production capacity from Enginola. You need to deduce initial reasonable hourly rates to offer to Enginola for each of its three resources: Astro line capacity, Cosmo line capacity, and labor. These three hourly rates are your decision variables. You in fact would like to rent all the capacity on each of the three resources. Thus, you want to minimize the total charge from renting the entire capacities (60, 50, and 120). If your offer is to succeed, you know your hourly rates must be sufficiently high, so none of Enginola's products are worth producing (e.g., the rental fees foregone by producing an Astro should be greater than 20). These "it's better to rent" conditions constitute the constraints.

Formulating a model for this problem, we define the variables as follows:

PA = price per unit to be offered for Astro line capacity,
 PC = price per unit to be offered for Cosmo line capacity,
 PL = price per unit to be offered for labor capacity.

Then, the appropriate model is:

The Dual Problem:
 MIN = 60 * PA + 50 * PC + 120 * PL;
 !ASTRO; PA + PL > 20;
 !COSMO; PC + 2*PL > 30;
 !VR; PA + 3 * PL > 47;

The three constraints force the prices to be high enough, so it is not profitable for Enginola to produce any of its products.

The solution is:

```

Optimal solution found at step:          2
Objective value:                        2100.000
Variable      Value      Reduced Cost
  PA          5.000000      0.0000000
  PC          0.000000      20.000000
  PL          15.00000      0.0000000
  Row  Slack or Surplus      Dual Price
    1          2100.000          1.000000
    2           0.000000         -60.00000
    3           0.000000         -30.00000
    4           3.000000          0.0000000

```

Recall the original, three-product Enginola problem was:

The Primal Problem:

```

MAX = 20 * A + 30 * C + 47 * V;
A +          V <= 60;
          C    <= 50;
A + 2 * C + 3 * V <= 120;

```

with solution:

```

Optimal solution found at step:          1
Objective value:                        2100.000
Variable      Value      Reduced Cost
  A          60.00000      0.0000000
  C          30.00000      0.0000000
  V           0.000000      3.0000000
  Row  Slack or Surplus      Dual Price
    1          2100.000          1.000000
    2           0.000000          5.000000
    3          20.00000          0.0000000
    4           0.000000         15.000000

```

Notice the two solutions are essentially the same, except prices and decision variables are reversed. In particular, note the price the renter should pay is exactly the same as Enginola's original profit contribution. This "Minimize the rental cost of the resources, subject to all activities being unprofitable" model is said to be the dual problem of the original "Maximize the total profit, subject to not exceeding any resource availabilities" model. The equivalence between the two solutions shown above always holds. Upon closer scrutiny, you should also notice the dual formulation is essentially the primal formulation "stood on its ear," or its transpose, in fancier terminology.

Why might the dual model be of interest? The computational difficulty of an LP is approximately proportional to m^2n , where m = number of rows and n = number of columns. If the number of rows in the dual is substantially smaller than the number of rows in the primal, then one may prefer to solve the dual.

Additionally, certain constraints, such as simple upper bounds (e.g., $x \leq 1$) are computationally less expensive than arbitrary constraints. If the dual contains only a small number of arbitrary constraints, then it may be easier to solve the dual even though it may have a large number of simple constraints.

The term “dual price” arose because the marginal price information to which this term is applied is a decision variable value in the dual problem.

We can summarize the idea of dual problems as follows. If the original or primal problem has a Maximize objective with \leq constraints, then its dual has a Minimize objective with \geq constraints. The dual has one variable for each constraint in the primal and one constraint for each variable in the primal. The objective coefficient of the k th variable of the dual is the right-hand side of the k th constraint in the primal. The right-hand side of constraint k in the dual is equal to the objective coefficient of variable k in the primal. Similarly, the coefficient in row i of variable j in the dual equals the coefficient in row j of variable i in the primal.

In order to convert all constraints in a problem to the same type, so one can apply the above, note the following two transformations:

- (1) The constraint $2x + 3y = 5$ is equivalent to the constraints $2x + 3y \geq 5$ and $2x + 3y \leq 5$;
- (2) The constraint $2x + 3y \geq 5$ is equivalent to $-2x - 3y \leq -5$.

Example: Write the dual of the following problem:

$$\begin{array}{ll} \text{Maximize} & 4x - 2y \\ \text{subject to} & 2x + 6y \leq 12 \\ & 3x - 2y = 1 \\ & 4x + 2y \geq 5 \end{array}$$

Using transformations (1) and (2) above, we can rewrite this as:

$$\begin{array}{ll} \text{Maximize} & 4x - 2y \\ \text{subject to} & 2x + 6y \leq 12 \\ & 3x - 2y \leq 1 \\ & -3x + 2y \leq -1 \\ & -4x - 2y \leq -5 \end{array}$$

Introducing the dual variables r , s , t , and u , corresponding to the four constraints, we can write the dual as:

$$\begin{array}{ll} \text{Minimize} & 12r + s - t - 5u \\ \text{subject to} & 2r + 3s - 3t - 4u \geq 4 \\ & 6r - 2s + 2t - 2u \geq -2 \end{array}$$

3.6 Problems

1. The Enginola Company is considering introducing a new TV set, the Quasi. The expected profit contribution is \$25 per unit. This unit is produced on the Astro line. Production of one Quasi requires 1.6 hours of labor. Using only the original solution below, determine whether it is worthwhile to produce any Quasi's, assuming no change in labor and Astro line capacity.

The original Enginola problem with solution is below.

$$\begin{array}{ll} \text{MAX} = & 20 * A + 30 * C; \\ A & \leq 60; \\ & C \leq 50; \\ A + 2 * C & \leq 120; \end{array}$$

Optimal solution found at step: 1
 Objective value: 2100.000

Variable	Value	Reduced Cost
A	60.00000	0.000000
C	30.00000	0.000000
Row	Slack or Surplus	Dual Price
1	2100.000	1.000000
2	0.000000	5.000000
3	20.00000	0.000000
4	0.000000	15.00000

2. The Judson Corporation has acquired 100 lots on which it is about to build homes. Two styles of homes are to be built, the “*Cape Cod*” and the “*Ranch Home*”. Judson wishes to build these 100 homes over the next nine months. During this time, Judson will have available 13,000 man-hours of bricklayer labor and 12,000 hours of carpenter labor. Each *Cape Cod* requires 200 man-hours of carpentry labor and 50 man-hours of bricklayer labor. Each *Ranch Home* requires 120 hours of bricklayer labor and 100 man-hours of carpentry. The profit contribution of a *Cape Cod* is projected to be \$5,100, whereas that of a *Ranch Home* is projected at \$5,000. When formulated as an LP and solved, the problem is as follows:

$$\begin{aligned} \text{MAX} &= 5100 * C + 5000 * R; \\ C + R &< 100; \\ 200 * C + 100 * R &< 12000; \\ 50 * C + 120 * R &< 13000; \end{aligned}$$

Optimal solution found at step: 0
 Objective value: 502000.0

Variable	Value	Reduced Cost
C	20.00000	0.000000
R	80.00000	0.000000
Row	Slack or Surplus	Dual Price
1	502000.0	1.000000
2	0.000000	4900.000
3	0.000000	1.000000
4	2400.000	0.000000

Ranges in which the basis is unchanged:

Variable	Objective Coefficient Ranges		
	Current Coefficient	Allowable Increase	Allowable Decrease
C	5100.000	4900.000	100.0000
R	5000.000	100.0000	2450.000

Row	Right-hand Side Ranges		
	Current RHS	Allowable Increase	Allowable Decrease
2	100.0000	12.63158	40.00000
3	12000.00	8000.000	2000.000
4	13000.00	INFINITY	2400.000

- (a) A gentleman who owns 15 vacant lots adjacent to Judson’s 100 lots needs some money quickly and offers to sell his 15 lots for \$60,000. Should Judson buy? What assumptions are you making?

- (b) One of Judson's salesmen who is a native of Massachusetts feels certain he could sell the *Cape Cods* for \$2,000 more each than Judson is currently projecting. Should Judson change its planned mix of homes? What assumptions are inherent in your recommendation?
3. Jack Mazzola is an industrial engineer with the Enginola Company. He has discovered a way of reducing the amount of labor used in the manufacture of a Cosmo TV set from 2 hours per set to 1.92 hours per set by replacing one of the assembled portions of the set with an integrated circuit chip. It is not clear at the moment what this chip will cost. Based solely on the solution report below (i.e., do not solve another LP), answer the following questions:
- (a) Assuming labor supply is fixed, what is the approximate value of one of these chips in the short run?
- (b) Give an estimate of the approximate increase in profit contribution per day of this change, exclusive of chip cost.

$$\begin{aligned} \text{MAX} &= 20 * A + 30 * C; \\ A &\leq 60; \\ C &\leq 50; \\ A + 2 * C &\leq 120; \end{aligned}$$

Optimal solution found at step: 1
Objective value: 2100.000

Variable	Value	Reduced Cost
A	60.00000	0.000000
C	30.00000	0.000000

Row	Slack or Surplus	Dual Price
1	2100.000	1.000000
2	0.000000	5.000000
3	20.00000	0.000000
4	0.000000	15.00000

Row	Right-hand Side Ranges		
	Current RHS	Allowable Increase	Allowable Decrease
2	60.00000	60.00000	40.00000
3	50.00000	INFINITY	20.00000
4	120.0000	40.00000	60.00000

4. The Bug product has a profit contribution of \$4100 per unit and requires 4 hours in the foundry department and 2 hours in the assembly department. The SuperBug has a profit contribution of \$5900 per unit and requires 2 hours in the foundry and 3 hours in assembly. The availabilities in foundry and assembly are 160 hours and 180 hours, respectively. Each hour used in each of foundry and assembly costs \$90 and \$60, respectively. The following is an LP formulation for maximizing profit contribution in this situation:

$$\begin{aligned} \text{MAX} &= 4100 * B + 5900 * S - 90 * F - 60 * A; \\ 4 * B + 2 * S - F &= 0; \\ 2 * B + 3 * S - A &= 0; \\ F &\leq 160; \\ A &\leq 180; \end{aligned}$$

Following is an optimal solution report printed on a typewriter that skipped some sections of the report.

Objective value:

Variable	Value	Reduced Cost
B		73.33325
S	60.00000	
F	120.0000	0.0000000
A	180.0000	0.0000000
Row	Slack or Surplus	Dual Price
1	332400.0	1.000000
2	0.0000000	
3		1906.667
4		0.0000000
5	0.0000000	1846.667

Fill in the missing parts, using just the available information (i.e., without re-solving the model on the computer).

5. Suppose the capacities in the Enginola problem were: Astro line capacity = 45; labor capacity = 100.
 - (a) Allow the labor capacity to vary from 0 to 200 and plot:
 - Dual price of labor as a function of labor capacity.
 - Total profit as a function of labor capacity.
 - (b) Allow the profit contribution/unit of Astros to vary from 0 to 50 and plot:
 - Number of Astros to produce as a function of profit/unit.
 - Total profit as a function of profit/unit.
6. Write the dual problem of the following problem:

$$\begin{aligned}
 &\text{Minimize} && 12q + 5r + 3s \\
 &\text{subject to} && q + 2r + 4s \geq 6 \\
 &&& 5q + 6r - 7s \leq 5 \\
 &&& 8q - 9r + 11s = 10
 \end{aligned}$$

7. The energetic folks at Enginola, Inc. have not been idle. The R & D department has given some more attention to the proposed digital recorder product (code name R) and enhanced it so much that everyone agrees it could be sold for a profit contribution of \$79 per unit. Unfortunately, its production still requires one unit of capacity on both the A(stro) and C(osmo) lines. Even worse, it now requires four hours of labor. The Marketing folks have spread the good word about the Astro and Cosmo products, so a price increase has been made possible. Industrial Engineering has been able to increase the capacity of the two lines. The new ex-marine heading Human Resources has been able to hire a few more good people, so the labor capacity has increased to 135 hours. The net result is that the relevant model is now:

$$\begin{aligned}
 \text{MAX} &= 23 * A + 38 * C + 79 * R; \\
 &A + R \leq 75; \\
 &C + R \leq 65; \\
 &A + 2 * C + 4 * R \leq 135; \\
 \text{END}
 \end{aligned}$$

Without resorting to a computer, answer the following questions, supporting each answer with a one- or two-sentence economic argument that might be understood by your spouse or “significant other.”

- (a) How many A 's should be produced?
- (b) How many C 's should be produced?
- (c) How many R 's should be produced?
- (d) What is the marginal value of an additional hour of labor?
- (e) What is the marginal value/unit of additional capacity on the A line?
- (f) What is the marginal value per unit of additional capacity on the C line?

4

The Model Formulation Process

*Count what is countable, measure what is measurable, and
what is not measurable, make measurable.
Galileo Galilei(1564-1642)*

4.1 The Overall Process

In using any kind of analytical or modeling approach for attacking a problem, there are five major steps:

- 1) Understanding the real problem.
- 2) Formulating a model of the problem.
- 3) Gathering and generating the input data for the model (e.g., per unit costs to be used, etc.).
- 4) Solving or running the model.
- 5) Implementing and interpreting the solution in the real world.

In general, there is a certain amount of iteration over the five (e.g., one does not develop the most appropriate model the first time around). Of the above, the easiest is the solving of the model on the computer. This is not because it is intrinsically easiest, but because it is the most susceptible to mathematical analysis. Steps 1, 3, and 5 are, if not the most difficult, at least the most time consuming. Success with these steps depends to a large extent upon being very familiar with the organization involved (e.g., knowing who knows what the real production rate is on the punch press machine). Step 2 requires the most analytical skill. Steps 1 and 5 require the most people skills.

Formulating good models is an art bordering on a science. The artistic ability is in developing simple models that are nevertheless good approximations of reality. We shall see that there are a number of classes of problems that are well approximated by optimization models.

With all of the above comments in mind, we will devote most of the discussion to formulation of optimization models, stating what universal truths seem to apply for steps (3) and (5), and giving an introduction to the mechanics of step (4).

4.2 Approaches to Model Formulation

We take two approaches to formulating models:

- 1) Template approach,
- 2) Constructive approach.

The constructive approach is the more fundamental and general. However, readers with less analytic skill may prefer the template approach. The latter is essentially a “model in a can” approach. In this approach, examples of standard applications are illustrated in substantial detail. If you have a problem that closely resembles one of these “template” models, you may be able to adjust it to your situation by making modest changes to the template model. The advantage of this approach is that the user may not need much technical background if there is a template model that closely fits the real situation.

4.3 The Template Approach

You may feel more comfortable and confident in your ability to structure problems if you have a classification of “template” problems to which you can relate new problems you encounter. We will present a classification of about a half dozen different categories of problems. In practice, a large real problem you encounter will not fit a single template model exactly, but might require a combination of two or more of the categories. The classification is not exhaustive, so you may encounter or develop models that seem to fit none of these templates.

4.3.1 Product Mix Problems

Product mix problems are the problem types typically encountered in introductory LP texts. There are a collection of products that can be sold and a finite set of resources from which these products are made. Associated with each product are a profit contribution rate and a set of resource usage rates. The objective is to find a mix of products (amount of each product) that maximizes profit, subject to not using more resources than are available.

These problems are always of the form “Maximize profit subject to less-than-or-equal-to constraints”.

4.3.2 Covering, Staffing, and Cutting Stock Problems

Covering, staffing, and cutting stock problems are complementary (in the jargon, they are called dual) to product mix problems in that their form is “Minimize cost subject to greater-than-or-equal-to constraints”. The variables in this case might correspond to the number of people hired for various shifts during the day. The constraints arise from the fact that the mix of variables chosen must “cover” the requirements during each hour of the day.

4.3.3 Blending Problems

Blending problems arise in the food, feed, metals, and oil refining industries. The problem is to mix or blend a collection of raw materials (e.g., different types of meats, cereal grains, or crude oils) into a finished product (e.g., sausage, dog food, or gasoline). The cost per unit of the finished product is minimized and it is subject to satisfying certain quality constraints (e.g., percent protein \geq 15 percent).

4.3.4 Multiperiod Planning Problems

Multiperiod planning problems constitute perhaps the most important class of models. These models take into account the fact that the decisions made in this period partially determine which decisions are allowable in future periods. The submodel used each period may be a product mix problem, a blending problem, or some other type. These submodels are usually tied together by means of inventory variables (e.g., the inventory of raw materials, finished goods, cash, or loans outstanding) that are carried from one period to the next.

4.3.5 Network, Distribution, and PERT/CPM Models

Network LP models warrant special attention for two reasons: (a) they have a particularly simple form, which makes them easy to describe as a graph or network, and (b) specialized and efficient solution procedures exist for solving them. They, therefore, tend to be easier to explain and comprehend. Network LPs frequently arise from problems of product distribution. Any enterprise producing a product at several locations and distributing it to many customers may find a network LP relevant. Large problems of this type may be solved rapidly by the specialized procedures.

One of the simplest network problems is finding the shortest route from one point in a network to another. A slight variation on this problem, finding the longest route, happens to be an important component of the project management tools PERT (Program Evaluation and Review Technique) and CPM (Critical Path Method).

Close cousins of network models are input/output and vertically integrated models. General Motors, for example, makes engines in certain plants. These engines might be sold directly to customers, such as industrial equipment manufacturers, or the engines may be used in GM's own cars and trucks. Such a company is said to be vertically integrated. In a vertically integrated model, there is usually one constraint for each type of intermediate product. The constraint mathematically enforces the basic law of physics that the amount used of an intermediate product by various processes cannot exceed the amount of this product produced by other processes. There is usually one decision variable for each type of process available.

If one expands one's perspective to the entire economy, then the models considered tend to be similar to the input/output model popularized by Wassily Leontief (1951). Each industry is described by the input products required and the output products produced. These outputs may in turn be inputs to other industries. The problem is to determine appropriate levels at which each industry should be operated in order to satisfy specific consumption requirements.

4.3.6 Multiperiod Planning Problems with Random Elements

One of the fundamental assumptions of optimization models is that all input data are known with certainty. There are situations, however, where certain key data are highly random. For example, when an oil company makes its fuel oil production decisions for the coming winter, the demand for that fuel oil is very much a random variable. If, however, the distribution probabilities for all the random variables are known, then there is a modeling technique for converting a problem that is an optimization model, except for the random elements, into an equivalent, although possibly larger, deterministic optimization model. Such models are sometimes called stochastic programs.

4.3.7 Financial Portfolio Models

An important application of optimization in the last ten years has been in the design of financial investment portfolios. In its simplest form, it is concerned with how much to invest in a collection of risky investments, so that a good compromise is struck between a high expected return and a low risk.

More complicated applications of this idea are concerned with investing so as to track some popular financial index, such as the S&P 500.

4.3.8 Game Theory Models

Game theory is concerned with the analysis of competitive situations. In its simplest form, a game consists of two players, each of whom has available to them a set of possible decisions. Each player must choose a strategy for making a decision in ignorance of the other player's choice. Some time after a decision is made, each player receives a payoff that depends on which combination of decisions was made. The problem of determining each player's optimal strategy can be formulated as a linear program.

Not all problems you encounter will fit into one of the above categories. Many problems will be combinations of the above types. For example, in a multiperiod planning problem, the single period subproblems may be product mix or blending problems.

4.4 Constructive Approach to Model Formulation

The constructive approach is a set of guidelines for constructing a model from the ground up. This approach requires somewhat more analytical skill, but the rules apply to any situation you are trying to model. The odds are low you will find a template model that exactly matches your real situation. In practice, a combination of these two approaches is needed.

For the constructive approach, we suggest the following three-step approach for constructing a model, which, with apologies to Sam Savage, might be called the ABC's of modeling:

- A. Identify and define the decision variables or *Adjustable cells*. Defining a decision variable includes specifying the units in which it is measured (e.g., tons, hours, etc.). One way of trying to deduce the decision variables is to ask the question: What should be the format of a report that gives a solution to this problem? (For example, the numbers that constitute an answer are: the amount to produce of each product and the amount to use of each ingredient.) The cells in this report are the decision variables.
- B. Define how we measure *Best*. More officially, define our objective or criterion function, including the units in which it is measured. Among useable or feasible solutions, how would preference/goodness (e.g., profit) be measured?
- C. Specify the *Constraints*, including the units in which each is measured. A way to think about constraints is as follows: Given a purported solution to a problem, what numeric checks would you perform to check the validity of the solution?

The majority of the constraints in most problems can be thought of as *sources-equals-uses* constraints. Another common kind of constraint is the *definitional* or *accounting* constraint. Sometimes the distinction between the two is arbitrary. Consider a production setting where we: *i*) start with some beginning inventory of some commodity, *ii*) produce some of that commodity, *iii*) sell some of the commodity, and *iv*) leave some of the commodity in ending inventory. From the sources-equals-uses perspective, we might write:

$$\text{beginning inventory} + \text{production} = \text{sales} + \text{ending inventory}.$$

From the definitional perspective, if we were thinking of how ending inventory is defined, we would write:

$$\text{ending inventory} = (\text{beginning inventory} + \text{production}) - \text{sales}.$$

The two perspectives are in fact mathematically equivalent.

For any application, it is useful to do each of the above in words first. In order to illustrate these ideas, consider the situation in the following example.

4.4.1 Example

Deglo Toys has been manufacturing a line of precision building blocks for children for a number of years. Deglo is faced with a standard end-of-the-year problem known as the build-out problem. It is about to introduce a new line of glow-in-the-dark building blocks. Thus, they would like to deplete their old-technology inventories before introducing the new line. The old inventories consist of 19,900 4-dimple blocks and 29,700 8-dimple blocks. These inventories can be sold off in the form of two different kits: the Master Builder and the Empire Builder. The objective is to maximize the revenue from the sale of these two kits. The Master kit sells for \$16.95, and the Empire kit sells for \$24.95. The Master kit is composed of 30 4-dimple blocks plus 40 8-dimple blocks. The Empire kit is composed of 40 4-dimple blocks plus 85 8-dimple blocks. What is an appropriate model of this problem?

4.4.2 Formulating Our Example Problem

The process for our example problem would be as follows:

- a) The essential decision variables are:
 M = number of master builder kits to assemble and
 E = number of empire builder kits to assemble.
- b) The objective function is to maximize sales revenue (i.e., Maximize $16.95M + 24.95E$).
- c) If someone gave us a proposed solution (i.e., values for M and E), we would check its feasibility by checking that:
 - i. the number of 4-dimple blocks used $\leq 19,900$ and
 - ii. the number of 8-dimple blocks used $\leq 29,700$.

Symbolically, or algebraically, this is:

$$\begin{aligned} 30M + 40E &\leq 19,900 \\ 40M + 85E &\leq 29,700 \end{aligned}$$

In LINGO form, the formulation is:

```
MAX = 16.95 * M + 24.95 * E;
      30 * M   + 40 * E <= 19900;
      40 * M   + 85 * E <= 29700;
```

with solution:

```
Optimal solution found at step:          0
Objective value:                    11478.50
Variable          Value          Reduced Cost
M                  530.0000          0.0000000
E                  100.0000          0.0000000
Row   Slack or Surplus   Dual Price
  1         11478.50         1.000000
  2          0.000000         0.4660526
  3          0.000000         0.7421052E-01
```

Thus, we should produce 530 Master Builders and 100 Empire Builders.

4.5 Choosing Costs Correctly

Choosing costs and profit contribution coefficients in the objective requires some care. In many firms, cost data may not be available at the detailed level required in an optimization model. If available, the “official” cost coefficients may be inappropriate for the application at hand.

The basic rule is fairly simple: The cost coefficient of a variable should be the rate of change of the total cost as the variable changes. We will discuss the various temptations to violate this rule. The two major temptations are sunk costs and joint costs.

4.5.1 Sunk vs. Variable Costs

A *sunk cost* is a cost that has already been incurred or committed to, although not necessarily paid. A *variable cost* is a cost that varies with some activity level. Sunk costs should not appear in any coefficient of a decision variable. Whether a cost is sunk or variable depends closely upon the length of our planning horizon. A general rule is that: In the short run, all costs are sunk, while all costs are variable in the long run. The following example illustrates.

Sunk and Variable Cost Example

A firm prepared a profit contribution table for two of its products, X and Y :

Product:	<u>X</u>	<u>Y</u>
Selling price/unit	\$1000	\$1000
Material cost/unit	\$200	\$300
Labor cost/unit	<u>\$495</u>	<u>\$300</u>
Net Profit contribution	\$305	\$400

These two products use a common assembly facility that has a daily capacity of 80 units. Product specific production facilities limit the daily production of X to 40 units and Y to 60 units. The hourly wage in the company is \$15/ hour for all labor. The obvious model is:

$$\begin{aligned} \text{Max} &= 305 * X + 400 * Y; \\ X &\leq 40; \\ Y &\leq 60; \\ X + Y &\leq 80; \end{aligned}$$

The solution is to produce 60 Y 's and 20 X 's. At \$15 per hour, the total labor required by this solution is $20 \times 495/15 + 60 \times 300/15 = 1860$ hours per day.

Now, let us consider some possible additional details or variations of the above situation. Some firms, such as some automobile manufacturers, have had labor contracts that effectively guarantee a job to a fixed number of employees during the term of the contract (e.g., one year). If the above model is being used to decide how many employees to hire and commit to before signing the contract, then the \$15/hour used above is perhaps appropriate, although it may be too low. In the U.S., the employer also must pay Social Security and Medicare taxes that add close to 8% to the labor bill. In addition, the employer typically also covers the cost of supplemental health insurance for the employee, so the cost of labor is probably closer to \$20 per hour rather than \$15.

Once the contract is signed, however, the labor costs then become sunk, but we now have a constraint that we can use at most 1860 hours of labor per day. The variable profit contributions are now:

Product:	<u>X</u>	<u>Y</u>
Selling price/unit	\$1000	\$1000
Material cost/unit	<u>\$200</u>	<u>\$300</u>
Net Profit contribution	\$800	\$700

Now, X is the more profitable product. Before we jump to the conclusion that we should now produce 40 X 's and 40 Y 's, we must recall that labor capacity is now fixed. The proper, short term, model is now:

$$\begin{aligned} \text{Max} &= 800 * X + 700 * Y; \\ X &\leq 40; \\ Y &\leq 60; \\ X + Y &\leq 80; \\ 33 * X + 20 * Y &\leq 1860; \end{aligned}$$

with solution:

Optimal solution found at step:		1
Objective value:		58000.00
Variable	Value	Reduced Cost
X	20.00000	0.0000000
Y	60.00000	0.0000000
Row	Slack or Surplus	Dual Price
1	58000.00	1.0000000
2	20.00000	0.0000000
3	0.0000000	215.1515
4	0.0000000	0.0000000
5	0.0000000	24.24242

Therefore, we still produce the same mix of products.

Now, suppose in order to be competitive, the selling price of X must be dropped by \$350 to \$650. Also, we still have our labor contract that says we may use up to and must pay for all of 1860 hours of labor per day. The correct model is:

$$\begin{aligned} \text{Max} &= 450 * X + 700 * Y; \\ X &\leq 40; \\ Y &\leq 60; \\ X + Y &\leq 80; \\ 33 * X + 20 * Y &\leq 1860; \end{aligned}$$

with still the same solution of $X = 20$ and $Y = 60$. If we (incorrectly) charge for labor, however, the model is:

$$\begin{aligned} \text{Max} &= -45 * X + 400 * Y; \\ X &\leq 40; \\ Y &\leq 60; \\ X + Y &\leq 80; \\ 33 * X + 20 * Y &\leq 1860; \end{aligned}$$

and we would incorrectly conclude that X should not be produced.

There are many planning situations similar to the above. For example, an airline or a trucking firm may use essentially the same model for long-range fleet sizing decisions as for daily fleet routing decision. When solving the long-term fleet sizing decision, the cost of capital should be included in the daily cost of having a vehicle. On the other hand, when making short-run routing decisions, the cost of capital should not be included in the daily cost of a vehicle. However, the number of vehicles used is constrained to be no greater than the fleet size chosen in the long-term plan. Only operating costs that vary with the amount of usage of the vehicle should be included when solving the short-term model.

4.5.2 Joint Products

We say we have joint products or byproducts if a single process produces several products. The key feature is that, if you run the process in question, you unavoidably get some amount of each of the joint products. Some examples are:

Process	Joint Products
Crude oil distillation	gasoline, oil, kerosene, tar
Raw milk processing	whole milk, skim milk, 2%, cream, yogurt
Meat processing	light meat, dark meat, steak, chuck roast
Semi-conductor manufacturing	high speed chips, low speed chips
Mining of precious metal ore	gold, silver, copper
Sales calls	sales of various products in product line

There is a temptation, perhaps even a requirement by taxing authorities, that the cost of the joint process be fully allocated to the output products. The important point is that, for decision-making purposes, this allocation serves no purpose. It should be avoided. The proper way to model a joint product process is to have a separate decision variable for each output product, and a decision variable for the joint production process. Costs and revenues should be applied to their associated decision variables (e.g., the cost of distillation should be associated with the decision variable of how much crude to distill). The fact that, if you want to produce gasoline, then you must incur the cost of distillation is taken care of by the constraints. Let us illustrate with an example.

Joint Cost Example

The Chartreuse Company (CC) raises pumpkins. It costs \$800 to plant, harvest and sort a ton of raw pumpkins. CC has capacity to plant and harvest 150 tons of pumpkins. In spite of CC's best efforts at genetic engineering, harvested pumpkins fall equally into three classes of pumpkins of increasing quality: Good, Premium, and Exquisite. Once sorted, it costs \$100 per ton to get each of the classes ready for market. Alternatively, pumpkins from any class can be discarded at zero additional cost. Prices have dropped recently, so there is concern about whether it is profitable to sell all grades of pumpkins. Current selling prices per ton for the three grades are: \$700, \$1100, and \$2200. How much should be processed and sold of each grade?

A proper model is:

$$\begin{aligned} \text{MAX} &= (700 - 100) * G + (1100 - 100) * P + (2200 - \\ & \quad 100) * E - 800 * R; \\ R &\leq 150; \\ G &\leq .3333333 * R; \\ P &\leq .3333333 * R; \\ E &\leq .3333333 * R; \end{aligned}$$

With solution:

```

Optimal solution found at step:          0
Objective value:                        65000.0
Variable      Value      Reduced Cost
   G          50.00000      0.0000000
   P          50.00000      0.0000000
   E          50.00000      0.0000000
   R         150.00000      0.0000000

   Row      Slack or Surplus      Dual Price
     1          65000.00          1.000000
     2           0.000000          433.3333
     3           0.000000          600.0000
     4           0.000000          1000.000
     5           0.000000          2100.000

```

There is a temptation to allocate the cost of planting, harvesting and sorting, over all three grades to get the model:

```

MAX = ( 700 - 100 - 2400/3) * G + (1100 - 100 -
      2400/3) * P + (2200 - 100 - 2400/3) * E ;
G <= .333333 * 150;
P <= .333333 * 150;
E <= .333333 * 150;

```

Given their (apparent) negative profit contribution in the above model, good pumpkins will not be produced. If we then allocate the planting, harvesting, and sorting costs over just P and E , we get:

```

MAX = (1100 - 100 - 2400/2) * P + (2200 - 100 -
      2400/2) * E;
G <= .333333 * 150;
P <= .333333 * 150;
E <= .333333 * 150;

```

Now, of course, Premium grade is not worth producing. This leaves the Exquisite grade to carry the full cost of planting, harvesting, and sorting, and then we see it is not worth producing. Thus, even though we started with a profitable enterprise, blind use of allocation of joint costs caused us to quit the profitable business. The moral to the story is to not do cost allocation.

4.5.3 Book Value vs. Market Value

A common problem in formulating an optimization model for decisionmaking is what cost should be attached to product that is used from inventory. A typical accounting system will carry a book value for product in inventory. The temptation is to use this readily available number as the cost of using product from inventory. For example, suppose you are a gasoline distributor who bought 10,000 gallons of Regular gasoline last month for \$2.77 per gallon. Due to unforeseen events, this month you still have 5,000 gallons of that Regular gasoline in inventory. Now the market price for Regular gasoline has dropped to \$2.70 per gallon, and you are contemplating your production and market operations for this month. How much should you charge yourself for the use of this Regular in inventory? One person might argue that the purchase is now a sunk cost so we should charge ourselves 0. Others might argue that proper "Accounting" says we should charge the book value, \$2.77/gallon. Which is it? The simple quick answer is that for decision making purposes, book value should always be disregarded, except when required by law for the calculation of taxes. Material in

inventory should be treated as having zero cost, however, you should completely enumerate all possible options of what you can do with this inventory, including selling it on the open market.

It helps to clarify issues by completing all the details for our little example and explicitly defining decision variables for all the possible actions available. You can buy or sell Regular in unlimited amounts this month for \$2.70/gallon, however, it costs you \$0.01/gallon in transportation and transaction costs for any gasoline you buy to get it onto your property. Similarly, for any gasoline you sell, there is a transaction cost of \$0.02 per gallon. What can be done with Regular gasoline? It can be sold directly, or it can be blended in equal proportions with Premium gasoline to produce Midgrade gasoline. You have one customer who is willing to pay \$2.82/gallon of Midgrade delivered to his door for up to 6000 gallons, and a second customer who is willing to pay \$2.80/gallon of Midgrade delivered to his door for up to 8000 gallons. Premium gasoline can be purchased in unlimited amounts for \$2.90/gallon. What should we do with our Regular gasoline: nothing, sell it back to the market, buy some Premium to blend with Regular (perhaps even buying more Regular) to sell to customer 1, to customer 2? Following the ABC's of optimization, step A is to define our decision variables: RB = gallons of additional Regular gasoline bought on the market this month, RS = gallons of Regular directly sold on the market this month, PB = gallons of Premium bought, $MS1$ = gallons of Midgrade sold to customer 1, and $MS2$ = gallons of Midgrade sold to customer 2. Step B, the objective function is to maximize revenues minus costs. Step C is to specify the constraints. The two main constraints are the "Sources Equal Uses" constraints for Regular and Premium. A formulation is given below. Recall that a gallon of Midgrade uses a half gallon of Regular and half gallon of Premium. To make the solution report easier to understand, we have given a [row name] to each constraint.

```
!Maximize revenues - costs;
MAX = (2.70 - .02)*RS + (2.82 - .02)*MS1 + (2.80-.02)*MS2
      - (2.70 + .01)*RB - (2.90 + .01)*PB;
!Sources = uses for Regular and Premium;
[SEQUR] 5000 + RB = RS + .5*(MS1 + MS2);
[SEQUP] PB = .5*(MS1 + MS2);
!Upper limits on amount we can sell;
[UL1] MS1 <= 6000;
[UL2] MS2 <= 8000;
```

Notice there is no explicit charge for Regular in inventory. The book value of \$2.77 appears nowhere in the formulation. Inventory is treated as a sunk cost or free good, however, we have included the option to sell it directly. Thus, using Regular to blend Midgrade must compete with simply selling the Regular directly at the current market price. A solution is:

Variable	Value	Reduced Cost
RS	2000.000	0.000000
MS1	6000.000	0.000000
MS2	0.000	0.015000
RB	0.000	0.030000
PB	3000.000	0.000000

Row	Slack or Surplus	Dual Price
1	13430.000	1.000000
SEQUR	0.000	-2.680000
SEQUP	0.000	-2.910000
UL1	0.000	0.005000

UL2

8000.000

0.000000

Thus, it is more profitable to blend the Regular inventory with Premium to sell it to customer 1 than to sell it directly to the market, however, selling Regular directly back to the market is more profitable than selling to customer 2 blended into Midgrade.

4.6 Common Errors in Formulating Models

When you develop a first formulation of some real problem, the formulation may contain errors or bugs. These errors will fall into the following categories:

- A. Simple typographical errors;
- B. Fundamental errors of formulation;
- C. Errors of approximation.

The first two categories of errors are easy to correct once they are identified. In principle, category *A* errors are easy to identify because they are clerical in nature. In a large model, however, tracking them down may be a difficult search problem. Category *B* errors are more fundamental because they involve a misunderstanding of either the real problem or the nature of LP models. Category *C* errors are subtler. Generally, a model of a real situation involves some approximation (e.g., many products are aggregated together into a single macro-product, the days of a week are lumped together, or costs that are not quite proportional to volume are nevertheless treated as linear). Avoiding category *C* errors requires skill in identifying which approximations can be tolerated.

With regard to category *A* errors, if the user is fortunate, category *A* errors will manifest themselves by causing solutions that are obviously incorrect.

Errors of formulation are more difficult to discuss because they are of many forms. Doing what we call dimensional analysis can frequently expose the kinds of errors made by a novice. Anyone who has taken a physics or chemistry course would know it as “checking your units.” Let us illustrate by considering an example.

A distributor of toys is analyzing his strategy for assembling Tinkertoy sets for the upcoming holiday season. He assembles two kinds of sets. The “Big” set is composed of 60 sticks and 30 connectors, while the “Tot” set is composed of 30 sticks and 20 connectors. An important factor is, for this season, he has a supply of only 60,000 connectors and 93,000 sticks. He will be able to sell all that he assembles of either set. The profit contributions are \$5.5 and \$3.5 per set, respectively, for Big and Tot. How much should he sell of each set to maximize profit?

The distributor developed the following formulation. Define:

- B = number of Big sets to assemble;
- T = number of Tot sets to assemble;
- S = number of sticks actually used;
- C = number of connectors actually used.

$$\begin{aligned} \text{MAX} &= 5.5 * B + 3.5 * T; \\ B - 30 * C - 60 * S &= 0; \\ T - 20 * C - 30 * S &= 0; \\ &C \leq 60000; \\ &S \leq 93000; \end{aligned}$$

Notice the first two constraints are equivalent to:

$$B = 30C + 60S$$

$$T = 20C + 30S$$

Do you agree with the formulation? If so, you should analyze its solution below:

```

Optimal solution found at step:          0
Objective value:                        0.5455500E+08
Variable          Value          Reduced Cost
   B             7380000.          0.0000000
   T             3990000.          0.0000000
   C              60000.00          0.0000000
   S              93000.00          0.0000000
Row      Slack or Surplus      Dual Price
  1             0.5455500E+08          1.0000000
  2             0.0000000            5.5000000
  3             0.0000000            3.5000000
  4             0.0000000            235.00000
  5             0.0000000            435.00000

```

There is a hint that the formulation is incorrect because the solution is able to magically produce almost four million Tot sets from only 100,000 sticks.

The mistake that was made is a very common one for newcomers to LP, namely, trying to describe the features of an activity by a constraint. A constraint can always be thought of as a statement that the usage of some item must be less-than-or-equal-to the sources of the item. The last two constraints have this characteristic, but the first two do not.

If one analyzes the dimensions of the components of the first two constraints, one can see there is trouble. The dimensions (or “units”) for the first constraint are:

Term	Units
B	Big sets
$30C$	$30 \text{ [connectors/(Big set)]} \times \text{connectors}$
$60S$	$60 \text{ [sticks/(Big set)]} \times \text{sticks}$

Clearly, they have different units, but if you are adding items together, they must have the same units. It is elementary that you cannot add apples and oranges. The units of all components of a constraint must be the same.

If one first formulates a problem in words and then converts it to the algebraic form in LINGO, one frequently avoids the above kind of error. In words, we wish to:

```

Maximize profit contribution
Subject to:
    Usage of connectors ≤ sources of connectors
    Usage of sticks ≤ sources of sticks

```

Converted to algebraic form in LINGO, it is:

```

MAX = 5.5 * B + 3.5 * T;
      30 * B + 20 * T <= 60000;
      60 * B + 30 * T <= 93000;

```

The units of the components of the constraint $30B + 20T \leq 60,000$ are:

Term	Units
$30B$	$30 [\text{connectors}/(\text{Big set})] \times (\text{Big set}) = 30 \text{ connectors}$
$20T$	$20 [\text{connectors}/(\text{Tot set})] \times (\text{Tot set}) = 20 \text{ connectors}$
60,000	60,000 connectors available

Thus, all the terms have the same units of “connectors”. Solving the problem, we obtain the sensible solution:

Optimal solution found at step:		0
Objective value:		10550.00
Variable	Value	Reduced Cost
B	200.0000	0.000000
T	2700.000	0.000000
Row	Slack or Surplus	Dual Price
1	10550.00	1.000000
2	0.000000	0.150000
3	0.000000	0.1666667E-01

4.7 The Nonsimultaneity Error

It must be stressed that all the constraints in an LP formulation apply simultaneously. A combination of activity levels must be found that simultaneously satisfies all the constraints. The constraints do not apply in an either/or fashion, although we might like them to be so interpreted. As an example, suppose we denote by B the batch size for a production run of footwear. A reasonable policy might be, if a production run is made, at least two dozen units should be made. Thus, B will be either zero or some number greater-than-or-equal-to 24. There might be a temptation to state this policy by writing the two constraints:

$$B \leq 0$$

$$B \geq 24.$$

The desire is that exactly one of these constraints be satisfied. If these two constraints are part of an LP formulation, the computer will reject such a formulation with a curt remark to the effect that no feasible solution exists. There is no unique value for B that is simultaneously less-than-or-equal-to zero and greater-than-or-equal-to 24.

If such either/or constraints are important, then one must resort to integer programming. Such formulations will be discussed in a later section.

4.8 Problems

1. The Tiny Timber Company wants to utilize best the wood resources in one of its forest regions. Within this region, there is a sawmill and a plywood mill. Thus, timber can be converted to lumber or plywood.

Producing a marketable mix of 1000 board feet of lumber products requires 1000 board feet of spruce and 4000 board feet of Douglas fir. Producing 1000 square feet of plywood requires 2000 board feet of spruce and 4000 board feet of Douglas fir. This region has available 32,000 board feet of spruce and 72,000 board feet of Douglas fir.

Sales commitments require at least 5000 board feet of lumber and 12,000 square feet of plywood be produced during the planning period. The profit contributions are \$45 per 1000 board feet of lumber products and \$60 per 1000 square feet of plywood. Let L be the amount (in 1000 board feet) of lumber produced and let P be the amount (in 1000 square feet) of plywood produced. Express the problem as a linear programming model.

2. Shmuzzles, Inc., is a struggling toy company that hopes to make it big this year. It makes three fundamental toys: the Shmacrobat, the Shlameleon, and the JigSaw Shmuzzle. Shmuzzles is trying to unload its current inventories through airline in-flight magazines by packaging these three toys in two different size kits, the Dilettante Shmuzzler kit and the Advanced Shmuzzler kit. It's \$29.95 for the Dilettante, whereas the Advanced sells for \$39.95. The compositions of these two kits are:

$$\begin{aligned} \text{Dilettante} &= 6 \text{ Shmacrobats plus } 10 \text{ Shlameleons plus } 1 \text{ Jig Saw} \\ \text{Advanced} &= 8 \text{ Shmacrobats plus } 18 \text{ Shlameleons plus } 2 \text{ Jig Saws} \end{aligned}$$

Current inventory levels are: 6,000 Shmacrobats, 15,000 Shlameleons, and 1,500 JigSaws. Formulate a model for helping Shmuzzles, Inc., maximize its profits.

3. A standard problem encountered by many firms when introducing new products is the "phase-out" problem. Given the components for products that are being phased out, the question is: what amounts of the phased out products should be built so as to most profitably use the available inventory. The following illustrates. The R. R. Bean Company produces, packages, and distributes freeze-dried food for the camping and outdoor sportsman market. R. R. Bean is ready to introduce a new line of products based on a new drying technology that produces a higher quality, tastier food. The basic ingredients of the current (about to be discontinued) line are dried fruit, dried meat and dried vegetables. There are two products in the current (to be phased out) line: the "Weekender" and the "ExpeditionPak". In its "close-out" catalog, the selling prices of the two products are \$3.80 and \$7.00 per package, respectively. Handling and shipping costs are \$1.50 per package for each package. It is R. R. Bean's long standing practice to include shipping and handling at no charge. The "Weekender" package consists of 3 ounces of dried fruit, 7 ounces of dried meat, and 2 ounces of dried vegetables. The makeup of the "ExpeditionPak" package is 5 ounces of dried fruit, 18 ounces of dried meat, and 5 ounces of dried vegetables. R. R. Bean would like to deplete, as most profitably as possible, its inventories of "old technology" fruit, meat, and vegetables before introducing the new line. The current inventories are 10,000 ounces, 25,000 ounces, and 12,000 ounces respectively of fruit, meat, and vegetables. The book values of these inventories are \$2000, \$2500, and \$1800. Any leftover inventory will be given to the local animal shelter at no cost or benefit to R. R. Bean. The prices in the catalog are such that R. R. Bean is confident that it can sell all that it makes of the two products. Formulate and solve an LP that

should be useful in telling R.R. Bean how many “Weekender” and “Expedition Pak” packages should be mixed to maximize profits from its current inventories.

4. Quart Industries produces a variety of bottled food products at its various plants. At its Americus plant, it produces two products, peanut butter and apple butter. There are two scarce resources at this plant: packaging capacity and sterilization capacity. Both have a capacity of 40 hours per week. Production of 1000 jars of peanut butter requires 4 hours of sterilizer time and 5 hours of packaging time, whereas it takes 6 hours of sterilizer time and 4 hours of packaging time to produce 1000 jars of apple butter. The profit contributions per 1000 jars for the two products are \$1100 and \$1300, respectively. Apple butter preparation requires a boil-down process best done in batches of at least 5000 jars. Thus, apple butter production during the week should be either 0, or 5000 or more jars. How much should be produced this week of each product?
5. An important skill in model formulation is the ability to enumerate all alternatives. Scott Wilkerson is a scientist-astronaut aboard a seven-day space shuttle mission. In spite of a modest health problem that is aggravated by the zero gravity of space, Scott has been allowed on the mission because of his scientific skills and because a pharmaceutical company has prepared a set of two types of pills for Scott to take each day to alleviate his medical condition. At the beginning of each day Scott is to take exactly one type X pill and exactly one type Y pill. If he deviates from this scheme, it will be life threatening for him and the shuttle will have to be brought down immediately. On the first day of the mission, Scott gets one type X pill out of the X bottle, but in the process of trying to get a pill out of the Y bottle, two come out. He grasps for them immediately with the hand that has the X pill and now he finds he has three pills in his hand. Unfortunately, the X and Y pills are indistinguishable. Both types look exactly like a standard aspirin. There are just enough pills for the full length mission, so none can be discarded. What should Scott do? (Hint: this problem would be inappropriate in the integer programming chapter.)

5

The Sets View of the World

*In Normal form, each attribute/field of an entity/record should depend on the entity key, the whole key, and nothing but the key, so help me Codd.
-anonymous*

5.1 Introduction

The most powerful feature of LINGO is its ability to model large systems. The key concept that provides this power is the idea of a set of similar objects. When you are modeling situations in real life, there will typically be one or more groups of similar objects. Examples of such groups might be factories, products, time periods, customers, vehicles, employees, etc. LINGO allows you to group similar objects together into *sets*. Once the objects in your model are grouped into sets, you can make single statements in LINGO that apply to all members of a set.

A LINGO model of a large system will typically have three sections: 1) a SETS section, 2) a DATA section, and 3) a model equations section. The SETS section describes the data structures to be used for solving a certain class of problems. The DATA section provides the data to “populate” the data structures. The model equations section describes the relationships between the various pieces of data and our decisions.

5.1.1 Why Use Sets?

In most large models, you will need to express a group of several very similar calculations or constraints. LINGO’s ability to handle sets allows you to express such formulae or constraints efficiently.

For example, preparing a warehouse-shipping model for 100 warehouses would be tedious if you had to write each constraint explicitly (e.g., “Warehouse 1 can ship no more than its present inventory, Warehouse 2 can ship no more than its present inventory, Warehouse 3 can ship no more than its present inventory...” and so on). You would prefer to make a single general statement of the form: “Each warehouse can ship no more than its present inventory”.

5.1.2 What Are Sets?

A set is a group of similar objects. A set might be a list of products, trucks, employees, etc. Each member in the set may have one or more characteristics associated with it (e.g., weight, price/unit, or income). We call these characteristics *attributes*. All members of the same set have the same set of attribute types. Attribute values can be known in advance or unknowns for which LINGO solves. For example, each product in a set of products might have an attribute listing its price. Each truck in a set

of trucks might have a hauling capacity attribute. In addition, each employee in a set of employees might have an attribute specifying salary as well as an attribute listing birth date.

5.1.3 Types of Sets

LINGO recognizes two kinds of sets: *primitive* and *derived*. A primitive set is a set composed only of objects that can't be further reduced.

A derived set is defined from one or more other sets using two operations: a) selection (of a subset), and/or b) Cartesian product (sometimes called a "cross" or a "join") of two or more other sets. The key concept is that a derived set *derives* its members from other pre-existing sets. For example, we might have the two primitive sets: *WAREHOUSE* and *CUSTOMER*. We might have the derived set called *SHIPLINK*, which consists of every possible combination of a warehouse and a customer. Although the set *SHIPLINK* is derived solely from primitive sets, it is also possible to build derived sets from other derived sets as well.

5.2 The SETS Section of a Model

In a set-based LINGO model, the first section in the model is usually the *SETS section*. A SETS section begins with the keyword `SETS:` (including the colon) and ends with the keyword `ENDSETS`. A model may have no SETS section, a single SETS section, or multiple SETS sections. A SETS section may appear almost anywhere in a model. The major restriction is that you must define a set and its attributes before they are referenced in the model's constraints.

5.2.1 Defining Primitive Sets

To define a primitive set in a SETS section, you specify:

- ◆ the *name* of the set, and
- ◆ any *attributes* the members of the set may have.

A primitive set definition has the following syntax¹:

```
setname:[attribute_list];
```

The *setname* is a name you choose. It should be a descriptive name that is easy to remember. The set name must conform to standard LINGO naming conventions: begin with an alphabetic character, followed by up to 31 alphanumeric characters or the underscore (`_`). LINGO does not distinguish between upper and lowercase characters in names.

An example sets declaration is:

```
SETS:
    WAREHOUSE: CAPACITY;
ENDSETS
```

This means that we will be working with one or more warehouses. Each one of them has an attribute called *CAPACITY*. Set members may have zero or more *attributes* specified in the *attribute_list* of the set definition. An *attribute* is some property each member of the set possesses. Attribute names must follow standard naming conventions and be separated by commas.

¹The use of Square brackets indicates that a particular item is optional. In this particular case, a primitive set's *member_list* and *attribute_list* are optional.

For illustration, suppose our warehouses had additional attributes related to their location and the number of loading docks. These additional attributes could be added to the attribute list of the set declaration as:

```
WAREHOUSE: CAPACITY, LOCATION, DOCKS;
```

5.2.2 Defining Derived Sets

To define a derived set, you specify:

- ◆ the *name* of the set,
- ◆ its *parent sets*,
- ◆ optionally, any *attributes* the set members may have.

A derived set definition has the following syntax:

```
set_name (parent_set_list) [membership_filter] [: attribute_list];
```

The *set_name* is a standard LINGO name you choose to name the set. The optional *membership_filter* may place a general condition on membership in the set.

The *parent_set_list* is a list of previously defined sets, separated by commas. LINGO constructs all the combinations of members from each of the parent sets to create the members of the derived set. As an example, consider the following SETS section:

```
SETS:
    PRODUCT ;
    MACHINE ;
    WEEK;
    ALLOWED( PRODUCT, MACHINE, WEEK) : VOLUME;
ENDSETS
```

Sets *PRODUCT*, *MACHINE*, and *WEEK* are primitive sets, while *ALLOWED* is derived from parent sets *PRODUCT*, *MACHINE*, and *WEEK*. Unless specified otherwise, the set *ALLOWED* will have one member for every combination of *PRODUCT*, *MACHINE*, and *WEEK*. The attribute *VOLUME* might be used to specify how much of each product is produced on each machine in each week. A derived set that contains all possible combinations of members is referred to as being a *dense* set. When a set declaration includes a *membership_filter* or if the members of the derived set are given explicitly in a DATA section, then we say the set is *sparse*.

Summarizing, a derived set's members may be constructed by either:

- ◆ an explicit member list in a DATA section,
- ◆ a membership filter, or
- ◆ implicitly dense by saying nothing about the membership of the derived set.

Specification of an explicit membership list for a derived set in a DATA section will be illustrated in the next section of the text.

If you have a large, sparse set, explicitly listing all members can become cumbersome. Fortunately, in many sparse sets, the members all satisfy some condition that differentiates them from the non-members. If you can specify this condition, you can save yourself a lot of typing. This is exactly how the membership filter method works. Using the membership filter method of defining a derived set's *member_list* involves specifying a logical condition that each potential set member must satisfy for inclusion in the set. You can look at the logical condition as a *filter* that filters out potential members who don't measure up to some criteria.

As an example of a membership filter, suppose you have already defined a set called *TRUCKS* and each truck has an attribute called *CAPACITY*. You would like to derive a subset from *TRUCKS* that contains only those trucks capable of hauling big loads. You could use an explicit member list and explicitly enter each of the trucks that can carry heavy loads. However, why do all that work when you could use a membership filter as follows:

```
HEAVY_DUTY ( TRUCKS ) | CAPACITY ( &1 ) #GT# 50000;
```

We have named the set *HEAVY_DUTY* and have derived it from the parent set *TRUCKS*. The vertical bar character (|) is used to mark the beginning of a membership filter. The membership filter allows only those trucks that have a hauling capacity (*CAPACITY*(&1)) greater than (#GT#) 50,000 into the *HEAVY_DUTY* set. The &1 symbol in the filter is known as a *set index placeholder*. When building a derived set that uses a membership filter, LINGO generates all the combinations of parent set members. Each combination is then "plugged" into the membership condition to see if it passes the test. The first parent set's value is plugged into &1, the second into &2, and so on. In this example, we have only one parent set (*TRUCKS*), so &2 would not have made sense. The symbol #GT# is a *logical operator* and means "greater than". Other logical operators recognized by LINGO include:

◆ #EQ#	equal
◆ #NE#	not equal
◆ #GE#	greater-than-or-equal-to
◆ #LT#	less than
◆ #LE#	less-than-or-equal-to

5.2.3 Summary

LINGO recognizes two types of sets - *primitive* and *derived*. Primitive sets are the fundamental objects in a model and can't be broken down into smaller components. Derived sets, on the other hand, are created from other component sets. These component sets are referred to as the parents of the derived set and may be either primitive or derived.

A derived set can be either *sparse* or *dense*. Dense sets contain all combinations of the parent set members (sometimes this is also referred to as the *Cartesian product* or *cross* of the parent sets). Sparse sets contain only a subset of the cross of the parent sets. These may be defined by two methods - *explicit listing* or *membership filter*. The explicit listing method involves listing the members of the sparse set in a DATA section. The membership filter method allows you to specify the sparse set members compactly using a logical condition, which all members must satisfy. The relationships amongst the various set types are illustrated in Figure 5.1 below.

Figure 5.1 Types of Sets

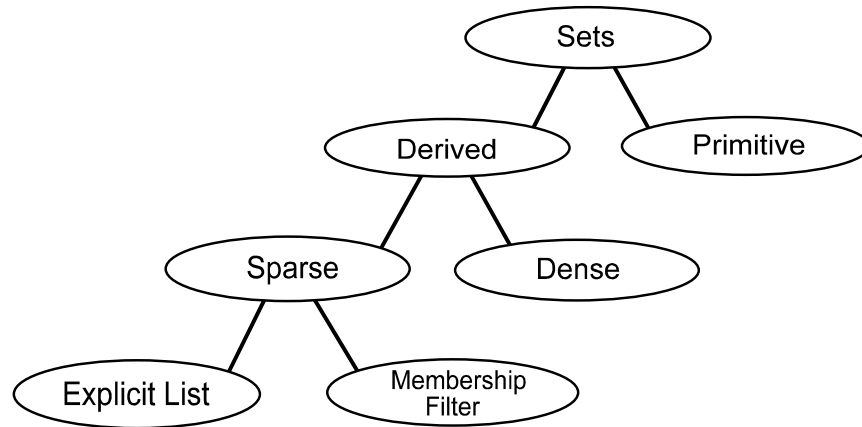

5.3 The DATA Section

A SETS section describes the structure of the data for a particular class of problems. A DATA section provides the data to create a specific instance of this class of problems. The DATA section allows you to isolate things that are likely to change from week to week. This is a useful practice in that it leads to easier model maintenance and makes a model easier to scale up or down in dimension.

We find it useful to partition a LINGO model of a large system into three distinct sections: a) the SETS section, b) the DATA section, and c) the model equations section. The developer of a model has to understand all three sections. However, if the developer has done a good job of partitioning the model into the aforementioned sections, the day-to-day user may only need to be familiar with the DATA section.

Similar to the SETS section, the DATA section begins with the keyword `DATA:` (including the colon) and ends with the keyword `ENDDATA`. In the DATA section, you place statements to initialize either the attributes of the member of a set you defined in a SETS section or even the set members. These expressions have the syntax:

attribute_list = value_list;

or

set_name = member_list;

The *attribute_list* contains the names of the attributes you want to initialize, optionally separated by commas. If there is more than one attribute name on the left-hand side of the statement, then all attributes must be associated with the same set. The *value_list* contains the values you want to assign to the attributes in the *attribute_list*, optionally separated by commas. Consider the following example:

```
SETS:
    SET1: X, Y;
ENDSETS
DATA:
    SET1 = M1, M2, M3;
    X = 1 2 3;
    Y = 4 5 6;
ENDDATA
```

We have two attributes, *X* and *Y*, defined on the set *SET1*. The three values of *X* are set to 1, 2, and 3, while *Y* is set to 4, 5, and 6. We could have also used the following compound data statement to the same end:

```
SETS:
    SET1: X, Y;
ENDSETS
DATA:
    SET1 X Y =
    M1 1 4
    M2 2 5
    M3 3 6;
ENDDATA
```

Looking at this example, you might imagine *X* would be assigned the values 1, 4, and 2, since they are first in the values list, rather than the true values of 1, 2, and 3. When LINGO reads a data statement's value list, it assigns the first *n* values to the first position of each of the *n* attributes in the attribute list, the second *n* values to the second position of each of the *n* attributes, and so on. In other words, LINGO is expecting the input data in column form rather than row form.

The DATA section can also be used for specifying members of a derived set. The following illustrates both how to specify set membership in a DATA section and how to specify a sparse derived set. This example also specifies values for the *VOLUME* attribute, although that is not required:

```
SETS:
    PRODUCT ;
    MACHINE ;
    WEEK ;
    ALLOWED ( PRODUCT, MACHINE, WEEK ) : VOLUME;
ENDSETS
DATA:
    PRODUCT = A B;
    MACHINE = M N;
    WEEK = 1..2;
    ALLOWED, VOLUME =
    A M 1 20.5
    A N 2 31.3
    B N 1 15.8;
ENDDATA
```

The *ALLOWED* set does not have the full complement of eight members. Instead, *ALLOWED* is just the three member sparse set:

$$(A, M, 1), (A, N, 2), \text{ and } (B, N, 1).$$

LINGO recognizes a number of standard sets. For example, if you declare in a DATA section:

```
PRODUCT = 1..5;
```

then the members of the *PRODUCT* set will in fact be 1, 2, 3, 4, and 5. If you declare:

```
PERIOD = Feb..May;
```

then the members of the *PERIOD* set will in fact be Feb, Mar, Apr, and May. Other examples of inferred sets include mon..sun and thing1..thing12.

If an attribute is not referenced in a DATA section, then it is by default a decision variable. LINGO may set such an attribute to whatever value is consistent with the statements in the model equations section.

This section gave you a brief introduction to the use of the DATA section. Data do not have to actually reside in the DATA section as shown in these examples. In fact, a DATA section can have OLE links to Excel, ODBC links to databases, and connections to other spreadsheet and text based data files. Examples are given later in this chapter.

Note, when LINGO constructs the derived set, it is the right-most parent set that is incremented the fastest.

5.4 Set Looping Functions

In the model equations section of a model, we state the relationships among various attributes. Any statements not in a SETS or DATA section are by default in the model equations section. The power of set based modeling comes from the ability to apply an operation to all members of a set using a single statement. The functions in LINGO that allow you to do this are called *set looping functions*. If your models do not make use of one or more set looping functions, you are missing out on the power of set based modeling and, even worse, you're probably working too hard!

Set looping functions allow you to iterate through all the members of a set to perform some operation. There are four set looping functions in LINGO. The names of the functions and their uses are:

Function	Function's Use
@FOR	Used to generate constraints over members of a set.
@SUM	Computes the sum of an expression over all members of a set.
@MIN	Computes the minimum of an expression over all members of a set.
@MAX	Computes the maximum of an expression over all members of a set.

The syntax for a set looping function is:

```
@loop_function ( setname [ ( set_index_list)
[ | conditional_qualifier ] : expression_list );
```

The *@loop_function* symbol corresponds to one of the four set looping functions listed in the table above. The *setname* is the name of the set over which you want to loop. The *set_index_list* is optional and is used to create a list of indices each of which correspond to one of the parent, primitive sets that form the set specified by *setname*. As LINGO loops through the members of the set *setname*, it will set the values of the indices in the *set_index_list* to correspond to the current member of the set *setname*. The *conditional_qualifier* is an optional filter and may be used to limit the scope of the set looping function. When LINGO is looping over each member of *setname*, it evaluates the *conditional_qualifier*. If the *conditional_qualifier* evaluates to true, then the *expression_list* of the *@loop_function* is performed for the set member. Otherwise, it is skipped. The *expression_list* is a list of expressions to be applied to each member of the set *setname*. When using the *@FOR* function, the expression list may contain multiple expressions that are separated by semicolons. These expressions will be added as constraints to the model. When using the remaining three set looping functions (*@SUM*, *@MAX*, and *@MIN*), the expression list must contain only one expression. If the *set_index_list* is omitted, all attributes referenced in the *expression_list* must be defined on the set *setname*.

5.4.1 @SUM Set Looping Function

In this example, we will construct several summation expressions using the *@SUM* function in order to illustrate the features of set looping functions in general and the *@SUM* function in particular.

Consider the model:

```
SETS:
    SET_A : X;
ENDSETS
DATA:
    SET_A = A1 A2 A3 A4 A5;
    X = 5 1 3 4 6;
ENDDATA
X_SUM = @SUM( SET_A( J) : X( J) );
```

LINGO evaluates the *@SUM* function by first initializing an internal accumulator to zero. LINGO then begins looping over the members in *SET_A*. You can think of *J* as a pronoun. The index variable *J* is first set to the first member of *SET_A* (i.e., *A1*) and *X(A1)* is then added to the accumulator. Then *J* is set to the second element and this process continues until all values of *X* have been added to the accumulator. The value of the sum is then stored into the variable *X_SUM*.

Since all the attributes in our expression list (in this case, only *X* appears in the expression list) are defined on the index set (*SET_A*), we could have alternatively written our sum as:

```
X_SUM = @SUM( SET_A: X );
```

In this case, we have dropped the superfluous index set list and the index on *X*. When an expression uses this shorthand, we say the index list is *implied*. Implied index lists are not allowed when attributes in the expression list have different parent sets.

Next, suppose we want to sum the first three elements of the attribute *X*. We can use a conditional qualifier on the set index to accomplish this as follows:

```
X3_SUM = @SUM( SET_A( J) | J #LE# 3: X( J) );
```

The *#LE#* symbol is called a *logical operator*. This operator compares the operand on the left (*J*) with the one on the right (3) and returns *true* if the left operand is less-than-or-equal-to the one on the right. Otherwise, it returns *false*. Therefore, this time, when LINGO computes the sum, it plugs the set

index variable J into the conditional qualifier $J \#LE\# 3$. If the conditional qualifier evaluates to true, $X(J)$ will be added to the sum. The end result is that LINGO sums up the first three terms in X , omitting the fourth and fifth terms, for a total sum of 9.

Before leaving this example, one subtle aspect to note in this last sum expression is the value that the set index J is returning. Note we are comparing the set index variable to the quantity 3 in the conditional qualifier $J \#LE\# 3$. In order for this to be meaningful, J must represent a numeric value. Since a set index is used to loop over set members, one might imagine a set index is merely a placeholder for the current set member. In a sense, this is true. However, what set indexes *really* return is the *index* of the current set member in its parent primitive set. The index returned is *one-based*. In other words, the value 1 is returned when indexing the first set member, 2 when indexing the second, and so on. Given that set indices return a numeric value, they may be used in arithmetic expressions along with other variables in your model.

5.4.2 @MIN and @MAX Set Looping Functions

The @MIN and @MAX functions are used to find the minimum and maximum of an expression over members of a set. Again, consider the model:

```
SETS:
    SET_A : X;
ENDSETS
DATA:
    SET_A = A1 A2 A3 A4 A5;
    X = 5 1 3 4 6;
ENDDATA
```

To find the minimum and maximum values of X , all one need do is add the two expressions:

```
THE_MIN_OF_X = @MIN( SET_A( J) : X( J) );
THE_MAX_OF_X = @MAX( SET_A( J) : X( J) );
```

As with the @SUM example above, we can use an implied index list since the attributes are defined on the index set. Using implied indexing, we can recast our expressions as:

```
THE_MIN_OF_X = @MIN( SET_A : X );
THE_MAX_OF_X = @MAX( SET_A : X );
```

In either case, when we solve this model, LINGO returns the expected minimum and maximum values of X :

Variable	Value
THE_MIN_OF_X	1.000000
THE_MAX_OF_X	6.000000

For illustration purposes, suppose we had just wanted to compute the minimum and maximum values of the first three elements of X . As with the @SUM example, all we need do is add the conditional qualifier $J \#LE\# 3$. We then have:

```
THE_MIN_OF_X_3 = @MIN( SET_A( J) | J #LE# 3 : X( J) );
THE_MAX_OF_X_3 = @MAX( SET_A( J) | J #LE# 3 : X( J) );
```

with solution:

Variable	Value
THE_MIN_OF_X_3	1.000000
THE_MAX_OF_X_3	5.000000

5.4.3 @FOR Set Looping Function

The *@FOR* function is used to generate constraints across members of a set. Whereas scalar based modeling languages require you to explicitly enter each constraint, the *@FOR* function allows you to enter a constraint just once and LINGO does the work of generating an occurrence of the constraint for each of the set members. As such, the *@FOR* statement provides the set based modeler with a very powerful tool.

To illustrate the use of *@FOR*, consider the following:

```
SETS:
    TRUCKS : HAUL;
ENDSETS
DATA:
    TRUCKS = MAC, PETERBILT, FORD, DODGE;
ENDDATA
```

Specifically, we have a primitive set of four trucks with a single attribute titled *HAUL*. If the attribute *HAUL* is used to denote the amount a truck hauls, then we can use the *@FOR* function to limit the amount hauled by each truck to 2,500 pounds with the following expression:

```
@FOR( TRUCKS( T) : HAUL( T) <= 2500);
```

In this case, it might be instructive to view the constraints that LINGO generates from our expression. You can do this by using the *LINGO | Generate* command under Windows or by using the *GENERATE* command on other platforms. Running this command, we find that LINGO generates the following four constraints:

```
    HAUL( MAC) <= 2500;
    HAUL( PETERBILT) <= 2500;
    HAUL( FORD) <= 2500;
    HAUL( DODGE) <= 2500;
```

As we anticipated, LINGO generated one constraint for each truck in the set to limit them to a load of 2,500 pounds.

Here is a model that uses an *@FOR* statement (listed in bold) to compute the reciprocal of any five numbers placed into the *GPM* attribute:

```
SETS:
    OBJECT: GPM, MPG;
ENDSETS
DATA:
    OBJECT = A B C D E;
    GPM = .0303 .03571 .04545 .07142 .10;
ENDDATA
@FOR( OBJECT( I) :
    MPG( I) = 1 / GPM( I)
);
```

Solving this model gives the following values for the reciprocals:

Variable	Value
MPG(A)	33.00330
MPG(B)	28.00336
MPG(C)	22.00220
MPG(D)	14.00168
MPG(E)	10.00000

Since the reciprocal of zero is not defined, we could put a conditional qualifier on our *@FOR* statement that causes us to skip the reciprocal computation whenever a zero is encountered. The following *@FOR* statement accomplishes this:

```
@FOR( OBJECT( I) | GPM( I) #NE# 0 :
    MPG( I) = 1 / GPM( I)
);
```

The conditional qualifier (listed in bold) tests to determine if the *GPM* is not equal (*#NE#*) to zero. If so, the computation proceeds.

This was just a brief introduction to the use of the *@FOR* statement. There will be many additional examples in the sections to follow.

5.4.4 Nested Set Looping Functions

The simple models shown in the previous section use *@FOR* to loop over a single set. In larger models, you may need to loop over a set within another set looping function. When one set looping function is used within the scope of another, we call it *nesting*. LINGO allows nesting.

The following is an example of an *@SUM* loop nested within an *@FOR*:

```
! The demand constraints;
@FOR( VENDORS( J) :
    @SUM( WAREHOUSES( I) : VOLUME( I, J)) = DEMAND( J)
);
```

Specifically, for each vendor, we sum up the shipments going from all the warehouses to that vendor and set the quantity equal to the vendor's demand.

@SUM, *@MAX*, and *@MIN* can be nested within any set looping function. *@FOR* functions, on the other hand, may only be nested within other *@FOR* functions.

5.5 Set Based Modeling Examples

Recall, four types of sets can be created in LINGO:

- ◆ primitive,
- ◆ dense derived,
- ◆ sparse derived - explicit list, and
- ◆ sparse derived - membership filter.

This section will help develop your talents for set based modeling by building and discussing four models. Each of these four models will introduce one of the set types listed above.

5.5.1 Primitive Set Example

The following staff scheduling model illustrates the use of a primitive set. This model may be found in the *SAMPLES* subdirectory off the main LINGO directory under the name *STAFFDEMLNG*.

The Problem

Suppose you run the popular Pluto Dog's hot dog stand that is open seven days a week. You hire employees to work a five-day workweek with two consecutive days off. Each employee receives the same weekly salary. Some days of the week are busier than others and, based on past experience, you know how many workers are required on a given day of the week. In particular, your forecast calls for these staffing requirements:

Day	Mon	Tue	Wed	Thu	Fri	Sat	Sun
Staff Req'd	20	16	13	16	19	14	12

You need to determine how many employees to start on each day of the week in order to minimize the total number of required employees, while still meeting or exceeding staffing requirements each day of the week.

The Formulation

The first question to consider when building a set based model is, "What are the relevant sets and their attributes?". In this model, we have a single primitive set, the days of the week. We will be concerned with two attributes of the *DAYS* set. The first is the number of staff required on each day. The second is the decision variable of the number of staff to start on each day. If we call these attributes *REQUIRED* and *START*, then we might write the SETS section and DATA sections as:

```
SETS:
    DAYS : REQUIRED, START;
ENDSETS
DATA:
    DAYS = MON TUE WED THU FRI SAT SUN;
    REQUIRED = 20 16 13 16 19 14 12;
ENDDATA
```

We are now at the point where we can begin entering the model's mathematical relations (i.e., the objective and constraints). Let's begin by writing the objective: minimize the total number of employees we start during the week. In standard mathematical notation, we might write:

$$\text{Minimize: } \sum_i START_i$$

The equivalent LINGO statement is very similar. Substitute "MIN=" for "Minimize:" and "@SUM(DAYS(I):" for \sum_i and we have:

```
MIN = @SUM( DAYS( I): START( I) );
```

Now, all that's left is to deduce the constraints. There is only one set of constraints in this model. Namely, we must have enough staff on duty each day to meet or exceed staffing requirements. In words, what we want is:

for each day: Staff on duty today \geq Staff required today,

The right-hand side of this expression, *Staff required today*, is given. It is simply the quantity $REQUIRED(I)$. The left-hand side, *Staff on duty today* takes a little thought. Given that all employees are on a five-day on/two day off schedule, the number of employees working today is:

$$\begin{aligned} \text{Number working today} &= \text{Number starting today} + \\ &\text{Number starting 1 day ago} + \text{Number starting 2 days ago} + \\ &\text{Number starting 3 days ago} + \text{Number starting 4 days ago}. \end{aligned}$$

In other words, to compute the number of employees working today, we sum up the number of people starting today plus those starting over the previous four days. The employees starting five and six days back don't count because they are on their days off. Therefore, using mathematical notation, what one might consider doing is adding the constraint:

$$\sum_{i=j-4, j} START_i \geq REQUIRED_j, \text{ for } j \in DAYS$$

Translating into LINGO notation, we can write this as:

```
@FOR( DAYS( J ):
    @SUM( DAYS( I ) | I #LE# 5: START( J - I + 1 )
        >= REQUIRED( J )
    );
```

In words, the LINGO statement says, for each day of the week, the sum of the employees starting over the five-day period beginning four days ago and ending today must be greater-than-or-equal-to the required number of staff for the day. This sounds correct, but there is a slight problem. If we try to solve our model with this constraint, we get the error message:

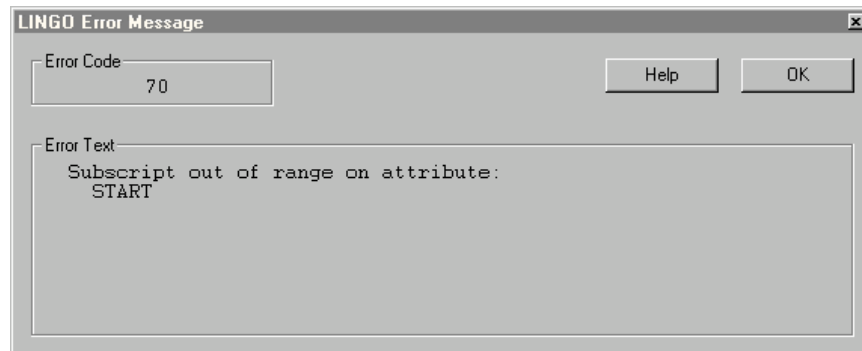

To see why we get this error message, consider what happens on Thursday. Thursday has an index of 4 in our set $DAYS$. As written, the staffing constraint for Thursday will be:

$$\begin{aligned} &START(4 - 1 + 1) + START(4 - 2 + 1) + \\ &START(4 - 3 + 1) + START(4 - 4 + 1) + \\ &START(4 - 5 + 1) \geq REQUIRED(4); \end{aligned}$$

Simplifying, we get:

$$\begin{aligned} &START(4) + START(3) + \\ &START(2) + START(1) + \\ &START(0) \geq REQUIRED(4); \end{aligned}$$

It is the $START(0)$ term that is at the root of our problem. $START$ is defined for days 1 through 7. $START(0)$ does not exist. An index of 0 on $START$ is considered "out of range".

What we would like to do is to have any indices less-than-or-equal-to 0, *wrap around* to the end of the week. Specifically, 0 would correspond to Sunday (7), -1 to Saturday (6), and so on. LINGO has a function that does just this, and it is called $@WRAP$.

The $@WRAP$ function takes two arguments - call them $INDEX$ and $LIMIT$. Formally speaking, $@WRAP$ returns J such that $J = INDEX - K \times LIMIT$, where K is an integer such that J is in the interval $[1, LIMIT]$. Informally speaking, $@WRAP$ will subtract or add $LIMIT$ to $INDEX$ until it falls in the range 1 to $LIMIT$, and, therefore, is just what we need to "wrap around" an index in multi-period planning models.

Incorporating the $@WRAP$ function, we get the corrected, final version of our staffing constraint:

```
@FOR( DAYS( J) :
  @SUM( DAYS( I) | I #LE# 5:
    START( @WRAP( J - I + 1, 7))) >= REQUIRED( J)
  );
```

The Solution

Below is our staffing model in its entirety:

```
SETS:
  DAYS : REQUIRED, START;
ENDSETS
DATA:
  DAYS = MON TUE WED THU FRI SAT SUN;
  REQUIRED = 20 16 13 16 19 14 12;
ENDDATA
MIN = @SUM( DAYS( I): START( I));
@FOR( DAYS( J) :
  @SUM( DAYS( I) | I #LE# 5:
    START( @WRAP( J - I + 1, 7))) >= REQUIRED( J)
  );
```

Solving this model, we get the solution report:

```
Optimal solution found at step:      8
Objective value:                    22.00000

Variable      Value      Reduced Cost
REQUIRED( MON)    20.00000    0.0000000
REQUIRED( TUE)    16.00000    0.0000000
REQUIRED( WED)    13.00000    0.0000000
REQUIRED( THU)    16.00000    0.0000000
REQUIRED( FRI)    19.00000    0.0000000
REQUIRED( SAT)    14.00000    0.0000000
REQUIRED( SUN)    12.00000    0.0000000
START( MON)       8.00000    0.0000000
START( TUE)       2.00000    0.0000000
START( WED)       0.00000    0.0000000
START( THU)       6.00000    0.0000000
START( FRI)       3.00000    0.0000000
START( SAT)       3.00000    0.0000000
START( SUN)       0.00000    0.0000000
```

Row	Slack or Surplus	Dual Price
1	22.000000	1.000000
2	0.0000000	-0.2000000
3	0.0000000	-0.2000000
4	0.0000000	-0.2000000
5	0.0000000	-0.2000000
6	0.0000000	-0.2000000
7	0.0000000	-0.2000000
8	0.0000000	-0.2000000

The objective value of 22 means we need to hire 22 workers.

We start our workers according to the schedule:

	Mon	Tue	Wed	Thu	Fri	Sat	Sun
Start	8	2	0	6	3	3	0

If we look at the surpluses on our staffing requirement rows (rows 2 - 7), we see the slack values are 0 on all of the days. This means there are no extra workers on any day.

5.5.2 Dense Derived Set Example

The following model illustrates the use of a dense derived set in a blending model. This model may be found in the *SAMPLES* subdirectory off the main LINGO directory under the name *CHESS.LNG*.

The Problem

The Chess Snackfoods Co. markets four brands of mixed nuts. The four brands of nuts are called the *Pawn*, *Knight*, *Bishop*, and *King*. Each brand contains a specified ratio of peanuts and cashews. The table below lists the number of ounces of the two nuts contained in each pound of each brand and the price at which the company can sell a pound of each brand:

	Pawn	Knight	Bishop	King
Peanuts (oz.)	15	10	6	2
Cashews (oz.)	1	6	10	14
Selling Price (\$/lb.)	2	3	4	5

Chess has contracts with suppliers to receive per day: 750 pounds of peanuts and 250 pounds of cashews. Our problem is to determine the number of pounds of each brand to produce each day to maximize total revenue without exceeding the available supply of nuts.

The Formulation

The primitive sets in this model are the nut types and the brands of mixed nuts. The *NUTS* set has the single attribute *SUPPLY* that is the daily supply of nuts in pounds. The *BRANDS* set has *PRICE* and *PRODUCE* attributes, where *PRICE* stores the selling price of the brands and *PRODUCE* represents the decision variables of how many pounds of each brand to produce each day.

We need one more set, however, in order to input the brand formulas. We need a two dimensional table defined on the nut types and the brands. To do this, we will generate a derived set from the cross of the *NUTS* and *BRANDS* sets. Adding this derived set, we get the complete SETS section:

```
SETS:
    NUTS : SUPPLY;
    BRANDS : PRICE, PRODUCE;
    FORMULA( NUTS, BRANDS): OUNCES;
ENDSETS
```

We have titled the derived set *FORMULA*, and it has the single attribute *OUNCES*, which will be used to store the ounces of nuts used per pound of each brand. Since we have not specified the members of this derived set, LINGO assumes we want the complete, dense set that includes all pairs of nuts and brands.

Now that our sets are defined, we can move on to building the DATA section. We initialize the three attributes *SUPPLY*, *PRICE*, and *OUNCES* in the DATA section as follows:

```
DATA:
    NUTS = PEANUTS, CASHEWS;
    SUPPLY = 750 250;
    BRANDS = PAWN, KNIGHT, BISHOP, KING;
    PRICE = 2 3 4 5;
    OUNCES = 15 10 6 2 !(Peanuts);
            1 6 10 14; !(Cashews);
ENDDATA
```

With the sets and data specified, we can enter our objective function and constraints. The objective function of maximizing total revenue is straightforward:

```
MAX = @SUM( BRANDS( I): PRICE( I) * PRODUCE( I));
```

Our model has only one class of constraints. Namely, we can't use more nuts than we are supplied with on a daily basis. In words, we would like to ensure that:

For each nut type i, the number of pounds of nut i used must be less-than-or-equal-to the supply of nut i.

We can express this in LINGO as:

```
@FOR( NUTS( I):
    @SUM( BRANDS( J):
        OUNCES( I, J) * PRODUCE( J) / 16) <= SUPPLY( I)
    );
```

We divide the sum on the left-hand side by 16 to convert from ounces to pounds.

The Solution

Our completed nut-blending model is:

```
SETS:
    NUTS : SUPPLY;
    BRANDS : PRICE, PRODUCE;
    FORMULA( NUTS, BRANDS): OUNCES;
ENDSETS
DATA:
    NUTS = PEANUTS, CASHEWS;
    SUPPLY = 750 250;
    BRANDS = PAWN, KNIGHT, BISHOP, KING;
    PRICE = 2 3 4 5;
    OUNCES = 15 10 6 2 !(Peanuts);
             1 6 10 14; !(Cashews);
ENDDATA
MAX = @SUM( BRANDS( I):
    PRICE( I) * PRODUCE( I));
@FOR( NUTS( I):
    @SUM( BRANDS( J):
        OUNCES( I, J) * PRODUCE(J)/16) <= SUPPLY(I)
    );
```

An abbreviated solution report to the model follows:

```
Optimal solution found at step: 0
Objective value: 2692.308
Variable Value Reduced Cost
PRODUCE( PAWN) 769.2308 0.0000000
PRODUCE( KNIGHT) 0.0000000 0.1538461
PRODUCE( BISHOP) 0.0000000 0.7692297E-01
PRODUCE( KING) 230.7692 0.0000000
Row Slack or Surplus Dual Price
1 2692.308 1.000000
2 0.0000000 1.769231
3 0.0000000 5.461538
```

This solution tells us Chess should produce 769.2 pounds of the Pawn mix and 230.8 of the King for total revenue of \$2692.30. The dual prices on the rows indicate Chess should be willing to pay up to \$1.77 for an extra pound of peanuts and \$5.46 for an extra pound of cashews. If, for marketing reasons, Chess decides it must produce at least some of the Knight and Bishop mixes, then the reduced cost figures tell us revenue will decrease by 15.4 cents with the first pound of Knight produced and revenue will decline by 76.9 cents with the first pound of Bishop produced.

5.5.3 Sparse Derived Set Example - Explicit List

In this example, we will introduce the use of a sparse derived set with an explicit listing. When using this method to define a sparse set, we must explicitly list all members of the set. This will usually be some small subset of the dense set resulting from the full Cartesian product of the parent sets.

For our example, we will set up a PERT (*Program Evaluation and Review Technique*) model to determine the *critical path* of tasks in a project involving the roll out of a new product. PERT is a simple, but powerful, technique developed in the 1950s to assist managers in tracking the progress of large projects. Its first official application was to the fleet submarine ballistic missile project, the

so-called Polaris project. According to Craven(2001), PERT was given its name by Admiral William F. Raborn, who played a key role in starting the Polaris project. Raborn had a new bride whose nickname was Pert. In her honor, Raborn directed that the management system that was to monitor the Polaris project be called Pert. In fact, the PERT system proved so successful the Polaris project was completed eighteen months ahead of schedule! PERT is particularly useful at identifying the critical activities within a project, which, if delayed, will delay the project as a whole. These time critical activities are referred to as the critical path of a project. Having such insight into the dynamics of a project goes a long way in guaranteeing it won't get sidetracked and become delayed. PERT, and a closely related technique called CPM (Critical Path Method), continues to be used successfully on a wide range of projects. The formulation for this model is included in the *SAMPLES* subdirectory off the main LINGO directory under the name *PERTD.LNG*.

The Problem

Wireless Widgets is about to launch a new product — the Solar Widget. In order to guarantee the launch will occur on time, WW wants to perform a PERT analysis of the tasks leading up to the launch. Doing so will allow them to identify the critical path of tasks that must be completed on time in order to guarantee the Solar Widget's timely introduction. The tasks that must be accomplished before introduction and their anticipated times for completion are listed in the table below:

Task	Weeks
Finalize Design	10
Forecast Demand	14
Survey Competition	3
Set Prices	3
Schedule Production Run	7
Cost Out	4
Train Salesmen	10

Certain tasks must be completed before others can commence. These precedence relations are shown in Figure 5.2:

Figure 5.2 Product Launch Precedence Relations

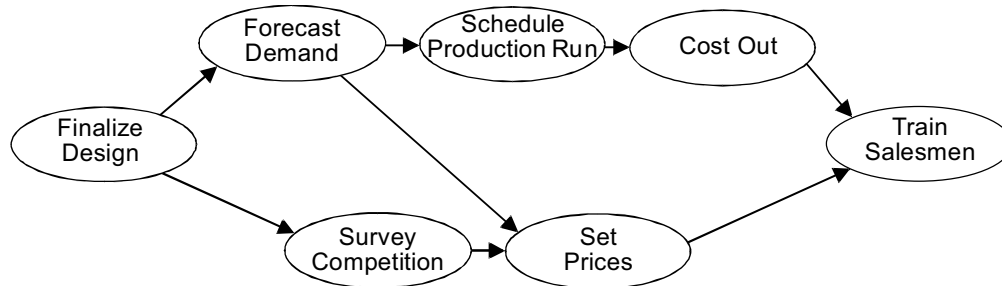

For instance, the two arrows originating from the *Forecast Demand* node indicate the task must be completed before the *Schedule Production Run* and the *Set Prices* tasks may be started.

Our goal is to construct a PERT model for the Solar Widget's introduction in order to identify the tasks on the critical path.

The Formulation

We will need a primitive set to represent the tasks of the project.

We have associated four attributes with the *TASKS* set. The definitions of the attributes are:

TIME	Time duration to complete the task, given
ES	Earliest possible start time for the task, to be computed,
LS	Latest possible start time for the task, to be computed
SLACK	Difference between LS and ES for the task, to be computed.

If a task has a 0 slack, it means the task must start on time or the whole project will be delayed. The collection of tasks with 0 slack time constitutes the critical path for the project.

In order to compute the start times for the tasks, we will need to examine the precedence relations. Thus, we will need to input the precedence relations into the model. The precedence relations can be viewed as a list of ordered pairs of tasks. For instance, the fact the *DESIGN* task must be completed before the *FORECAST* task could be represented as the ordered pair (*DESIGN*, *FORECAST*). Creating a two-dimensional derived set on the *TASKS* set will allow us to input the list of precedence relations. Therefore, our DATA section will look as follows:

```
DATA:
  TASKS : TIME, ES, LS, SLACK;
  PRED( TASKS, TASKS);
```

Notice that the *PRED* set has no attributes. Its purpose is only to provide the information about the precedence relationships between tasks.

Next, we can input the task times and precedence pairs in the DATA section thus:

```
DATA:
  TASKS= DESIGN, FORECAST, SURVEY, PRICE, SCHEDULE, COSTOUT, TRAIN;
  TIME = 10, 14, 3, 3, 7, 4, 10;
  PRED =
    DESIGN, FORECAST,
    DESIGN, SURVEY,
    FORECAST, PRICE,
    FORECAST, SCHEDULE,
    SURVEY, PRICE,
    SCHEDULE, COSTOUT,
    PRICE, TRAIN,
    COSTOUT, TRAIN;
ENDDATA
```

Keep in mind that the first member of the *PRED* set is the ordered pair (*DESIGN*, *FORECAST*) and not just the single task *DESIGN*. Therefore, this set has a total of 8 members. Each of which corresponds to an arc in the precedence relations diagram.

The feature to note from this example is that the set *PRED* is a sparse derived set with an explicit listing of members. The set is a subset derived from the cross of the *TASKS* set upon itself. The set is sparse because it contains only 8 out of a possible 49 members found in the complete cross of *TASKS* on *TASKS*. The set has an explicit listing because we have included a listing of the members we want included in the set. Explicitly listing the members of a sparse set may not be convenient in cases where there are thousands of members to select from, but it does make sense whenever set membership conditions are not well-defined and the sparse set size is small relative to the dense alternative.

Now, with our sets and data established, we can turn our attention to building the formulas of the model. We have three attributes to compute: earliest start (*ES*), latest start (*LS*), and slack time (*SLACK*). The trick is computing *ES* and *LS*. Once we have these times, *SLACK* is merely the difference of the two. Let's start by deriving a formula to compute *ES*. A task cannot begin until all its predecessor tasks are completed. Thus, if we find the latest finishing time of all predecessors to a task, then we have also found its earliest start time. Therefore, in words, the earliest start time for task *t* is equal to the maximum of the sum of the earliest start time of the predecessor plus its completion time over all predecessors of task *t*. The corresponding LINGO notation is:

```
@FOR( TASKS( J) | J #GT# 1:
    ES( J) = @MAX( PRED( I, J): ES( I) + TIME( I));
```

Note, we skip the computation for task 1 by adding the conditional qualifier *J #GT# 1*. We do this because task 1 has no predecessors. We will give the first task an arbitrary start time of 0 below.

Computing *LS* is similar to *ES*, except we must think backwards. In words, the latest time for task *t* to start is the minimum, over all successor tasks *j*, of *j*'s latest start minus the time to perform task *t*. If task *t* starts any later than this, it will force at least one successor to start later than its latest start time. Converting into LINGO syntax gives:

```
@FOR( TASKS( I) | I #LT# LTASK:
    LS( I) = @MIN( PRED( I, J): LS( J) - TIME( I));
```

Here, we omit the computation for the last task, since it has no successor tasks.

Computing slack time is just the difference between *LS* and *ES* and may be written as:

```
@FOR( TASKS( I): SLACK( I) = LS( I) - ES( I));
```

We can set the start time of task 1 to some arbitrary value. For our purposes, we will set it to 0 with the statement:

```
ES( 1) = 0;
```

We have now input formulas for computing the values of all the variables with the exception of the latest start time for the last task. It turns out, if the last project were started any later than its earliest start time, the entire project would be delayed. So, by definition, the latest start time for the last project is equal to its earliest start time. We can express this in LINGO using the equation:

```
LS( 7) = ES( 7);
```

This would work, but it is not a very general way to express the relation. Suppose you were to add some tasks to your model. You'd have to change the 7 in this equation to whatever the new number of tasks was. The whole idea behind LINGO's set based modeling language is the equations in the model should not need changing each time the data change. Expressing the equation in this form violates data independence. Here's a better way to do it:

```
LTASK = @SIZE( TASKS);
LS( LTASK) = ES( LTASK);
```

The *@SIZE* function returns the size of a set. In this case, it will return the value 7, as desired. However, if we changed the number of tasks, *@SIZE* would also return the new, correct value. Thus, we preserve the data independence of our model's structure.

The Solution

The entire PERT formulation and portions of its solution appear below:

```

SETS:
    TASKS : TIME, ES, LS, SLACK;
    PRED( TASKS, TASKS);
ENDSETS
DATA:
    TASKS= DESIGN, FORECAST, SURVEY, PRICE, SCHEDULE, COSTOUT, TRAIN;
    TIME = 10, 14, 3, 3, 7, 4, 10;
    PRED =
        DESIGN, FORECAST,
        DESIGN, SURVEY,
        FORECAST, PRICE,
        FORECAST, SCHEDULE,
        SURVEY, PRICE,
        SCHEDULE, COSTOUT,
        PRICE, TRAIN,
        COSTOUT, TRAIN;
ENDDATA

@FOR( TASKS( J) | J #GT# 1:
    ES( J) = @MAX( PRED( I, J): ES( I) + TIME( I)
    );
@FOR( TASKS( I) | I #LT# LTASK:
    LS( I) = @MIN( PRED( I, J): LS( J) - TIME( I));
    );
@FOR( TASKS( I): SLACK( I) = LS( I) - ES( I));
ES( 1) = 0;
LTASK = @SIZE( TASKS);
LS( LTASK) = ES( LTASK);

```

The interesting part of the solution is:

Variable	Value
LTASK	7.000000
ES(DESIGN)	0.000000
ES(FORECAST)	10.000000
ES(SURVEY)	10.000000
ES(PRICE)	24.000000
ES(SCHEDULE)	24.000000
ES(COSTOUT)	31.000000
ES(TRAIN)	35.000000
LS(DESIGN)	0.000000
LS(FORECAST)	10.000000
LS(SURVEY)	29.000000
LS(PRICE)	32.000000
LS(SCHEDULE)	24.000000
LS(COSTOUT)	31.000000
LS(TRAIN)	35.000000
SLACK(DESIGN)	0.000000
SLACK(FORECAST)	0.000000
SLACK(SURVEY)	19.000000
SLACK(PRICE)	8.000000
SLACK(SCHEDULE)	0.000000

```

SLACK( COSTOUT)      0.000000
SLACK( TRAIN)        0.000000

```

The interesting values are the slacks for the tasks. *SURVEY* and *PRICE* have respective slacks of 19 and 8. The start time of either *SURVEY* or *PRICE* (but not both) may be delayed by as much as these slack values without delaying the completion time of the entire project. The tasks *DESIGN*, *FORECAST*, *SCHEDULE*, *COSTOUT*, and *TRAIN*, on the other hand, have 0 slack. These tasks constitute the critical path. If any of their start times are delayed, the entire project will be delayed. Management will want to pay close attention to these critical path activities to be sure they start on time and complete within the allotted time. Finally, the *ES(TRAIN)* value of 35 tells us the estimated time to the start of the roll out of the new Solar Widget will be 45 weeks: 35 weeks to get to the start of training, plus 10 weeks to complete training.

5.5.4 A Sparse Derived Set Using a Membership Filter

In this example, we introduce the use of a sparse derived set with a membership filter. Using a membership filter is the third method for defining a derived set. When you define a set using this method, you specify a logical condition each member of the set must satisfy. This condition is used to filter out members that don't satisfy the membership condition.

For our example, we will formulate a *matching* problem. In a matching problem, there are N objects we want to match into pairs at minimum cost. Sometimes this is known as the roommate selection problem. It is a problem faced by a university at the beginning of each school year as incoming first year students are assigned to rooms in dormitories. The pair (I, J) is indistinguishable from the pair (J, I) . Therefore, we arbitrarily require I be less than J in the pair. Formally, we require I and J make a set of ordered pairs. In other words, we do not wish to generate redundant ordered pairs of I and J , but only those with I less than J . This requirement that I be less than J will form our membership filter.

The file containing this model may be found in the *SAMPLES* subdirectory off the main LINGO directory under the name *MATCHD.LNG*.

The Problem

Suppose you manage your company's strategic planning department. There are eight analysts in the department. Your department is about to move into a new suite of offices. There are four offices in the new suite and you need to match up your analysts into 4 pairs, so each pair can be assigned to one of the new offices. Based on past observations you know some of the analysts work better together than they do with others. In the interest of departmental peace, you would like to come up with a pairing of analysts that results in minimal potential conflicts. To this goal, you have come up with a rating system for pairing your analysts. The scale runs from 1 to 10, with a 1 rating for a pair meaning the two get along fantastically, whereas all sharp objects should be removed from the pair's office in anticipation of mayhem for a rating of 10. The ratings appear in the following table:

Analysts	1	2	3	4	5	6	7	8
1	-	9	3	4	2	1	5	6
2	-	-	1	7	3	5	2	1
3	-	-	-	4	4	2	9	2
4	-	-	-	-	1	5	5	2
5	-	-	-	-	-	8	7	6
6	-	-	-	-	-	-	2	3
7	-	-	-	-	-	-	-	4

Analysts' Incompatibility Ratings

Since the pairing of analyst I with analyst J is indistinguishable from the pairing of J with I , we have only included the above diagonal elements in the table. Our problem is to find the pairings of analysts that minimizes the sum of the incompatibility ratings of the paired analysts.

The Formulation

The first set of interest in this problem is the set of eight analysts. This primitive set can be written simply as:

```
ANALYSTS;
```

The final set we want to construct is a set consisting of all the potential pairings. This will be a derived set we will build by taking the cross of the *ANALYST* set. As a first pass, we could build the dense derived set:

```
PAIRS ( ANALYSTS, ANALYSTS );
```

This set, however, would include both $PAIRS(I, J)$ and $PAIRS(J, I)$. Since only one of these pairs is required, the second is wasteful. Furthermore, this set will include "pairs" of the same analyst of the form $PAIRS(I, I)$. As much as each of the analysts might like an office of their own, such a solution is not feasible. The solution is to put a membership filter on our derived set requiring each pair (I, J) in the final set to obey the condition J be greater than I . We do this with the set definition:

```
PAIRS ( ANALYSTS, ANALYSTS ) | &2 #GT# &1;
```

The start of the membership filter is denoted with the vertical bar character (`|`). The `&1` and `&2` symbols in the filter are known as *set index placeholders*. Set index placeholders are valid only in membership filters. When LINGO constructs the *PAIRS* set, it generates all combinations in the cross of the *ANALYSTS* set on itself. Each combination is then "plugged" into the membership filter to see if it passes the test. Specifically, for each pair (I, J) in the cross of set *ANALYSTS* on itself, I is substituted

into the placeholder $&I$ and J into $&2$ and the filter is evaluated. If the filter evaluates to true, (I, J) is added to the pairs set. Viewed in tabular form, this leaves us with just the above diagonal elements of the (I, J) pairing table.

We will also be concerned with two attributes of the *PAIRS* set. First, we will need an attribute that corresponds to the incompatibility rating of the pairings. Second, we will need an attribute to indicate if analyst I is paired with analyst J . We will call these attributes *RATING* and *MATCH*. We append them to the *PAIRS* set definition as follows:

```
PAIRS( ANALYSTS, ANALYSTS) | &2 #GT# &1: RATING, MATCH;
```

We will simply initialize the *RATING* attribute to the incompatibility ratings listed in the table above using the *DATA* section:

```
DATA:
  ANALYSTS = 1..8;
  RATING =
    9 3 4 2 1 5 6
    1 7 3 5 2 1
    4 4 2 9 2
    1 5 5 2
    8 7 6
    2 3
    4;
ENDDATA
```

We will use the convention of letting $MATCH(I, J)$ be 1 if we pair analyst I with analyst J , otherwise 0. As such, the *MATCH* attribute contains the decision variables for the model.

Our objective is to minimize the sum of the incompatibility ratings of all the final pairings. This is just the inner product on the *RATING* and *MATCH* attributes and is written as:

```
MIN = @SUM( PAIRS( I, J):
  RATING( I, J) * MATCH( I, J));
```

There is just one class of constraints in the model. In words, what we want to do is:

For each analyst, ensure the analyst is paired with exactly one other analyst.

Putting the constraint into LINGO syntax, we get:

```
@FOR( ANALYSTS( I):
  @SUM( PAIRS( J, K) | J #EQ# I #OR# K #EQ# I:
    MATCH( J, K)) = 1
  );
```

The feature of interest in this constraint is the conditional qualifier $J \#EQ\# I \#OR\# K \#EQ\# I$ on the *@SUM* function. For each analyst I , we sum up all the *MATCH* variables that contain I and set them equal to 1. In so doing, we guarantee analyst I will be paired up with exactly one other analyst. The conditional qualifier guarantees we only sum up the *MATCH* variables that include I in its pairing.

One other feature is required in this model. We are letting $MATCH(I, J)$ be 1 if we are pairing I with J . Otherwise, it will be 0. Unless specified otherwise, LINGO variables can assume any value from 0 to infinity. Since we want *MATCH* to be restricted to being only 0 or 1, we need to add one other feature to our model. What we need is to apply the *@BIN* variable domain function to the *MATCH* attribute. *Variable domain functions* are used to restrict the values a variable can assume. Unlike constraints, variable domain functions do not add equations to a model. The *@BIN* function

restricts a variable to being *binary* (i.e., 0 or 1). When you have a model that contains binary variables, it is said to be an *integer programming* (IP) model. IP models are much more difficult to solve than models that contain only continuous variables. Carelessly formulated IPs (with several hundred integer variables or more) can literally take *forever* to solve! Thus, you should limit the use of binary variables whenever possible. To apply *@BIN* to all the variables in the *MATCH* attribute, add the *@FOR* expression:

```
@FOR( PAIRS( I, J): @BIN( MATCH( I, J)));
```

The Solution

The entire formulation for our matching example and parts of its solution appears below:

```
SETS:
    ANALYSTS;
    PAIRS( ANALYSTS, ANALYSTS) | &2 #GT# &1:
        RATING, MATCH;
ENDSETS
DATA:
    ANALYSTS = 1..8;
    RATING =
        9 3 4 2 1 5 6
         1 7 3 5 2 1
          4 4 2 9 2
           1 5 5 2
            8 7 6
             2 3
              4;
ENDDATA
MIN = @SUM( PAIRS( I, J):
    RATING( I, J) * MATCH( I, J));
@FOR( ANALYSTS( I):
    @SUM( PAIRS( J, K) | J #EQ# I #OR# K #EQ# I:
        MATCH( J, K)) = 1
    );
@FOR( PAIRS( I, J): @BIN( MATCH( I, J)));
```

A solution is:

Variable	Value
MATCH(1, 2)	0.0000000
MATCH(1, 3)	0.0000000
MATCH(1, 4)	0.0000000
MATCH(1, 5)	0.0000000
MATCH(1, 6)	1.0000000
MATCH(1, 7)	0.0000000
MATCH(1, 8)	0.0000000
MATCH(2, 3)	0.0000000
MATCH(2, 4)	0.0000000
MATCH(2, 5)	0.0000000
MATCH(2, 6)	0.0000000
MATCH(2, 7)	1.0000000
MATCH(2, 8)	0.0000000
MATCH(3, 4)	0.0000000
MATCH(3, 5)	0.0000000
MATCH(3, 6)	0.0000000

MATCH (3, 7)	0.0000000
MATCH (3, 8)	1.0000000
MATCH (4, 5)	1.0000000
MATCH (4, 6)	0.0000000
MATCH (4, 7)	0.0000000
MATCH (4, 8)	0.0000000
MATCH (5, 6)	0.0000000
MATCH (5, 7)	0.0000000
MATCH (5, 8)	0.0000000
MATCH (6, 7)	0.0000000
MATCH (6, 8)	0.0000000
MATCH (7, 8)	0.0000000

Notice from the objective value, the total sum of incompatibility ratings for the optimal pairings is 6. Scanning the *Value* column for 1's, we find the optimal pairings: (1,6), (2,7), (3,8), and (4,5).

5.6 Domain Functions for Variables

Variable domain functions were briefly introduced in this chapter when we used *@BIN* in the previous matching model. Variable domain functions allow one to put restrictions on the values allowed for decision variables. Examples of the four domain functions available are:

```
@BIN ( Y);
@GIN ( X);
@BND ( 100, DELIVER, 250);
@FREE ( PROFIT);
```

The statement *@BIN (Y)* restricts the variable *Y* to be a binary variable. That is, it can take on only the values 0 and 1.

The statement *@GIN (X)* restricts the variable *X* to be a general integer variable. That is, it can take on only the values 0, 1, 2, ...

The *@BND ()* specification allows one to specify simple upper and lower bounds. The statement *@BND (100, DELIVER, 250)* restricts the variable *DELIVER* to be in the interval [100, 250]. The same effect could be achieved by the slightly more verbose:

```
DELIVER >= 100;
DELIVER <= 250;
```

LINGO, by default, gives a lower bound of zero to every decision variable. The statement *@FREE (PROFIT)* overrides this default lower bound for the variable *PROFIT* and says that (unfortunately) *PROFIT* can take on any value between minus infinity and plus infinity. Each of the domain functions can appear inside *@FOR* loops, just like any other constraint.

5.7 Spreadsheets and LINGO

In this chapter, we have seen how LINGO can be useful for modeling very large problems. The most widely used method for modeling of any sort is undoubtedly spreadsheet models. When is which approach more appropriate?

The major advantages of doing a model in a spreadsheet are:

- Excellent report formatting features available,
- Large audience of people who understand spreadsheets, and
- Good interface capability with other systems such as word processors.

The major advantages of doing a model in LINGO are:

- Flexibility of various kinds.
- Scalability--It is easy to change the size of any set (e.g., add time periods, products, customers, suppliers, transportation modes, etc.) without having to worry about copying or editing formulae. There is no upper limit of 255(as in a spreadsheet) on the number of columns, or 65536 on the number of rows. There is no limit of about 900(as in a spreadsheet) characters in a formula.
- Sparse sets are easily represented.
- Auditability and visibility--It is easy to see the formulae of a LINGO model in complete, comprehensive form. Truly understanding the model formulae underlying a complex spreadsheet is an exercise in detective work.
- Multiple dimensions are easily represented. A spreadsheet handles two dimensions very well, three dimensions somewhat well, and four or more dimensions not very well.

One can get most of the benefits of both by using LINGO in conjunction with spreadsheets. One can place "hooks" in a LINGO model, so it automatically retrieves and inserts data from/to spreadsheets, databases, and ordinary files. Under Microsoft Windows, the hooks used are the OLE (Object Linking and Embedding) and ODBC (Open Database Connectivity) interfaces provided as part of Windows. Using the OLE capability to connect an Excel spreadsheet to a LINGO model requires two steps:

- a) In the spreadsheet, each data area that is to be either a supplier to or a receiver of data from the LINGO model must be given an appropriate range name. This is done in the spreadsheet by highlighting the area of interest with the mouse, and then using the *Insert | Name | Define* command. The most convenient name to give to a range is the same name by which the data are referenced in the LINGO model.
- b) In the LINGO model, each attribute (vector) (e.g., plant capacities) that is to be retrieved from a spreadsheet, must appear in a LINGO DATA section in a statement of the form:

$$CAPACITY = @OLE('C:\MYDATA.XLS');$$

Each attribute (e.g., amount to ship) to be sent to a spreadsheet must appear in a LINGO DATA section in a statement of the form:

$$@OLE('C:\MYDATA.XLS') = AMT_SHIPPED;$$

If only one spreadsheet is open in Excel, this connection can be simplified. You need only write:

$$CAPACITY = @OLE();$$

LINGO will look in the only open spreadsheet for the range called CAPACITY. This "unspecified spreadsheet" feature is very handy if you want to apply the same LINGO model to several different spreadsheet data sets.

This spreadsheet connection can be pushed even further by embedding the LINGO model in the spreadsheet for which it has a data connection. This is handy because the associated LINGO model will always be obviously and immediately available when the spreadsheet is opened. The screen shot below shows a transportation model embedded in a spreadsheet. To the casual user, it looks like a standard spreadsheet with a special solve button.

The screenshot shows a Microsoft Excel spreadsheet titled "xlingtran" with the following data:

Transportation LP Using Excel and LINGO							
The cost matrix							
	Capacity	CustA	CustB	CustC	CustD		
Demand:		4	7	5	3		
Wh1	10	2	6	4	3	Solve	
Wh2	15	6	6	3	6		
Wh3	11	5	3	4	5		
TotCost=	53	Recommended Shipments				0	0 is OK, else see lingo.log
Wh1		4	0	0	3		
Wh2		0	0	5	0		
Wh3		0	7	0	0		

The spreadsheet also features a "Solve" button in cell G6 and a status bar at the bottom indicating "Ready". The taskbar shows the "LINGO - LINGO Model..." window and the "xlingtran" spreadsheet window.

The data and results are stored on the first tab/sheet of the spreadsheet file. Not so obvious is the LINGO model that is stored on another tab in the same spreadsheet (see below). Completely hidden is a small VBA program in the spreadsheet that causes the LINGO model on the second tab to be solved whenever the Solve button is clicked on the first tab. The complete example can be found in the file xlingtran.xls.

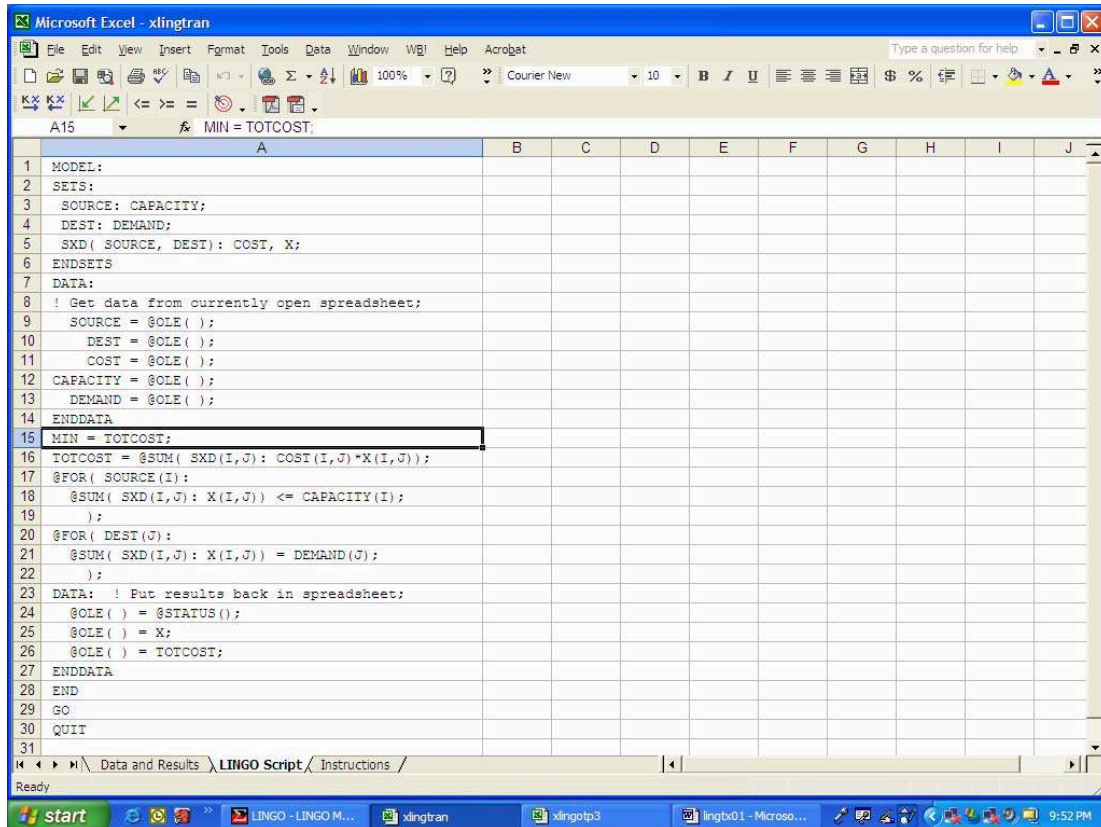

```

Microsoft Excel - xlingtran
File Edit View Insert Format Tools Data Window Web Help Acrobat
Type a question for help
A15 MIN = TOTCOST;
1 MODEL:
2 SETS:
3 SOURCE: CAPACITY;
4 DEST: DEMAND;
5 SXD(SOURCE, DEST): COST, X;
6 ENDSETS
7 DATA:
8 ! Get data from currently open spreadsheet;
9 SOURCE = @OLE();
10 DEST = @OLE();
11 COST = @OLE();
12 CAPACITY = @OLE();
13 DEMAND = @OLE();
14 ENDDATA
15 MIN = TOTCOST;
16 TOTCOST = @SUM(SXD(I,J): COST(I,J)*X(I,J));
17 @FOR(SOURCE(I):
18 @SUM(SXD(I,J): X(I,J)) <= CAPACITY(I);
19 );
20 @FOR(DEST(J):
21 @SUM(SXD(I,J): X(I,J)) = DEMAND(J);
22 );
23 DATA: ! Put results back in spreadsheet;
24 @OLE() = @STATUS();
25 @OLE() = X;
26 @OLE() = TOTCOST;
27 ENDDATA
28 END
29 GO
30 QUIT
31
M:\Data and Results \LINGO Script\ Instructions /
Ready

```

Just as `@OLE()` is used to connect a LINGO model to a spreadsheet and `@ODBC()` is used to connect a LINGO model to most databases that support the SQL interface, the `@TEXT()` statement is available to connect a LINGO model to a simple text file. You can send the value(s) of attribute X to a file called "myfile.out" with:

```

DATA:
  @TEXT('MYFILE.OUT') = X;
ENDDATA

```

The following will send the value of X to the screen, along with an explanatory message:

```
@TEXT() = 'The value of X=', X;
```

Still one more way that LINGO can be incorporated into an application is by way of a subroutine call. A regular computer program, say in C/C++ or Visual Basic, can make a regular call to the LINGO DLL(Dynamic Link Library). The model is passed as a string variable to the LINGO DLL. See the LINGO manual for more details.

5.8 Summary

In this chapter, we've discussed the concept of sets, defined sets, and demonstrated the power and flexibility of set-based modeling. You should now have a foundation of knowledge in the definition and use of both primitive and derived sets.

5.9 Problems

1. You wish to represent the status of an academic institution during a specific teaching term. The major features to be represented are that instructors teach courses and students are registered for courses. You want to keep track of who is teaching which course, who is registered for each course, and which courses a given student is taking. What sets would you recommend if each course is taught by exactly one instructor?
2. Suppose we take into account the additional complication of team teaching. That is, two or more instructors teach some courses. How would you modify your answer to the previous question?

6

Product Mix Problems

6.1 Introduction

Product mix problems are conceptually the easiest constrained optimization problems to comprehend. The Astro/Cosmo problem considered earlier is an example. Although product mix problems are seldom encountered in their simple textbook form in practice, they very frequently constitute important components of larger problems such as multiperiod planning models.

The features of a product mix problem are that there is a collection of products competing for a finite set of resources. If there are m resources and n products, then the so-called “technology” is characterized by a table with m rows and n columns of technologic coefficients. The coefficient in row i , column j , is the number of units of resource i used by each unit of product j . The numbers in a row of the table are simply the coefficients of a constraint in the LP. In simple product mix problems, these coefficients are nonnegative. Additionally, associated with each product is a profit contribution per unit and associated with each resource is an availability. The objective is to find how much to produce of each product (i.e., the mix) to maximize profits subject to not using more of each resource than is available.

The following product mix example will illustrate not only product mix LP formulations, but also: 1) representation of nonlinear profit functions and 2) the fact that most problems have alternative correct formulations. Two people may develop different formulations of the same problem, but both may be correct.

6.2 Example

A certain plant can manufacture five different products in any combination. Each product requires time on each of three machines in the following manner (figures in minutes/unit):

Product	Machine		
	1	2	3
A	12	8	5
B	7	9	10
C	8	4	7
D	10	0	3
E	7	11	2

Each machine is available 128 hours per week.

Products *A*, *B*, and *C* are purely competitive and any amounts made may be sold at respective prices of \$5, \$4, and \$5. The first 20 units of *D* and *E* produced per week can be sold at \$4 each, but all made in excess of 20 can only be sold at \$3 each. Variable labor costs are \$4 per hour for machines 1 and 2, while machine 3 labor costs \$3 per hour. Material costs are \$2 for products *A* and *C*, while products *B*, *D*, and *E* only cost \$1. You wish to maximize profit to the firm.

The principal complication is that the profit contributions of products *D* and *E* are not linear. You may find the following device useful for eliminating this complication. Define two additional products D_2 and E_2 , which sell for \$3 per unit. What upper limits must then be placed on the sale of the original products *D* and *E*? The decision variables and their profit contributions are as follows:

Decision Variables	Definition	Profit Contribution per Unit
<i>A</i>	Number of units of <i>A</i> produced per week	$5 - 2 = \$3$
<i>B</i>	Number of units of <i>B</i> produced per week	$4 - 1 = \$3$
<i>C</i>	Number of units of <i>C</i> produced per week	$5 - 2 = \$3$
<i>D</i>	Number of units of <i>D</i> not in excess of 20 produced/week	\$3
D_2	Number of units of <i>D</i> produced in excess of 20 per week*	\$2
<i>E</i>	Number of units of <i>E</i> not in excess of 20 produced/week	\$3
E_2	Number of units of <i>E</i> produced in excess of 20	\$2
M_1	Hours of machine 1 used per week	-\$4
M_2	Hours of machine 2 used per week	-\$4
M_3	Hours of machine 3 used per week	-\$3

*Total production of product *D* is $D + D_2$.

We will not worry about issues of sequencing the various products on each machine. This is reasonable if the due-dates for the products are far enough in the future. Our problem in this case is to:

Maximize Revenues minus costs
 Subject to
 Minutes used equals minutes run on each machine,
 At most 20 units each can be produced of products *D* and *E*,
 Each machine can be run at most 128 hours.

More precisely, the formulation in LINGO is:

```
! Maximize revenue minus costs;
MAX = 3 * A + 3 * B + 3 * C + 3 * D + 2 * D2 + 3 * E
      + 2 * E2 - 4 * M1 - 4 * M2 - 3 * M3;
! Machine time used = machine time made available;
12*A + 7*B + 8*C + 10*D + 10*D2 + 7*E + 7*E2 - 60*M1 = 0;
8*A + 9*B + 4*C + 11*E + 11*E2 - 60*M2 = 0;
5*A + 10*B + 7*C + 3*D + 3*D2 + 2*E + 2*E2 - 60*M3=0;
D <= 20; ! Max sellable at high price;
E <= 20;
!Machine availability;
M1 <= 128;
M2 <= 128;
M3 <= 128;
END
```

The first three constraints have the units of “minutes” and specify the hours of machine time as a function of the number of units produced. The next two constraints place upper limits on the number of high profit units of *D* and *E* that may be sold. The final three constraints put upper limits on the amount of machine time that may be used and have the units of “hours”.

Constraint 2 can be first written as:

$$\frac{12A + 7B + 8C + 10D + 10D_2 + 7E + 7E_2}{60} = M_1$$

Multiplying by 60 and bringing M_1 to the left gives the second constraint. The solution is:

```
Optimal solution found at step:      4
Objective value:                    1777.625
Variable      Value      Reduced Cost
A             0.0000000    1.358334
B             0.0000000    0.1854168
C             942.5000    0.0000000
D             0.0000000    0.1291668
D2            0.0000000    1.129167
E             20.00000    0.0000000
E2            0.0000000    0.9187501
M1            128.0000    0.0000000
M2            66.50000    0.0000000
M3            110.6250    0.0000000
```

Row	Slack or Surplus	Dual Price
1	1777.625	1.000000
2	0.0000000	0.2979167
3	0.0000000	0.6666667E-01
4	0.0000000	0.5000000E-01
5	20.00000	0.0000000
6	0.0000000	0.8125000E-01
7	0.0000000	13.87500
8	61.50000	0.0000000
9	17.37500	0.0000000

The form of the solution is quite simple to state: make as many of E as possible (20). After that, make as much of product C as possible until we run out of capacity on machine 1.

This problem is a good example of one for which it is very easy to develop alternative formulations of the same problem. These alternative formulations are all correct, but may have more or less constraints and variables. For example, the constraint:

$$8A + 9B + 4C + 11E + 11E_2 - 60M_2 = 0$$

can be rewritten as:

$$M_2 = (8A + 9B + 4C + 11E + 11E_2)/60.$$

The expression on the right-hand side can be substituted for M_2 wherever M_2 appears in the formulation. Because the expression on the right-hand side will always be nonnegative, the nonnegativity constraint on M_2 will automatically be satisfied. Thus, M_2 and the above constraint can be eliminated from the problem if we are willing to do a bit of arithmetic. When similar arguments are applied to M_1 and M_3 and the implied divisions are performed, one obtains the formulation:

```

MAX = 1.416667*A + 1.433333*B + 1.85*C + 2.183334*D + 1.183333*D2 +
1.7*E + .7*E2;
! Machine time used = machine time made available;
12*A + 7*B + 8*C + 10*D + 10*D2 + 7*E + 7*E2 <= 7680;
8*A + 9*B + 4*C + 11*E + 11*E2 <= 7680;
5*A + 10*B + 7*C + 3*D + 3*D2 + 2*E + 2*E2 <= 7680;
! Product limits;
D < 20;
E < 20;

```

This looks more like a standard product mix formulation. All the constraints are capacity constraints of some sort. Notice the solution to this formulation is really the same as the previous formulation:

```

Optimal solution found at step:      6
Objective value:                    1777.625
Variable      Value      Reduced Cost
  A      0.0000000      1.358333
  B      0.0000000      0.1854170
  C      942.5000      0.0000000
  D      0.0000000      0.1291660
  D2     0.0000000      1.129167
  E      20.00000      0.0000000
  E2     0.0000000      0.9187500
Row    Slack or Surplus    Dual Price
  1      1777.625      1.0000000
  2      0.0000000      0.2312500
  3      3690.000      0.0000000
  4      1042.500      0.0000000
  5      20.00000      0.0000000
  6      0.0000000      0.8125000E-01

```

The lazy formulator might give the first formulation, whereas the second formulation might be given by the person who enjoys doing arithmetic.

6.3 Process Selection Product Mix Problems

A not uncommon feature of product mix models is two or more distinct variables in the LP formulation may actually correspond to alternate methods for producing the same product. In this case, the LP is being used not only to discover how much should be produced of a product, but also to select the best process for producing each product.

A second feature that usually appears with product mix problems is a requirement that a certain amount of a product be produced. This condition takes the problem out of the realm of simple product mix. Nevertheless, let us consider a problem with the above two features.

The American Metal Fabricating Company (AMFC) produces various products from steel bars. One of the initial steps is a shaping operation performed by rolling machines. There are three machines available for this purpose, the B_3 , B_4 , and B_5 . The following table gives their features:

Machine	Speed in Feet per Minute	Allowable Raw Material Thickness in Inches	Available Hours per Week	Labor Cost Per Hour Operating
B_3	150	3/16 to 3/8	35	\$10
B_4	100	5/16 to 1/2	35	\$15
B_5	75	3/8 to 3/4	35	\$17

This kind of combination of capabilities is not uncommon. That is, machines that process larger material operate at slower speed.

This week, three products must be produced. AMFC must produce at least 218,000 feet of $\frac{1}{4}$ " material, 114,000 feet of $\frac{3}{8}$ " material, and 111,000 feet of $\frac{1}{2}$ " material. The profit contributions per foot excluding labor for these three products are 0.017, 0.019, and 0.02. These prices apply to all production (e.g., any in excess of the required production). The shipping department has a capacity limit of 600,000 feet per week, regardless of the thickness.

What are the decision variables and constraints for this problem? The decision variables require some thought. There is only one way of producing $\frac{1}{4}$ " material, three ways of producing $\frac{3}{8}$ ", and two ways of producing $\frac{1}{2}$ ". Thus, you will want to have at least the following decision variables. For numerical convenience, we measure length in thousands of feet:

B_{34} = 1,000's of feet of $\frac{1}{4}$ " produced on B_3 ,

B_{38} = 1,000's of feet of $\frac{3}{8}$ " produced on B_3 ,

B_{48} = 1,000's of feet of $\frac{3}{8}$ " produced on B_4 ,

B_{58} = 1,000's of feet of $\frac{3}{8}$ " produced on B_5 ,

B_{42} = 1,000's of feet of $\frac{1}{2}$ " produced on B_4 ,

B_{52} = 1,000's of feet of $\frac{1}{2}$ " produced on B_5 .

For the objective function, we must have the profit contribution including labor costs. When this is done, we obtain:

Variable	Profit Contribution per Foot
B_{34}	0.01589
B_{38}	0.01789
B_{48}	0.01650
B_{58}	0.01522
B_{42}	0.01750
B_{52}	0.01622

Clearly, there will be four constraints corresponding to AMFC's three scarce machine resources and its shipping department capacity. There should be three more constraints due to the production requirements in the three products. For the machine capacity constraints, we want the number of hours required for 1,000 feet processed. For machine B_3 , this figure is $1,000/(60 \text{ min./hr.}) \times (150 \text{ ft./min.}) = 0.111111$ hours per 1,000 ft. Similar figures for B_4 and B_5 are 0.16667 hours per 1,000 ft. and 0.22222 hours per 1,000 feet.

The formulation can now be written:

$$\text{Maximize} = 15.89B_{34} + 17.89B_{38} + 16.5B_{48} + 15.22B_{58} + 17.5B_{42} + 16.22B_{52}$$

subject to

$$0.11111B_{34} + 0.11111B_{38} \leq 35 \quad \text{Machine}$$

$$0.16667B_{48} + 0.16667B_{42} \leq 35 \quad \text{capacities}$$

$$0.22222B_{58} + 0.22222B_{52} \leq 35 \quad \text{in hours}$$

$$B_{34} + B_{38} + B_{48} + B_{58} + B_{42} + B_{52} \leq 600 \quad \text{Shipping capacity in 1,000's of feet}$$

$$B_{34} \geq 218 \quad \text{Production}$$

$$B_{38} + B_{48} + B_{58} \geq 114 \quad \text{requirements}$$

$$B_{42} + B_{52} \geq 111 \quad \text{in 1,000's of feet}$$

Without the last three constraints, the problem is a simple product mix problem.

It is a worthwhile exercise to attempt to deduce the optimal solution just from cost arguments. The $\frac{1}{4}$ " product can be produced on only machine B_3 , so we know B_{34} is at least 218. The $\frac{3}{8}$ " product is more profitable than the $\frac{1}{4}$ " on machine B_3 . Therefore, we can conclude that $B_{34} = 218$ and B_{38} will take up the slack. The $\frac{1}{2}$ " and the $\frac{3}{8}$ " product can be produced on either B_4 or B_5 . In either case, the $\frac{1}{2}$ " is more profitable per foot, so we know B_{48} and B_{58} will be no greater than absolutely necessary. The question is: What is "absolutely necessary"? The $\frac{3}{8}$ " is more profitably run on B_3 than on B_4 or B_5 . Therefore, it follows that we will satisfy the $\frac{3}{8}$ " demand from B_3 and, if sufficient, the remainder from B_4 and then from B_5 . Specifically, we proceed as follows:

$$\text{Set } B_{34} = 218.$$

This leaves a slack of $35 - 218 \times 0.11111 = 10.78$ hours on B_3 . This is sufficient to produce 97,000 feet of $\frac{3}{8}$ ", so we conclude that:

$$B_{38} = 97.$$

The remainder of the $\frac{3}{8}$ " demand must be made up from either machine B_4 or B_5 . It would appear that it should be done on machine B_4 because the profit contribution for $\frac{3}{8}$ " is higher on B_4 than B_5 . Note, however, that $\frac{1}{2}$ " is also more profitable on B_4 than B_5 by exactly the same amount. Thus, we are indifferent. Let us arbitrarily use machine B_4 to fill the rest of $\frac{3}{8}$ " demand. Thus:

$$B_{48} = 17.$$

Now, any remaining capacity will be used to produce $\frac{1}{2}$ " product. There are $35 - 17 \times 0.16667 = 32.16667$ hours of capacity on B_4 . At this point, we should worry about shipping capacity. We still have capacity for $600 - 218 - 97 - 17 = 268$ in 1,000's of feet. B_{42} is more profitable than B_{52} , so we will make it as large as possible. Namely, $32.16667/0.16667 = 193$, so:

$$B_{42} = 193.$$

The remaining shipping capacity is $268 - 193 = 75$, so:

$$B_{52} = 75.$$

Any LP is in theory solvable by similar manual economic arguments, but the calculations could be very tedious and prone to errors of both arithmetic and logic. If we take the lazy route and solve it with LINGO, we get the same solution as our manual one:

Optimal solution found at step: 2
 Objective value: 10073.85

Variable	Value	Reduced Cost
B34	218.00000	0.000000
B38	97.00315	0.000000
B48	16.99685	0.000000
B58	0.00000	0.000000
B42	192.99900	0.000000
B52	75.00105	0.000000

Row	Slack or Surplus	Dual Price
1	10073.85	1.000000
2	0.000000	24.030240
3	0.000000	7.679846
4	18.333270	0.000000
5	0.000000	16.220000
6	0.000000	-3.000000
7	0.000000	-1.000000
8	157.000000	0.000000

Ranges in which the basis is unchanged:

Variable	Objective Coefficient Ranges		
	Current Coefficient	Allowable Increase	Allowable Decrease
B34	15.89000	3.000000	INFINITY
B38	17.89000	INFINITY	2.670000
B48	16.50000	1.000000	0.0
B58	15.22000	0.000000	INFINITY
B42	17.50000	0.0	1.000000
B52	16.22000	1.280000	0.0

Row	Right-hand Side Ranges		
	Current RHS	Allowable Increase	Allowable Decrease
2	35.00000	1.888520	9.166634
3	35.00000	12.50043	13.75036
4	35.00000	INFINITY	18.33327
5	600.0000	82.50053	75.00105
6	218.0000	97.00315	16.99685
7	114.0000	157.0000	16.99685
8	111.0000	157.0000	INFINITY

Notice *B58* is zero, but its reduced cost is also zero. This means *B58* could be increased (and *B48* decreased) without affecting profits. This is consistent with our earlier statement that we were indifferent between using *B48* and *B58* to satisfy the $\frac{3}{8}$ " demand.

Below is a sets version of the problem:

```

!This is a sets version of the previous example;
MODEL:
SETS:
    MACHINE / B3, B4, B5 / : HPERWK, TIME;
!This is the coefficient for the time per day constraint;
    THICKNESS / FOURTH, EIGHT, HALF / : NEED;
!This is the amount of each thickness needed
to be produced;
    METHOD ( MACHINE, THICKNESS ) : VOLUME, PROFIT, POSSIBLE;
!VOLUME is the variable, PROFIT the objective coefficients, and
POSSIBLE is a Boolean representing whether it is possible to produce
the given thickness;
ENDSETS
DATA:
! Hours/week available on each machine;
    HPERWK = 35, 35, 35;
! Hours per 1000 feet for each machine;
    TIME = .11111 .16667 .22222;
! Amount needed of each product;
    NEED = 218 114 111;
! Profit by product and machine;
    PROFIT = 15.89, 17.89, 0,
             0, 16.5, 17.5,
             0, 15.22, 16.22;
! Which products can be made on which machine;
    POSSIBLE = 1, 1, 0,
              0, 1, 1,
              0, 1, 1;
! Shipping capacity per day;
    SHPERDAY = 600;
ENDDATA
!-----;
!Objective function;
MAX = @SUM( METHOD(I,J): VOLUME(I,J) * PROFIT(I,J));
@SUM( METHOD( K, L): VOLUME( K, L)) <= SHPERDAY;
!This is the max amount that can be made each day;
@FOR( MACHINE( N):
! Maximum time each machine can be used/week.;
@SUM( THICKNESS( M):
POSSIBLE(N,M) * VOLUME(N,M) * TIME(N)) <= HPERWK(N););
@FOR( THICKNESS( Q) :
!Must meet demand for each thickness;
@SUM( MACHINE(P): POSSIBLE(P,Q)*VOLUME(P,Q)) >= NEED(Q));
END

```

6.4 Problems

1. Consider a manufacturer that produces two products, Widgets and Frisbees. Each product is made from the two raw materials, polyester and polypropylene. The following table gives the amounts required of each of the two products:

Widgets	Frisbees	Raw Material
3	5	Polyester
6	2	Polypropylene

Because of import quotas, the company is able to obtain only 12 units and 10 units of polyester and polypropylene, respectively, this month. The company is interested in planning its production for the next month. For this purpose, it is important to know the profit contribution of each product. These contributions have been found to be \$3 and \$4 for Widgets and Frisbees, respectively. What should be the amounts of Widgets and Frisbees produced next month?

2. The Otto Maddick Machine Tool Company produces two products, muffler bearings and torque amplifiers. One muffler bearing requires $\frac{1}{8}$ hour of assembly labor, 0.25 hours in the stamping department, and 9 square feet of sheet steel. Each torque amplifier requires $\frac{1}{3}$ hour in both assembly and stamping and uses 6 square feet of sheet steel. Current weekly capacities in the two departments are 400 hours of assembly labor and 350 hours of stamping capacity. Sheet steel costs 15 cents per square foot. Muffler bearings can be sold for \$8 each. Torque amplifiers can be sold for \$7 each. Unused capacity in either department cannot be laid off or otherwise fruitfully used.
- Formulate the LP useful in maximizing the weekly profit contribution.
 - It has just been discovered that two important considerations were not included.
 - Up to 100 hours of overtime assembly labor can be scheduled at a cost of \$5 per hour.
 - The sheet metal supplier only charges 12 cents per square foot for weekly usage in excess of 5000 square feet.

Which of the above considerations could easily be incorporated in the LP model and how? If one or both cannot be easily incorporated, indicate how you might nevertheless solve the problem.

3. Review the solution to the 5-product, 3-machine product mix problem introduced at the beginning of the chapter.
- What is the marginal value of an additional hour of capacity on each of the machines?
 - The current selling price of product *A* is \$5. What would the price have to be before we would produce any *A*?
 - It would be profitable to sell more of product *E* at \$4 if you could, but it is not profitable to sell *E* at \$3 per unit even though you can. What is the breakeven price at which you would be indifferent about selling any more *E*?
 - It is possible to gain additional capacity by renting by the hour automatic versions of each of the three machines. That is, they require no labor. What is the maximum hourly rate you would be willing to pay to rent each of the three types of automatic machines?

4. The Aviston Electronics Company manufactures motors for toys and small appliances. The marketing department is predicting sales of 6,100 units of the Dynamonster motor in the next quarter. This is a new high and meeting this demand will test Aviston's production capacities. A Dynamonster is assembled from three components: a shaft, base, and cage. It is clear that some of these components will have to be purchased from outside suppliers because of limited in-house capacity. The variable in-house production cost per unit is compared with the outside purchase cost in the following table.

Component	Outside Cost	Inside Cost
Shaft	1.21	0.81
Base	2.50	2.30
Cage	1.95	1.45

Aviston's plant consists of three departments. The time requirements in hours of each component in each department if manufactured in-house are summarized in the following table. The hours available for Dynamonster production are listed in the last row.

Component	Cutting Department	Shaping Department	Fabrication Department
Shaft	0.04	0.06	0.04
Base	0.08	0.02	0.05
Cage	0.07	0.09	0.06
Capacity	820	820	820

- What are the decision variables?
 - Formulate the appropriate LP.
 - How many units of each component should be purchased outside?
5. Buster Sod's younger brother, Marky Dee, operates three ranches in Texas. The acreage and irrigation water available for the three farms are shown below:

Farm	Acreage	Water Available (acre feet)
1	400	1500
2	600	2000
3	300	900

Three crops can be grown. However, the maximum acreage that can be grown of each crop is limited by the amount of appropriate harvesting equipment available. The three crops are described below:

Crop	Total Harvesting Capacity (in acres)	Water Requirements (in acre-feet/acre)	Expected Profit (in \$/acre)
Milo	700	6	400
Cotton	800	4	300
Wheat	300	2	100

Any combination of crops may be grown on a farm.

- a) What are the decision variables?
 - b) Formulate the LP.
6. Review the formulation and solution of the American Metal Fabricating process selection/product mix problem in this chapter. Based on the solution report:
- a) What is the value of an additional hour of capacity on the B_4 machine?
 - b) What is the value of an additional 2 hours of capacity on the B_3 machine?
 - c) By how much would one have to raise the profit contribution/1,000 ft. of $\frac{1}{4}$ " material before it would be worth producing more of it?
 - d) If the speed of machine B_5 could be doubled without changing the labor cost, what would it be worth per week? (Note labor on B_5 is \$17/hour.)
7. A coupon recently appeared in an advertisement in the weekend edition of a newspaper. The coupon provided \$1 off the price of any size jar of Ocean Spray cranberry juice. The cost of the weekend paper was more than \$1.

Upon checking at a local store, we found two sizes available as follows:

Size in oz.	Price	Price/oz. w/o Coupon	Price/oz. with Coupon
32	2.09	.0653125	.0340625
48	2.89	.0602083	.039375

What questions, if any, should we ask in deciding which size to purchase? What should be our overall objective in analyzing a purchasing decision such as this?

7

Covering, Staffing & Cutting Stock Models

7.1 Introduction

Covering problems tend to arise in service industries. The crucial feature is that there is a set of requirements to be covered. We have available to us various activities, each of which helps cover some, but not all, the requirements. The qualitative form of a covering problem is:

Choose a minimum cost set of activities
Subject to
The chosen activities cover all of our requirements.

Some examples of activities and requirement types for various problems are listed below:

Problem	Requirements	Activities
Staff scheduling	Number of people required on duty each period of the day or week.	Work or shift patterns. Each pattern covers some, but not all, periods.
Routing	Each customer must be visited.	Various feasible trips, each of which covers some, but not all, customers.
Cutting of bulk raw material stock (e.g., paper, wood, steel, textiles)	Units required of each finished good size.	Cutting patterns for cutting raw material into various finished good sizes. Each pattern produces some, but not every, finished good.

In the next sections, we look at several of these problems in more detail.

7.1.1 Staffing Problems

One part of the management of most service facilities is the scheduling or staffing of personnel. That is, deciding how many people to use on what shifts. This problem exists in staffing the information operators department of a telephone company, a toll plaza, a large hospital, and, in general, any facility that must provide service to the public.

The solution process consists of at least three parts: (1) Develop good forecasts of the number of personnel required during each hour of the day or each day of the week during the scheduling period. (2) Identify the possible shift patterns, which can be worked based on the personnel available and work agreements and regulations. A particular shift pattern might be to work Tuesday through Saturday and then be off two days. (3) Determine how many people should work each shift pattern, so costs are minimized and the total number of people on duty during each time period satisfies the requirements determined in (1). All three of these steps are difficult. LP can help in solving step 3.

One of the first published accounts of using optimization for staff scheduling was by Edie (1954). He developed a method for staffing tollbooths for the New York Port Authority. Though old, Edie's discussion is still very pertinent and thorough. His thoroughness is illustrated by his summary (p. 138): "A trial was conducted at the Lincoln Tunnel...Each toll collector was given a slip showing his booth assignments and relief periods and instructed to follow the schedule strictly...At no times did excessive backups occur...The movement of collectors and the opening and closing of booths took place without the attention of the toll sergeant. At times, the number of booths were slightly excessive, but not to the extent previously... Needless to say, there is a good deal of satisfaction..."

7.1.2 Example: Northeast Tollway Staffing Problems

The Northeast Tollway out of Chicago has a toll plaza with the following staffing demands during each 24-hour period:

Hours	Collectors Needed
12 A.M. to 6 A.M.	2
6 A.M. to 10 A.M.	8
10 A.M. to Noon	4
Noon to 4 P.M.	3
4 P.M. to 6 P.M.	6
6 P.M. to 10 P.M.	5
10 P.M. to 12 Midnight	3

Each collector works four hours, is off one hour, and then works another four hours. A collector can be started at any hour. Assuming the objective is to minimize the number of collectors hired, how many collectors should start work each hour?

Formulation and Solution

Define the decision variables:

- x_1 = number of collectors to start work at 12 midnight,
- x_2 = number of collectors to start work at 1 A.M.,
- .
- .
- .
- x_{24} = number of collectors to start work at 11 P.M.

Sets Based Formulation

A “sets” based formulation for this problem in LINGO is quite compact. There are two sets, one for the 24-hour day and the other for the nine-hour shift. Note the use of the *@WRAP* function to modulate the index for the *X* variable:

```

MODEL: ! 24 hour shift scheduling;
SETS: !Each shift is 4 hours on, 1 hour off, 4 hours on;
  HOUR/1..24/: X, NEED;
ENDSETS
DATA:
  NEED=2 2 2 2 2 8 8 8 8 4 4 3 3 3 3 6 6 5 5 5 5 3 3;
ENDDATA
MIN = @SUM( HOUR(I) : X(I) );
@FOR( HOUR( I) : ! People on duty in hour I are those who
  started 9 or less hours earlier, but not 5;
  @SUM( HOUR( J) | (J#LE#9) #AND# (J#NE#5) : X(@WRAP( (I-J+1), 24) )) >= NEED(I) );
END

```

When solved as an LP, we get an objective value of 15.75 with the following variables nonzero:

$x_2 = 5$	$x_5 = 0.75$	$x_{11} = 1$	$x_{16} = 1$
$x_3 = 0.75$	$x_6 = 0.75$	$x_{14} = 1$	$x_{17} = 1$
$x_4 = 0.75$	$x_7 = 0.75$	$x_{15} = 2$	$x_{18} = 1$

The answer is not directly useful because some of the numbers are fractional. To enforce the integrality restriction, use the *@GIN* function as in the following line:

```
@FOR( HOUR( I) : @GIN( X(I) ) );
```

When it is solved, we get an objective value of 16 with the following variables nonzero:

$x_2 = 4$	$x_5 = 1$	$x_{14} = 1$	$x_{17} = 2$
$x_3 = 1$	$x_6 = 1$	$x_{15} = 1$	$x_{18} = 1$
$x_4 = 1$	$x_7 = 1$	$x_{16} = 2$	

One of the biggest current instances of this kind of staffing problem is in telephone call centers. Examples are telephone order takers for catalog retailers and credit checkers at credit card service centers. A significant fraction of the population of Omaha, Nebraska works in telephone call centers. A typical shift pattern at a call center consists of 8 hours of work split by a 15 minute break, a half hour lunch break, and another 15 minute break.

7.1.3 Additional Staff Scheduling Features

In a complete implementation there may be a fourth step, rostering, in addition to the first three steps of forecasting, work pattern identification, and work pattern selection. In rostering, specific individuals by name are assigned to specific work patterns. In some industries, e.g., airlines, individuals (e.g., pilots) are allowed to bid on the work patterns that have been selected.

In some staffing situations, there may be multiple skill requirements that need to be covered, e.g. during the first hour there must be at least 3 Spanish speakers on duty and at least 4 English speakers. Different employees may have different sets of skills, e.g., some may speak only English, some are conversant in both English and Spanish, etc.

In some situations, e.g., mail processing, demand may be postponeable by one or two periods, so that we are allowed to be understaffed, say during a peak period, if the carryover demand can be processed in the next period.

In almost all situations, demand is somewhat random so that staff requirements are somewhat soft. We might say that we need at least ten people on duty during a certain period, however, if we have eleven on duty, the extra person will probably not be standing around idle during the full period. There is a good chance that by chance demand will be higher than the point forecast so that we can use the extra person. The queueing theory methods of chapter 18 are frequently used to provide estimates of the marginal benefit of each unit of overstaffing.

7.2 Cutting Stock and Pattern Selection

In industries such as paper, plastic food wrap, and textiles, products are manufactured in large economically produced sizes at the outset. These sizes are cut into a variety of smaller, more usable sizes as the product nears the consumer. The determination of how to cut the larger sizes into smaller sizes at minimal cost is known as the cutting stock problem. As an example of the so-called one-dimensional cutting stock problem, suppose machine design dictates material is manufactured in 72-inch widths. There are a variety of ways of cutting these smaller widths from the 72-inch width, two of which are shown in Figure 7.1.

Figure 7.1 Example Cutting Patterns

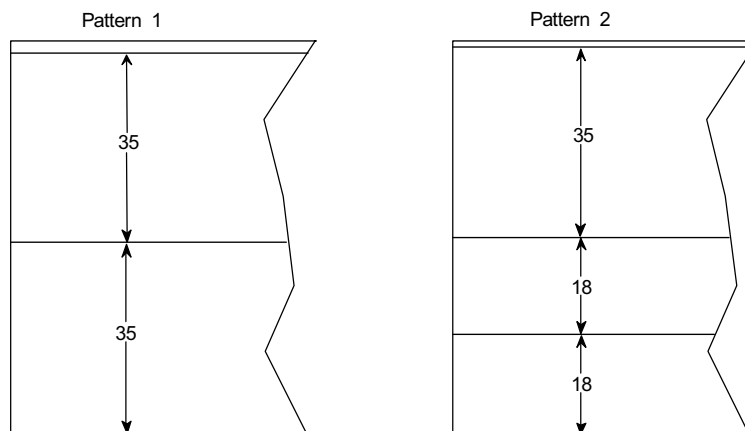

Pattern 1 has 2 inches of edge waste ($72 - 2 \times 35 = 2$), whereas there is only 1 inch of edge waste ($72 - 2 \times 18 - 35 = 1$) with pattern 2. Pattern 2, however, is not very useful unless the number of linear feet of 18-inch material required is about twice the number of linear feet of 35-inch material required. Thus, a compromise must be struck between edge waste and end waste.

The solution of a cutting stock problem can be partitioned into the 3-step procedure discussed earlier: (1) Forecast the needs for the final widths. (2) Construct a large collection of possible patterns for cutting the large manufactured width(s) into the smaller widths. (3) Determine how much of each pattern should be run of each pattern in (2), so the requirements in (1) are satisfied at minimum cost. Optimization can be used in performing step (3).

Many large paper manufacturing firms have LP-based procedures for solving the cutting stock problem. Actual cutting stock problems may involve a variety of cost factors in addition to the edge waste/end waste compromise. The usefulness of the LP-based procedure depends upon the importance of these other factors. The following example illustrates the fundamental features of the cutting stock problem with no complicating cost factors.

7.2.1 Example: Cooldot Cutting Stock Problem

The Cooldot Appliance Company produces a wide range of large household appliances such as refrigerators and stoves. A significant portion of the raw material cost is due to the purchase of sheet steel. Currently, sheet steel is purchased in coils in three different widths: 72 inches, 48 inches, and 36 inches. In the manufacturing process, eight different widths of sheet steel are required: 60, 56, 42, 38, 34, 24, 15, and 10 inches. All uses require the same quality and thickness of steel.

A continuing problem is trim waste. For example, one way of cutting a 72-inch width coil is to slit it into one 38-inch width coil and two 15-inch width coils. There will then be a 4-inch coil of trim waste that must be scrapped.

The prices per linear foot of the three different raw material widths are 15 cents for the 36-inch width, 19 cents for the 48-inch width, and 28 cents for the 72-inch width. Simple arithmetic reveals the costs per inch \times foot of the three widths are $15/36 = 0.416667$ cents/(inch \times foot), 0.395833 cents/(inch \times foot), and 0.388889 cents/(inch \times foot) for the 36", 48", and 72" widths, respectively.

The coils may be slit in any feasible solution. The possible cutting patterns for efficiently slitting the three raw material widths are tabulated below.

For example, pattern C_4 corresponds to cutting a 72-inch width coil into one 24-inch width and four 10-inch widths with 8 inches left over as trim waste.

The lengths of the various widths required in this planning period are:

Width	60"	56"	42"	38"	34"	24"	15"	10"
Number of feet required	500	400	300	450	350	100	800	1000

The raw material availabilities this planning period are 1600 ft. of the 72-inch coils and 10,000 ft. each of the 48-inch and 36-inch widths.

How many feet of each pattern should be cut to minimize costs while satisfying the requirements of the various widths? Can you predict beforehand the amount of 36-inch material used?

48-Inch Raw Material									
D_0	0	0	1	0	0	0	0	0	6
D_1	0	0	0	1	0	0	0	1	0
D_2	0	0	0	0	1	0	0	1	4
D_3	0	0	0	0	0	2	0	0	0
D_4	0	0	0	0	0	1	1	0	9
D_5	0	0	0	0	0	1	0	2	4
D_6	0	0	0	0	0	0	3	0	3
D_7	0	0	0	0	0	0	2	1	8
D_8	0	0	0	0	0	0	1	3	3
D_9	0	0	0	0	0	0	0	4	8
36-Inch Raw Material									
E_0	0	0	0	0	1	0	0	0	2
E_1	0	0	0	0	0	1	0	1	2
E_2	0	0	0	0	0	0	2	0	6
E_3	0	0	0	0	0	0	1	2	1
E_4	0	0	0	0	0	0	0	3	6

For accounting purposes, it is useful to additionally define:

- T_1 = number of feet cut of 72-inch patterns,
- T_2 = number of feet cut of 48-inch patterns,
- T_3 = number of feet cut of 36-inch patterns,
- W_1 = inch \times feet of trim waste from 72-inch patterns,
- W_2 = inch \times feet of trim waste from 48-inch patterns,
- W_3 = inch \times feet of trim waste from 36-inch patterns,
- X_1 = number of excess feet cut of the 60-inch width,
- X_2 = number of excess feet cut of the 56-inch width,
- .
- .
- .
- X_8 = number of excess feet cut of the 10-inch width.

It may not be immediately clear what the objective function should be. One might be tempted to calculate a cost of trim waste per foot for each pattern cut and then minimize the total trim waste cost. For example:

$$\text{MIN} = 0.3888891W_1 + 0.395833W_2 + 0.416667W_3;$$

However, such an objective can easily lead to solutions with very little trim waste, but very high cost. This is possible in particular when the cost per square inch is not the same for all raw material widths. A more reasonable objective is to minimize the total cost. That is:

$$\text{MIN} = 28 * T_1 + 19 * T_2 + 15 * T_3;$$

Incorporating this objective into the model, we have:

```

MODEL:
SETS:
! Each raw material has a Raw material width, Total used,
  Waste total, Cost per unit, Waste cost, and Supply available;
RM: RWDTH,T, W, C, WCOST, S;
! Each Finished good has a Width, units Required. eXtra produced;
FG: FWDTH, REQ, X;
PATTERN: USERM, WASTE, AMT;
PX( PATTERN, FG): NUM;
ENDSETS
DATA:
! The raw material widths;
  RM =      R72      R48      R36;
  RWDTH=    72      48      36;
  C =      .28      .19      .15;
  WCOST= .00388889 .00395833 .00416667;
  S =    1600    10000    10000;
! The finished good widths;
  FG = F60 F56 F42 F38 F34 F24 F15 F10;
  FWDTH= 60 56 42 38 34 24 15 10;
  REQ= 500 400 300 450 350 100 800 1000;
! Index of R.M. that each pattern uses;
USERM = 1 1 1 1 1 1 1 1 1 1
        1 1 1 1 1 1 1 1 1 1
        1 1 1 1 1 1 1 1 1
        2 2 2 2 2 2 2 2 2 2
        3 3 3 3 3;
! How many of each F.G. are in each R.M. pattern;
NUM= 1 0 0 0 0 0 0 0 1
      0 1 0 0 0 0 0 1 0
      0 1 0 0 0 0 0 0 1
      0 0 1 0 0 1 0 0 0
      0 0 1 0 0 0 2 0
      0 0 1 0 0 0 1 1
      0 0 1 0 0 0 0 3
      0 0 0 1 1 0 0 0
      0 0 0 1 0 1 0 1
      0 0 0 1 0 0 2 0
      0 0 0 1 0 0 1 1
      0 0 0 1 0 0 0 3
      0 0 0 0 2 0 0 0
      0 0 0 0 1 1 0 1
      0 0 0 0 1 0 2 0
      0 0 0 0 1 0 1 2
      0 0 0 0 1 0 0 3
      0 0 0 0 0 3 0 0
      0 0 0 0 0 2 1 0
      0 0 0 0 0 2 0 2
      0 0 0 0 0 1 3 0
      0 0 0 0 0 1 2 1
      0 0 0 0 0 1 1 3
      0 0 0 0 0 1 0 4

```

```

0 0 0 0 0 0 4 1
0 0 0 0 0 0 3 2
0 0 0 0 0 0 2 4
0 0 0 0 0 0 1 5
0 0 0 0 0 0 0 7
0 0 1 0 0 0 0 0
0 0 0 1 0 0 0 1
0 0 0 0 1 0 0 1
0 0 0 0 0 2 0 0
0 0 0 0 0 1 1 0
0 0 0 0 0 1 0 2
0 0 0 0 0 0 3 0
0 0 0 0 0 0 2 1
0 0 0 0 0 0 1 3
0 0 0 0 0 0 0 4
0 0 0 0 1 0 0 0
0 0 0 0 0 1 0 1
0 0 0 0 0 0 2 0
0 0 0 0 0 0 1 2
0 0 0 0 0 0 0 3;
ENDDATA
! Minimize cost of raw material used;
MIN = TCOST;
TCOST = @SUM(RM(I): C(I)*T(I) );

@FOR( RM( I):
T( I) = @SUM( PATTERN( K) | USERM(K) #EQ# I: AMT( K));
! Raw material supply constraints;
T(I) <= S(I);
);

! Must produce at least amount required of each F.G.;
@FOR( FG(J):
@SUM(PATTERN(K): NUM(K,J)*AMT(K)) = REQ(J) + X(J);
);

! Turn this on to get integer solutions;
!@FOR( PATTERN(K): @GIN(AMT(K)));

! Waste related computations;
! Compute waste associated with each pattern;
@FOR( PATTERN(K):
WASTE(K) = RWDTH(USERM(K)) - @SUM(FG(J): FWDTH(J)*NUM(K,J));
);
! Waste for each R.M. in this solution;
@FOR( RM( I):
W(I) = @SUM( PATTERN( K) | USERM(K) #EQ# I: WASTE(K)*AMT( K));
);

! Compute total cost of waste;
TOTWASTE = @SUM( RM(I): WCOST(I)*W(I) );
END

```

If you minimize cost of waste, then you will get a different solution than if you minimize total cost of raw materials. Two different solutions obtained under the two different objectives are compared in the following table:

Cutting Stock Solutions		
Nonzero Patterns	Trim Waste Minimizing Solution Feet to Cut	Total Cost Minimizing Solution Feet to Cut
A_1	500	500
A_2	400	400
A_5	200	171.4286
A_7	100	128.5714
A_8	350	350
A_9	50	3.571429
B_8	0	32.14286
C_9	0	14.28571
D_1	150	96.42857
D_3	25	0
Trim Waste Cost	\$5.44	\$5.55
Total Cost	\$2348.00	\$466.32
X_4	100.000	0
X_6	19650	0
T_1	1600	1600
T_2	10000	96.429
T_3	0	0

The key difference in the solutions is the “Min trim waste” solution uses more of the 48" width raw material and cuts it in a way, so the edge waste is minimized. More material of the 42" width and the 34" width is cut than needed, however, because the objective function does not count this as waste.

Both solutions involve fractional answers. By turning on the @GIN declaration you can get an integer answer. The cost of the “cost minimizing” solution increases to \$466.34.

7.2.3 Generalizations of the Cutting Stock Problem

In large cutting stock problems, it may be unrealistic to generate all possible patterns. There is an efficient method for generating only the patterns that have a very high probability of appearing in the optimal solution. It is beyond the scope of this section to discuss this procedure. However, it does become important in large problems. See Chapter 18 for details. Dyckhoff (1981) describes another formulation that avoids the need to generate patterns. However, that formulation may have a very large number of rows.

Complications

In complex cutting stock problems, the following additional cost considerations may be important:

1. *Fixed cost of setting up a particular pattern.* This cost consists of lost machine time, labor, etc. This motivates solutions with few patterns.
2. *Value of overage or end waste.* For example, there may be some demand next period for the excess cut this period.
3. *Underage cost.* In some industries, you may supply plus or minus, say 5%, of a specified quantity. The cost of producing the least allowable amount is measured in foregone profits.
4. *Machine usage cost.* The cost of operating a machine is usually fairly independent of the material being run. This motivates solutions that cut up wide raw material widths.
5. *Material specific products.* It may be impossible to run two different products in the same pattern if they require different materials (e.g., different thickness, quality, surface finish or type).
6. *Upgrading costs.* It may be possible to reduce setup, edge-waste, and end-waste costs by substituting a higher-grade material than required for a particular demand width.
7. *Order splitting costs.* If a demand width is produced from several patterns, then there will be consolidation costs due to bringing the different lots of the output together for shipment.
8. *Stock width change costs.* A setup involving only a pattern change usually takes less time than one involving both a pattern change and a raw material width change. This motivates solutions that use few raw material widths.
9. *Minimum and maximum allowable edge waste.* For some materials, a very narrow ribbon of edge waste may be very difficult to handle. Therefore, one may wish to restrict attention to patterns that have either zero edge waste or edge waste that exceeds some minimum, such as two centimeters. On the other hand, one may also wish to specify a maximum allowable edge waste. For example, in the paper industry, edge waste may be blown down a recycling chute. Edge waste wider than a certain minimum may be too difficult to blow down this chute.
10. *Due dates and sequencing.* Some of the demands need to be satisfied immediately, whereas others are less urgent. The patterns containing the urgent or high priority products should be run first. If the urgent demands appear in the same patterns as low priority demands, then it is more difficult to satisfy the high priority demands quickly.
11. *Inventory restrictions.* Typically, a customer's order will not be shipped until all the demands for the customer can be shipped. Thus, one is motivated to distribute a given customer's demands over as few patterns as possible. If every customer has product in every pattern, then no customer's order can be shipped until every pattern has been run. Thus, there will be substantial work in process inventory until all patterns have been run.
12. *Limit on 1-set patterns.* In some industries, such as paper, there is no explicit cost associated with setting up a pattern, but there is a limit on the rate at which pattern changes can be made. It may take about 15 minutes to do a pattern change, much of this work being done off-line without shutting down the main machine. The run time to produce one roll set might take 10 minutes. Thus, if too many 1-set patterns are run, the main machine will have to wait for pattern changes to be completed.

13. *Pattern restrictions.* In some applications, there may be a limit on the total number of final product widths that may appear in a pattern, and/or a limit on the number of “small” widths in a pattern. The first restriction would apply, for example, if there were a limited number of take-up reels for winding the slit goods. The second restriction might occur in the paper industry where rolls of narrow product width have a tendency to fall over, so one does not want to have too many of them to handle in a single pattern. Some demanding customers may request their product be cut from a particular position (e.g., the center) of a pattern, because they feel the quality of the material is higher in that position.
14. *Pattern pairing.* In some plastic wrap manufacturing, the production process, by its nature, produces two widths of raw material simultaneously, an upper output and a lower output. Thus, it is essentially unavoidable that one must run the same number of feet of whatever pattern is being used on the upper output as on the lower output. A similar situation sometimes happens by accident in paper manufacturing. If a defect develops on the “production belt”, a small width of paper in the interior of the width is unusable. Thus, the machine effectively produces two output widths, one to the left of the defect, the other to the right of the defect.

The most troublesome complications are high fixed setup costs, order-splitting costs, and stock width change costs. If they are important, then one will usually be forced to use some ad hoc, manual solution procedure. An LP solution may provide some insight into which solutions are likely to be good, but other methods must be used to determine a final workable solution.

7.2.4 Two-Dimensional Cutting Stock Problems

The one-dimensional cutting stock problem is concerned with the cutting of a raw material that is in coils. The basic idea still applies if the raw material comes in sheets and the problem is to cut these sheets into smaller sheets. For example, suppose plywood is supplied in 48- by 96-inch rectangular sheets and the end product demand is for sheets with dimensions in inches of 36×50 , 24×36 , 20×60 , and 18×30 . Once you have enumerated all possible patterns for cutting a 48×96 sheet into combinations of the four smaller sheets, then the problem is exactly as before.

Enumerating all possible two-dimensional patterns may be a daunting task. Two features of practical two-dimensional cutting problems can reduce the size of this task: (a) orientation requirements, and (b) “guillotine” cut requirements. Applications in which (a) is important are in the cutting of wood and fabric. For reasons of strength or appearance, a demand unit may be limited in how it is positioned on the raw material (Imagine a plaid suit for which the manufacturer randomly oriented the pattern on the raw material). Any good baseball player knows the grain of the bat must face the ball when hitting. Attention must be paid to the grain of the wood if the resulting wood product is to be used for structural or aesthetic purposes. Glass is an example of a raw material for which orientation is not important. A pattern is said to be cuttable with guillotine cuts if each cut must be made by a shear across the full width of the item being cut.

7.3 Crew Scheduling Problems

A major component of the operating cost of an airline is the labor cost of its crews. Managing the aircraft and crews of a large airline is a complex scheduling problem. Paying special attention to these scheduling problems can be rewarding. The yearly cost of a crew member far exceeds the one-time cost of a typical computer, so devoting some computing resources to make more efficient use of crews and airplanes is attractive. One small part of an airline’s scheduling problems is discussed below.

Large airlines face a staffing problem known as the crew-scheduling problem. The requirements to be covered are the crew requirements of the flights that the airline is committed to fly during the next scheduling period (e.g., one month). During its working day, a specific crew typically, but not necessarily, flies a number of flights on the same aircraft. The problem is to determine which flights should comprise the day's work of a crew.

The approach taken by many airlines is similar to the approach described for general staffing problems: (1) Identify the demand requirements (i.e., the flights to be covered). (2) Generate a large number of feasible sequences of flights one crew could cover in a work period. (3) Select a minimum cost subset of the collections generated in (2), so the cost is minimized and every flight is contained in exactly one of the selected collections.

Integer programming(IP) can be used for step (3). Until 1985, most large airlines used computerized ad hoc or heuristic procedures for solving (3) because the resulting IP tends to be large and difficult to solve. Marsten, Muller, and Killion (1979), however, described an IP-based solution procedure that was used very successfully by Flying Tiger Airlines. Flying Tiger had a smaller fleet than the big passenger carriers, so the resulting IP could be economically solved and gave markedly lower cost solutions than the ad hoc, heuristic methods. These optimizing methods are now being extended to large airlines.

A drastically simplified version of the crew-scheduling problem is given in the following example. This example has only ten flights to be covered. By contrast, a typical major airline has over 2000 flights per day to be covered.

7.3.1 Example: Sayre-Priors Crew Scheduling

The Sayre-Priors Airline and Stormdoor Company is a small diversified company that operates the following set of scheduled flights:

Flights			
Flight Number	Origin	Destination	Time of Day
101	Chicago	Los Angeles	Afternoon
410	New York	Chicago	Afternoon
220	New York	Miami	Night
17	Miami	Chicago	Morning
7	Los Angeles	Chicago	Afternoon
13	Chicago	New York	Night
11	Miami	New York	Morning
19	Chicago	Miami	Night
23	Los Angeles	Miami	Night
3	Miami	Los Angeles	Afternoon

The flight schedule is illustrated graphically in the figure below:

Figure: Flight Schedule

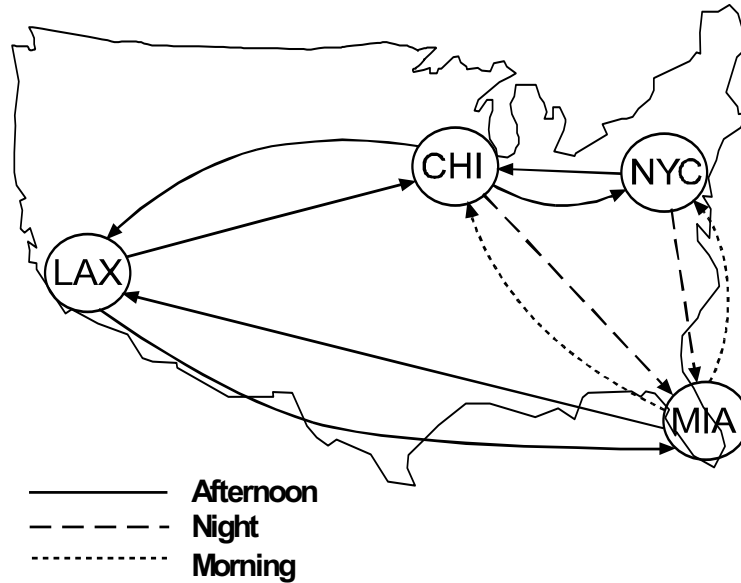

The Flight Operations Staff would like to set up a low-cost crew assignment schedule. The basic problem is to determine the next flight, if any, a crew operates after it completes one flight. A basic concept needed in understanding this problem is that of a tour. The characteristics of a tour are as follows:

- A tour consists of from one to three connecting flights.
- A tour has a cost of \$2,000 if it terminates in its city of origin.
- A tour that requires “deadheading” (i.e., terminates in a city other than the origin city) costs \$3,000.

In airline parlance, a tour is frequently called a “pairing” or a “rotation” because a tour consist of a pair of duty periods, an outbound one, and a return one. The following are examples of acceptable tours:

Tour	Cost
17, 101, 23	\$2,000
220, 17, 101	\$3,000
410, 13	\$2,000

In practice, the calculation of the cost of a tour is substantially more complicated than above. There might be a minimum fixed payment, c_f , to a crewmember simply for being on duty, a guaranteed rate per hour, c_d , while in the airplane, and a guaranteed rate per hour, c_e , for total elapsed

time away from home so that we might have: $pairing_cost(i) = \max\{c_f, c_d * flying_time(i), c_e * elapsed_time(i)\}$.

7.3.2 Solving the Sayre/Priors Crew Scheduling Problem

The first thing to do for this small problem is to enumerate all feasible tours. We do not consider a collection of flights that involve an intermediate layover a tour. There are 10 one-flight tours, 14 two-flight tours, and either 37 or 41 three-flight tours depending upon whether one distinguishes the origin city on a non-deadheading tour. These tours are indicated in the following table:

List of Tours

One-Flight Tours		Cost	Two-Flight Tours		Cost	Three-Flight Tours		Cost
1.	101	\$3,000	11.	101, 23	\$3,000	25.	101, 23, 17	\$2,000
2.	410	\$3,000	12.	410, 13	\$2,000	26.	101, 23, 11	\$3,000
3.	220	\$3,000	13.	410, 19	\$3,000	27.	410, 19, 17	\$3,000
4.	17	\$3,000	14.	220, 17	\$3,000	28.	410, 19, 11	\$2,000
5.	7	\$3,000	15.	220, 11	\$2,000	29.	220, 17, 101	\$3,000
6.	13	\$3,000	16.	17, 101	\$3,000	30.	220, 11, 410	\$3,000
7.	11	\$3,000	17.	7, 13	\$3,000	25.	17, 101, 23	\$2,000
8.	19	\$3,000	18.	7, 19	\$3,000	31.	7, 19, 17	\$3,000
9.	23	\$3,000	19.	11, 410	\$3,000	32.	7, 19, 11	\$3,000
10.	3	\$3,000	20.	19, 17	\$2,000	33.	11, 410, 13	\$3,000
			21.	19, 11	\$3,000	28.	11, 410, 19	\$2,000
			22.	23, 17	\$3,000	34.	19, 17, 101	\$3,000
			23.	23, 11	\$3,000	28.	19, 11, 410	\$2,000
			24.	3, 23	\$2,000	25.	23, 17, 101	\$2,000
						35.	23, 11, 410	\$3,000
						36.	3, 23, 17	\$3,000
						37.	3, 23, 11	\$3,000

Define the decision variables:

$$T_i = \begin{cases} 1 & \text{if tour } i \text{ is used} \\ 0 & \text{if tour } i \text{ is not used, for } i = 1, 2, \dots, 37. \end{cases}$$

We do not distinguish the city of origin on non-deadheading three-flight tours. The formulation, in words, is:

Minimize the cost of the tours selected;
 Subject to,
 For each flight leg i :
 The number of tours selected must include exactly one that covers flight i .

When solved simply as an LP, the solution is naturally integer, with the tours selected being:

Tour	Flights
T17	7, 13
T24	3, 23
T28	410, 19, 11
T29	220, 17, 101

The cost of this solution is \$10,000.

It can be shown, e.g., by adding the constraint: $T_{17} + T_{24} + T_{28} + T_{29} \leq 3$, that there is one other solution with a cost of \$10,000, namely:

Tour	Flights
T12	410, 13
T24	3, 23
T29	220, 17, 101
T32	7, 11, 19

The kind of IP's that result from the crew scheduling problem with more than 500 constraints have proven somewhat difficult to solve. A general formulation of the Sayre/Priors problem is given in section 7.4.

7.3.3 Additional Practical Details

An additional detail sometimes added to the above formulation in practice is crew-basing constraints. Associated with each tour is a home base. Given the number of pilots living near each home base, one may wish to add a constraint for each home base that puts an upper limit on the number of tours selected for that home base.

A simplification in practice is that a given pilot is typically qualified for only one type of aircraft. Thus, a separate crew-scheduling problem can be solved for each aircraft fleet (e.g., Boeing 747, Airbus 320, etc.). Similarly, cabin attendant crews can be scheduled independently of flight (pilot) crews.

After crew schedules have been selected, there still remains the rostering problem of assigning specific crew schedules to specific pilots. In the U.S., perhaps by union agreement, many of the major airlines allow pilots to select schedules by a bidding process. In some smaller airlines and in non-U.S. airlines schedules may be assigned to specific pilots by a central planning process. The bidding process may make some of the crew members more happy, at least the ones with high seniority, however, the centralized assignment process may be more efficient because it eliminates inefficient gaming of the system.

Uncertainties due to bad weather and equipment breakdowns are an unfortunate fact of airline life. Thus, one wishes to have crew schedules that are robust or insensitive to disruptions. A crew schedule tends to be disruption sensitive if the schedule requires crews to change planes frequently and if the connection times between these changes are short. Suppose that a plane is delayed a half hour by a need to get some equipment repaired. If the crew of this plane is scheduled to change planes at the next stop, then at the next stop the airline may need or wish to delay up to three flights: a) the flight that is scheduled to use this plane, b) the flight which is scheduled to use this flight crew, and c) the flight to which a significant number of passengers on this flight are transferring. In our little example we saw that there were alternate optima. Thus, in addition to minimizing total crew costs,

we might wish to secondarily minimize expected delays by avoiding tours that involve crews changing planes a) such that there is short change-over time, b) different from the plane to which most of the passengers are changing (thus two flights must be delayed), c) at an airport where there are few backup crews available to take over for the delayed crew.

7.4 A Generic Covering/Partitioning/Packing Model

The model given for the crew-scheduling problem was very specific to that particular problem. The following is a fairly general one for any standard, so-called covering, partitioning or packing problem. This model takes the viewpoint of facilities and customers. Each facility or pattern, if opened, serves a specified set of customers or demands. Specialized to our crew-scheduling example, a tour is a facility, and a flight is a customer. The main data to be entered are the "2-tuples" describing which facilities serve which customers. This model allows considerable flexibility in specifying whether customers are over served or under served. If the parameter *BUDU* is set to 0, this means that every customer (or flight) must be served by at least one open facility (or tour). This is sometimes called a set covering problem. Alternatively, if *BUDV* is set to 0, then each flight can appear in at most one selected tour. This is sometimes called a set packing problem. If both *BUDV* and *BUDU* are set to zero, then each flight must appear in exactly one selected tour. This is sometimes called a set partitioning problem. It is called set partition because any feasible solution in fact partitions the set of customers into subsets, one subset for each chosen open facility (or tour).

```

! The set covering/partitioning/packing/ problem (COVERPAK);
SETS:
! Given a set of demands, a set of candidate patterns,
  and which demands are covered by each pattern,
  which patterns should be used?;
PATTERN: COST, T; ! The tours;
DMND: CU, CV, U, V;
! The "PATTERN serves demand" 2-tuples;
PXD( PATTERN, DMND);
ENDSETS
DATA:
  PATTERN = 1..37;
! Cost of each PATTERN;
  COST = 3 3 3 3 3 3 3 3 3 3 3 2 3 3 2 3 3 3 3 2
        3 3 3 2 2 3 3 2 3 3 3 3 3 3 3 3;
  DMND= F101 F410 F220 F17 F7 F13 F11 F19 F23 F3;
! Penalty cost/unit under at each demand;
  CU = 1 1 1 1 1 1 1 1 1 1 1 1;
! Penalty cost/unit over at each demand;
  CV = 1 1 1 1 1 1 1 1 1 1 1 1;

! Max allowed to spend on facilities;
  BUDGET = 9999;
! Max allowed underage at each demand,
  0 makes a covering or partitioning problem;
  BNDU = 0;
! Max allowed overage at each demand,
  0 makes it a packing or partitioning problem;
  BNDV = 0;
! Both = 0 makes it a partitioning problem;

```

```

PXD =
  1,F101 2,F410 3,F220 4,F17 5,F7 6,F13 7,F11 8,F19 9,F23 10,F3
  11,F101 11,F23 12,F410 12,F13 13,F410 13,F19 14,F220 14,F17
  15,F220 15,F11 16,F17 16,F101 17,F7 17,F13 18,F7 18,F19
  19,F11 19,F410 20,F19 20,F17 21,F19 21,F11 22,F23 22,F17
  23,F23 23,F11 24,F3 24,F23 25,F101 25,F23 25,F17
  26,F101 26,F13 26,F11 27,F410 27,F19 27,F17
  28,F410 28,F19 28,F11 29,F220 29,F17 29,F101 30,F220 30,F11 30,F410
  31,F7 31,F19 31,F17 32,F7 32,F19 32,F11 33,F11 33,F410
  34,F19 34,F17 34,F101 35,F23 35,F11 35,F410 36,F3 36,F23 36,F17
  37,F3 37,F23 37,F11;
ENDDATA
!-----;
! Minimize cost of facilities opened, demands poorly served;
  MIN = @SUM( PATTERN( I): COST( I) * T(I))
        + @SUM( DMND( J): CU( J) * U( J) + CV( J) * V( J));

! For each demand,
  sum of patterns serving it + under variable - over variable= 1;
@FOR( DMND( J):
  @SUM( PXD( I, J): T( I)) + U( J) - V( J) = 1;
);

! Stay within budget on facilities cost;
@SUM( PATTERN: COST * T) <= BUDGET;

! and demand service costs;
@SUM( DMND(J): CU(J) * U(J)) <= BNDU;
@SUM( DMND(J): CV(J) * V(J)) <= BNDV;

! A PATTERN is either open or it is not, no halvesies;
@FOR( PATTERN( I): @BIN( T( I)));

```

A solution obtained from this model is:

Variable	Value
Y(12)	1.000000
Y(24)	1.000000
Y(29)	1.000000
Y(32)	1.000000

Notice that it is different from our previous solution. It, however, also has a cost of 10(000), so it is an alternate optimum.

7.5 Problems

1. Certain types of facilities operate seven days each week and face the problem of allocating person power during the week as staffing requirements change as a function of the day of the week. This kind of problem is commonly encountered in public service and transportation organizations. Perhaps the most fundamental staffing problem involves the assignment of days off to full-time employees. In particular, it is regularly the case that each employee is entitled to two consecutive days off per week. If the number of employees required on each of the seven days of the week is given, then the problem is to find the minimum workforce size that will allow these demands to be met and then to determine the days off for the people in this workforce.

To be specific, let us study the problem faced by the Festus City Bus Company. The number of drivers required for each day of the week is as follows:

Mon	Tues	Wed	Thurs	Fri	Sat	Sun
18	16	15	16	19	14	12

How many drivers should be scheduled to start a five-day stint on each day of the week? Formulate this problem as a linear program. What is the optimal solution?

2. Completely unintentionally, several important details were omitted from the Festus City Staffing Problem (see previous question):
 - a) Daily pay is \$50 per person on weekdays, \$75 on Saturday, and \$90 on Sunday.
 - b) There are up to three people that can be hired who will work part-time, specifically, a 3-day week consisting of Friday, Sunday, and Monday. Their pay for this 3-day stint is \$200.

Modify the formulation appropriately. Is it obvious whether the part-time people will be used?

3. A political organization, Uncommon Result, wants to make a mass mailing to solicit funds. It has identified six "audiences" it wishes to reach. There are eight mailing lists it can purchase in order to get the names of the people in each audience. Each mailing list covers only a portion of the audiences. This coverage is indicated in the table below:

Mailing List	Audiences						Cost
	M.D.	LL.D.	D.D.S.	Business Executive	Brick Layers	Plumbers	
1	Y	N	N	Y	N	N	\$5000
2	N	Y	Y	N	N	N	\$4000
3	N	Y	N	N	N	Y	\$6000
4	Y	N	N	N	N	Y	\$4750
5	N	N	N	Y	N	Y	\$5500
6	N	N	Y	N	N	N	\$3000
7	N	Y	N	N	Y	N	\$5750
8	Y	N	N	N	Y	N	\$5250

A “Y” indicates the mailing list contains essentially all the names in the audience. An “N” indicates that essentially no names in the audience are contained in the mailing list. The costs associated with purchasing and processing a mailing list are given in the far right column. No change in total costs is incurred if an audience is contained in several mailing lists.

Formulate a model that will minimize total costs while ensuring all audiences are reached. Which mailing lists should be purchased?

4. The Pap-Iris Company prints various types of advertising brochures for a wide range of customers. The raw material for these brochures is a special finish paper that comes in 50-inch width rolls. The 50-inch width costs \$10 per inch-roll (i.e., \$500/roll). A roll is 1,000 feet long. Currently, Pap-Iris has three orders. Order number 1 is a brochure that is 16 inches wide with a run length of 400,000 feet. Order number 2 is a brochure that is 30 inches wide and has a run length of 80,000 feet. Order number 3 is a brochure that is 24 inches wide and has a run length of 120,000 feet. The major question is how to slit the larger raw material rolls into widths suitable for the brochures. With the paper and energy shortages, Pap-Iris wants to be as efficient as possible in its use of paper. Formulate an appropriate LP.
5. *Postal Optimality Analysis* (Due to Gene Moore). As part of a modernization effort, the U.S. Postal Service decided to improve the handling and distribution of bulk mail (second-, third- and fourth-class non-preferential) in the Chicago area. As part of this goal, a new processing facility was proposed for the Chicago area. One part of this proposal was development of a low-cost operational plan for the staffing of this facility. The plan would recognize the widely fluctuating hourly volume characteristic of such a facility and would suggest a staffing pattern or patterns that would accomplish the dual objectives of processing all mail received in a day while having no idle time.

A bulk mail processing facility, as the name implies, performs the function of receiving, unpacking, weighing, sorting by destination, and shipping of mail designated as non-preferential, including second class (bulk rate), third class (parcel post), and fourth class (books). It is frequently designed as a single purpose structure and is typically located in or adjacent to the large metropolitan areas, which produce this type of mail in significant volume. Although the trend in such facilities has been increased utilization of automated equipment (including highly sophisticated handling and sorting devices), paid manpower continues to account for a substantial portion of total operating expense.

Mail is received by the facility in mailbags and in containers. Both of which are shipped in trucks. It is also received in tied and wrapped packages, which are sent directly to the facility on railroad flatcars. Receipts of mail by the facility tend to be cyclical on a predictable basis throughout the 24-hour working day, resulting in the build-up of an “inventory” of mail during busy hours, which must be processed during less busy hours. A policy decision to have “no idle time” imposes a constraint on the optimal level of staffing.

Once the facility is ready for operations, it will be necessary to implement an operating plan that includes staffing requirements. A number of assumptions regarding such a plan are necessary at the outset. Some of them are based upon existing Postal Service policy, whereas others evolve from functional constraints. These assumptions are as follows:

- i.* Pieces of mail are homogeneous in terms of processing effort.
- ii.* Each employee can process 1800 pieces per hour.
- iii.* Only full shifts are worked (i.e., it is impossible to introduce additional labor inputs or reduce existing labor inputs at times other than shift changes).
- iv.* Shift changes occur at midnight, 8:00 A.M. and 4:00 P.M. (i.e., at the ends of the first, second and third shifts, respectively).
- v.* All mail arrivals occur on the hour.
- vi.* All mail must be processed the same day it is received (i.e., there may be no “inventory” carryover from the third shift to the following day’s first shift).
- vii.* Labor rates, including shift differential, are given in the following table:

Shift	\$/Hour	Daily Rate
1st (Midnight-8 A.M.)	7.80	62.40
2nd (8 A.M. -4 P.M.)	7.20	57.60
3rd (4 P.M. -Midnight)	7.60	60.80

- viii.* Hourly mail arrival is predictable and is given in the following table.

Cumulative Mail Arrival					
1st Shift		2nd Shift		3rd Shift	
Hour	Pieces	Hour	Pieces	Hour	Pieces
0100	56,350	0900	242,550	1700	578,100
0200	83,300	1000	245,000	1800	592,800
0300	147,000	1100	249,900	1900	597,700
0400	171,500	1200	259,700	2000	901,500
0500	188,650	1300	323,400	2100	908,850
0600	193,550	1400	369,950	2200	928,450
0700	210,700	1500	421,400	2300	950,500
0800	220,500	1600	485,100	2400	974,000

- a) Formulate the appropriate LP under the no idle time requirement. Can you predict beforehand the number to staff on the first shift? Will there always be a feasible solution to this problem for arbitrary arrival patterns?
- b) Suppose we allow idle time to occur. What is the appropriate formulation? Do you expect this solution to incur higher cost because it has idle time?

6. In the famous Northeast Tollway staffing problem, it was implied that at least a certain specified number of collectors were needed each period of the day. No extra benefit was assumed from having more collectors on duty than specified. You may recall that, because of the fluctuations in requirements over the course of the day, the optimal solution did have more collectors than required on duty during certain periods.

In reality, if more collectors are on duty than specified, the extra collectors are not completely valueless. The presence of the extra collectors results in less waiting for the motorists (boaters?). Similarly, if less than the specified number of collectors is on duty, the situation is not necessarily intolerable. Motorists will still be processed, but they may have to wait longer.

After much soul searching and economic analysis, you have concluded that one full-time collector costs \$100 per shift. An extra collector on duty for one hour results in \$10 worth of benefits to motorists. Further, having one less collector on duty than required during an one-hour period results in a waiting cost to motorists of \$50.

Assuming you wish to minimize total costs (motorists and collectors), show how you would modify the LP formulation. You only need illustrate for one constraint.

7. Some cities have analyzed their street cleaning and snow removal scheduling by methods somewhat analogous to those described for the Sayre-Priors airline problem. After a snowfall, each of specified streets must be swept by at least one truck.
- What are the analogs of the flight legs in Sayre-Priors?
 - What might be the decision variables corresponding to the tours in Sayre-Priors?
 - Should the constraints be equality or inequality in this case and why?
8. The St. Libory Quarry Company (SLQC) sells the rock that it quarries in four grades: limestone, chat, Redi-Mix-Grade, and coarse. A situation it regularly encounters is one in which it has large inventories of the grades it does not need and very little inventory in the grades needed at the moment. Large rocks removed from the earth are processed through a crusher to produce the four grades. For example, this week it appears the demand is for 50 tons of limestone, 60 tons of chat, 70 tons of Redi-Mix, and 30 tons of coarse. Its on-hand inventories for these same grades are respectively: 5, 40, 30, and 40 tons. For practical purposes, one can think of the crusher as having three operating modes: close, medium, and coarse. SLQC has gathered some data and has concluded one ton of quarried rock gets converted into the following output grades according to the crusher setting as follows:

Crusher Operating Mode	Tons Output per Ton Input				Operating Cost/Ton
	Limestone	Chat	Redi-Mix	Coarse	
Close	0.50	0.30	0.20	0.00	\$8
Medium	0.20	0.40	0.30	0.10	\$5
Coarse	0.05	0.20	0.35	0.40	\$3

SLQC would like to know how to operate its crusher to bring inventories up to the equivalent of at least two weeks worth of demand. Provide whatever help your current circumstances permit.

9. A certain optical instrument is being designed to selectively provide radiation over the spectrum from about 3500 to 6400 Angstrom units. To cover this optical range, a range of chemicals must be incorporated into the design. Each chemical provides coverage of a certain range. A list of the available chemicals, the range each covers, and its relative cost is provided below.

Chemical	Range Covered in Angstroms		Relative Cost
	Lower Limit	Upper Limit	
PBD	3500	3655	4
PPO	3520	3905	3
PPF	3600	3658	1
PBO	3650	4075	4
PPD	3660	3915	1
POPOP	3900	4449	6
A-NPO	3910	4095	2
NASAL	3950	4160	3
AMINO B	3995	4065	1
BBO	4000	4195	2
D-STILB	4000	4200	2
D-POPOP	4210	4405	2
A-NOPON	4320	4451	2
D-ANTH	4350	4500	2
4-METHYL-V	4420	5400	9
7-D-4-M	4450	4800	3
ESCULIN	4450	4570	1
NA-FLUOR	5200	6000	9
RHODAMINE-6G	5600	6200	8
RHODAMINE-B	6010	6400	8
ACRIDINE-RED	6015	6250	2

What subset of the available chemicals should be chosen to provide uninterrupted coverage from 3500 to 6400 Angstroms?

10. A manufacturer has the following orders in hand:

Order	X	Y	Z
Units	60,000	90,000	300,000
Selling Price/unit	.45	.24	.16

Each order is for a single distinct type of product. The manufacturer has four different production processes available for satisfying these orders. Each process produces a different combination of the three products. Each process costs \$0.50 per unit. The manufacturer must satisfy the volumes specified in the above table. The manufacturer formulated the following LP:

$$\begin{aligned} \text{Min } & .5 A + .5 B + .5 C + .5 D \\ \text{s.t. } & \\ & A \geq 60000 \\ & 2 B + C \geq 90000 \\ & A + C + 3 D \geq 300000 \end{aligned}$$

- a) Which products are produced by process C?
- b) Suppose the agreements with customers are such that, for each product, the manufacturer is said to have filled the order if the manufacturer delivers an amount within + or - 10% of the "nominal" volume in the above table. The customer pays for whatever is delivered. Modify the formulation to incorporate this more flexible arrangement.

11. The formulation and solution of a certain staff-scheduling problem are shown below:

$$\begin{aligned} \text{MIN } & M + T + W + R + F + S + N \\ & T + W + R + F + S \geq 14 \\ & W + R + F + S + N \geq 9 \\ & M + R + F + S + N \geq 8 \\ & M + T + F + S + N \geq 6 \\ & M + T + W + S + N \geq 17 \\ & M + T + W + R + N \geq 15 \\ & M + T + W + R + F \geq 18 \end{aligned}$$

END

Optimal solution found at step: 4
 Objective value: 19.0000000

Variable	Value	Reduced Cost
M	5.000000	.0000000
T	.0000000	.0000000
W	11.00000	.0000000
R	.0000000	.0000000
F	2.000000	.0000000
S	1.000000	.0000000
N	.0000000	.3333333
Row	Slack or Surplus	Dual Price
2	.0000000	-.3333333
3	5.000000	.0000000
4	.0000000	-.3333333
5	2.000000	.0000000
6	.0000000	-.3333333
7	1.000000	.0000000
8	.0000000	-.3333333

where, M, T, W, R, F, S, N is the number of people starting their five-day work week on Monday, Tuesday, Wednesday, Thursday, Friday, Saturday, and Sunday respectively.

- a) How many people are required on duty on Thursday?
 - b) Suppose that part-time helpers are available who will work the three-day pattern, Thursday, Friday, and Saturday. That is, if you hire one of them, they will work all three days. These people cost 20% more per day than the ordinary folk who work a five-day week. Let P denote the number of part-timers to hire. Show how to modify the formulation to incorporate this option.
 - c) Using information from the solution report, what can you say about the (economic) attractiveness of the part-time help?
12. Acie Knielson runs a small survey research company out of a little office on the Northwest side. He has recently been contracted to do a telephone survey of the head-of-household of at least 220 households. The demographics of the survey must satisfy the following profile:

Age of head-of-household	18-25	26-35	36-60	≥61
Households in survey (min):	30	50	100	40

When Acie makes a phone call, he knows only on average what kind of head-of-household he will find (if any). Acie can make either daytime or nighttime phone calls. Calls at night have a higher probability of success. However, they cost more because a higher wage must be paid. Being a surveyor, Acie has good statistics on all this. Specifically, from past experience, he knows he can expect:

Call Type	Percent of calls finding head-of-household of given type					Cost/call
	18-25	26-35	36-60	61 or more	Not at home	
Day	2%	2%	8%	15%	73%	\$2.50
Night	4%	14%	28%	18%	36%	\$5.50

In words, what are the decision variables? What are the constraints? What is your recommendation? How much do you estimate this project will cost Acie?

13. A political candidate wants to make a mass mailing of some literature to counteract some nasty remarks his opponent has recently made. Five mailing lists have been identified that contain names and addresses of voters our candidate might like to reach. Each list may be purchased for a price. A partial list cannot be purchased. The numbers of names each list contains in each of four professions are listed below.

Mailing List	Names on Each List (in 1000's) by Profession				Cost of List
	Law	Health	Business Executives	Craft Professionals	
1	28	4	7	2	41,000
2	9	29	11	3	52,000
3	6	3	34	18	61,000
4	2	4	6	20	32,000
5	8	9	12	14	43,000
Desired Coverage	20	18	22	20	

Our candidate has estimated how many voters he wants to reach in each profession. This is listed in the row “Desired Coverage”. Having a more limited budget than the opponent, our candidate does not want to spend any more than he has to in order to “do the job”.

- a) How many decision variables would you need to model this problem?
 - b) How many constraints would you need to model this problem?
 - c) Define the decision variables you would use and write the objective function.
 - d) Write a complete model formulation.
14. Your agency provides telephone consultation to the public from 7 a.m. to 8 p.m., five days a week. The telephone load on your agency is heaviest in the months around April 15 of each year. You would like to set up staffing procedures for handling this load during these busy months. Each telephone consultant you hire starts work each day at either 7, 8, 9, 10, or 11 a.m., works for four hours, is off for one hour, and then works for another four hours. A complication that has become more noteworthy in recent years is that an increasing fraction of the calls handled by your agency is from Spanish-speaking clients. Therefore, you must have some consultants who speak Spanish. You are able to hire two kinds of consultants: English-speaking only, and bilingual (i.e., both English- and Spanish-speaking). A bilingual consultant can handle English and Spanish calls equally well. It should not be surprising that a bilingual consultant costs 1.1 times as much as an English-only consultant. You have collected some data on the call load by hour of the day and language type, measured in consultants required, for one of your more important offices. These data are summarized below:

Hour of the day:	7	8	9	10	11	12	1	2	3	4	5	6	7
English load:	4	4	5	6	6	8	5	4	4	5	5	5	3
Spanish load:	5	5	4	3	2	3	4	3	2	1	3	4	4

For example, during the hour from 10 a.m. to 11a.m., you must have working at least three Spanish-speaking consultants plus at least six more who can speak English.

How many consultants of each type would you start at each hour of the day?

15. The well-known mail order company R. R. Bean staffs its order-taking phone lines seven days per week. Each staffer costs \$100 per day and can work five consecutive days per week. An important question is: Which five-day interval should each staffer work? One of the staffers is pursuing an MBA degree part-time and, as part of her coursework, developed the following model specific to R. R. Bean's staffing requirements.

```

MIN=500 * M + 500 * T + 500 * W + 500 * R + 500 * F
      + 500 * S + 500 * N;
[R1] M           + R   + F   + S   + N >= 6 ;
[R2] M   + T           + F   + S   + N >= 7 ;
[R3] M   + T   + W           + S   + N >= 11;
[R4] M   + T   + W   + R           + N >= 9 ;
[R5] M   + T   + W   + R   + F           >= 11;
[R6]           T   + W   + R   + F   + S           >= 9;
[R7]           W   + R   + F   + S   + N >= 10;
END

```

Note that M denotes the number of staffers starting on Monday, T the number starting on Tuesday, etc. $R1$, $R2$, etc., simply serve as row identifiers.

- What is the required staffing level on Wednesday (not the number to hire starting on Wednesday, which is a harder question)?
- Suppose you can hire people on a 3-day-per-week part-time schedule to work the pattern consisting of the three consecutive days, Wednesday, Thursday, Friday. Because of training, turnover, and productivity considerations of part-timers, you figure the daily cost of these part-timers will be \$105 per day. Show how this additional option would be added to the model above.
- Do you think the part-time option above might be worth using?
- When the above staffing requirements are met, there will nevertheless be some customer calls that are lost, because of the chance all staffers may be busy when a prospective customer calls. A fellow from marketing who is an expert on customer behavior and knows a bit of queuing theory estimates having an additional staffer on duty on any given day beyond the minimum specified in the model above is worth \$75. More than one above the minimum is of no additional value. For example, if the minimum number of staffers required on a day is 8, but there are actually 10 on duty, then the better service will generate \$75 of additional revenue. A third fellow, who is working on an economics degree part-time at Freeport Community College, argues that, because the \$75 per day benefit is less than the \$100 per day cost of a staffer, the solution will be unaffected by the \$75 consideration. Is this fellow's argument correct?
- To double check your answer to (b), you decide to generalize the formulation to incorporate the \$75 benefit of one-person overstaffing. Define any additional decision variables needed and show (i) any modifications to the objective function and to existing constraints and (ii) any additional constraints. You need only illustrate for one day of the week.

16. In a typical state lottery, a player submits an entry by choosing six numbers without replacement (i.e., no duplicates) from the set of numbers $\{1, 2, 3, \dots, 44\}$. After all entries have been submitted, the state randomly chooses six numbers without replacement from the set $\{1, 2, 3, \dots, 44\}$. If all of your six numbers match those of the state, then you win a big prize. If only five out of six of your numbers match those of the state, then you win a medium size prize. If only four out of six of your numbers match those of the state, then you win a small prize. If several winners chose the same set of numbers, then the prize is split equally among them. You are thinking of submitting two entries to the next state lottery. A mathematician friend suggests the two entries: $\{2, 7, 1, 8, 28, 18\}$ and $\{3, 1, 4, 15, 9, 2\}$. Another friend suggests simply $\{1, 2, 3, 4, 5, 6\}$ and $\{7, 8, 9, 10, 11, 12\}$. Which pair of entries has the higher probability of winning some prize?
17. For most cutting stock problems, the continuous LP solution is close to the IP solution. In particular, you may notice that many cutting stock problems possess the “round-up” feature. For example, if the LP solution requires 11.6 sets, then that is a good indication that there is an IP solution that requires exactly 12 sets. Does this round-up feature hold in general? Consider for example a problem in which there is a single raw material of width 600 cm. There are three finished good widths: 300 cm, 200 cm, and 120 cm, with requirements respectively of 3, 5, , and 9 units.

Networks, Distribution and PERT/CPM

8.1 What's Special About Network Models

A subclass of models called network LPs warrants special attention for three reasons:

1. They can be completely described by simple, easily understood graphical figures.
2. Under typical conditions, they have naturally integer answers, and one may find a network LP a useful device for describing and analyzing the various shipment strategies.
3. They are frequently easier to solve than general LPs.

Physical examples that come to mind are pipeline or electrical transmission line networks. Any enterprise producing a product at several locations and distributing it to many warehouses and/or customers may find a network LP a useful device for describing and analyzing shipment strategies.

Although not essential, efficient specialized solution procedures may be used to solve network LPs. These procedures may be as much as 100 times faster than the general simplex method. Bradley, Brown, and Graves (1977) give a detailed description. Some of these specialized procedures were developed several years before the simplex method was developed for general LPs.

Figure 8.1 illustrates the network representing the distribution system of a firm using intermediate warehouses to distribute a product. The firm has two plants (denoted by A and B), three warehouses (denoted by X , Y , and Z), and four customer areas (denoted by 1, 2, 3, 4). The numbers adjacent to each node denote the availability of material at that node. Plant A , for example, has nine units available to be shipped. Customer 3, on the other hand, has -4 units meaning it needs to receive a shipment of four units.

The number above each arc is the cost per unit shipped along that arc. For example, if five of plant A 's nine units are shipped to warehouse Y , then a cost of $5 \times 2 = 10$ will be incurred as a direct result. The problem is to determine the amount shipped along each arc, so total costs are minimized and every customer has his requirements satisfied.

Figure 8.1 Three-Level Distribution Network

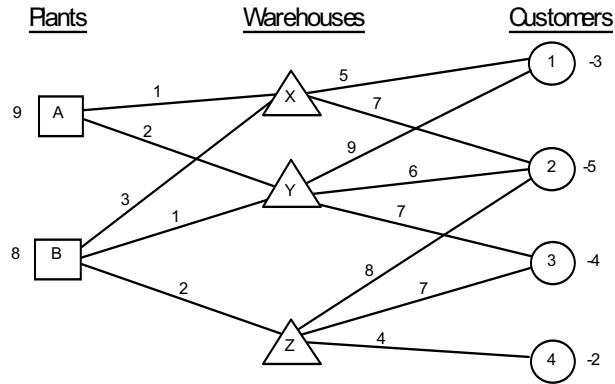

The essential condition on an LP for it to be a network problem is that it be representable as a network. There can be more than three levels of nodes, any number of arcs between any two nodes, and upper and lower limits on the amount shipped along a given arc.

With variables defined in an obvious way, the general LP describing this problem is:

$$\begin{aligned}
 \text{[COST] MIN} &= AX + 2 * AY + 3 * BX + BY + 2 * BZ + 5 * X1 \\
 &+ 7 * X2 + 9 * Y1 + 6 * Y2 + 7 * Y3 + 8 * Z2 + 7 * Z3 \\
 &+ 4 * Z4; \\
 \text{[A]} &AX + AY \leq 9; \\
 \text{[B]} &BX + BY + BZ \leq 8; \\
 \text{[X]} &- AX - BX + X1 + X2 = 0; \\
 \text{[Y]} &- AY - BY + Y1 + Y2 + Y3 = 0; \\
 \text{[Z]} &- BZ + Z2 + Z3 + Z4 = 0; \\
 \text{[C1]} &- X1 - Y1 = -3; \\
 \text{[C2]} &- X2 - Y2 - Z2 = -5; \\
 \text{[C3]} &- Y3 - Z3 = -4; \\
 \text{[C4]} &- Z4 = -2;
 \end{aligned}$$

There is one constraint for each node that is of a “sources = uses” form. Constraint 5, for example, is associated with warehouse Y and states that the amount shipped out minus the amount shipped in must equal 0.

A different view of the structure of a network problem is possible by displaying just the coefficients of the above constraints arranged by column and row. In the picture below, note that the apostrophes are placed every third row and column just to help see the regular patterns:

	A	A	B	B	B	X	X	Y	Y	Y	Z	Z	Z	
	X	Y	X	Y	Z	1	2	1	2	3	2	3	4	
COST:	1	2	3	1	2	5	7	9	6	7	8	7	4	MIN
A:	1	1	'			'			'					= 9
B:	'		1	1	1				'					= 8
X:	-1		-1			1	1		'					=
Y:		-1		-1		'		1	1	1				=
Z:	'	'	'	'	-1	'	'	'	'	'	1	1	1	=
C1:			'			-1		-1	'					= -3
C2:			'			'	-1		-1		-1	'		= -5
C3:	'	'	'	'	'	'	'	'	'	-1	'	-1	'	= -4
C4:			'			'		'			'		-1	= -2

You should notice the key feature of the constraint matrix of a network problem. That is, without regard to any bound constraints on individual variables, each column has exactly two nonzeros in the constraint matrix. One of these nonzeros is a +1, whereas the other is a -1. According to the convention we have adopted, the +1 appears in the row of the node from which the arc takes material, whereas the row of the node to which the arc delivers material is a -1. On a problem of this size, you should be able to deduce the optimal solution manually simply from examining Figure 8.1. You may check it with the computer solution below:

Variable	Value	Reduced Cost
AX	3.000000	0.000000
AY	3.000000	0.000000
BX	0.000000	3.000000
BY	6.000000	0.000000
BZ	2.000000	0.000000
X1	3.000000	0.000000
X2	0.000000	0.000000
Y1	0.000000	5.000000
Y2	5.000000	0.000000
Y3	4.000000	0.000000
Z2	0.000000	3.000000
Z3	0.000000	1.000000
Z4	2.000000	0.000000

Row	Slack or Surplus	Dual Price
COST	100.000000	-1.000000
A	3.000000	0.000000
B	0.000000	1.000000
X	0.000000	1.000000
Y	0.000000	2.000000
Z	0.000000	3.000000
C1	0.000000	6.000000
C2	0.000000	8.000000
C3	0.000000	9.000000
C4	0.000000	7.000000

This solution exhibits two pleasing features found in the solution to any network problem:

1. If the right-hand side coefficients (the capacities and requirements) are integer, then the variables will also be integer.
2. If the objective coefficients are integer, then the dual prices will also be integer.

We can summarize network LPs as follows:

1. Associated with each node is a number that specifies the amount of commodity available at that node (negative implies that commodity is required.)
2. Associated with each arc are:
 - a) a cost per unit shipped (which may be negative) over the arc,
 - b) a lower bound on the amount shipped over the arc (typically zero), and
 - c) an upper bound on the amount shipped over the arc (infinity in our example).

The problem is to determine the flows that minimize total cost subject to satisfying all the supply, demand, and flow constraints.

8.1.1 Special Cases

There are a number of common applications of LP models that are special cases of the standard network LP. The ones worthy of mention are:

1. *Transportation or distribution problems.* A two-level network problem, where all the nodes at the first level are suppliers, all the nodes at the second level are users, and the only arcs are from suppliers to users, is called a transportation, or distribution model.
2. *Shortest and longest path problems.* Suppose one is given the road network of the United States and wishes to find the shortest route from Bangor to San Diego. This is equivalent to a special case of a network or transshipment problem in which one unit of material is available at Bangor and one unit is required at San Diego. The cost of shipping over an arc is the length of the arc. Simple, fast procedures exist for solving this problem. An important first cousin of this problem, the longest route problem, arises in the analysis of PERT/CPM projects.
3. *The assignment problem.* A transportation problem in which the number of suppliers equals the number of customers, each supplier has one unit available, and each customer requires one unit, is called an assignment problem. An efficient, specialized procedure exists for its solution.
4. *Maximal flow.* Given a directed network with an upper bound on the flow on each arc, one wants to find the maximum that can be shipped through the network from some specified origin, or source node, to some other destination, or sink node. Applications might be to determine the rate at which a building can be evacuated or military material can be shipped to a distant trouble spot.

8.2 PERT/CPM Networks and LP

Program Evaluation and Review Technique (PERT) and Critical Path Method (CPM) are two closely related techniques for monitoring the progress of a large project. A key part of PERT/CPM is calculating the critical path. That is, identifying the subset of the activities that must be performed exactly as planned in order for the project to finish on time.

We will show that the calculation of the critical path is a very simple network LP problem, specifically, a longest path problem. You do not need this fact to efficiently calculate the critical path, but it is an interesting observation that becomes useful if you wish to examine a multitude of “crashing” options for accelerating a tardy project.

In the table below, we list the activities involved in the simple, but nontrivial, project of building a house. An activity cannot be started until all of its predecessors are finished:

Activity	Mnemonic	Activity Time	Predecessors (Mnemonic)
Dig Basement	DIG	3	—
Pour Foundation	FOUND	4	DIG
Pour Basement Floor	POURB	2	FOUND
Install Floor Joists	JOISTS	3	FOUND
Install Walls	WALLS	5	FOUND
Install Rafters	RAFTERS	3	WALLS, POURB
Install Flooring	FLOOR	4	JOISTS
Rough Interior	ROUGH	6	FLOOR
Install Roof	ROOF	7	RAFTERS
Finish Interior	FINISH	5	ROUGH, ROOF
Landscape	SCAPE	2	POURB, WALLS

In Figure 8.2, we show the so-called PERT (or activity-on-arrow) network for this project. We would like to calculate the minimum elapsed time to complete this project. Relative to this figure, the number of interest is simply the longest path from left to right in this figure. The project can be completed no sooner than the sum of the times of the successive activities on this path. Verify for yourself that the critical path consists of activities *DIG*, *FOUND*, *WALLS*, *RAFTERS*, *ROOF*, and *FINISH* and has length 27.

Even though this example can be worked out by hand, almost without pencil and paper, let us derive an LP formulation for solving this problem. Most people attempting this derivation will come up with one of two seemingly unrelated formulations.

The first formulation is motivated as follows. Let variables *DIG*, *FOUND*, etc. be either 1 or 0 depending upon whether activities *DIG*, *FOUND*, etc. are on or not on the critical path. The variables equal to one will define the critical path. The objective function will be related to the fact that we want to find the maximum length path in the PERT diagram.

Our objective is in fact:

$$\begin{aligned} \text{MAX} = & 3 * \text{DIG} + 4 * \text{FOUND} + 2 * \text{POURB} + 3 * \text{JOISTS} + \\ & 5 * \text{WALLS} + 3 * \text{RAFTERS} + 4 * \text{FLOOR} + 6 * \\ & \text{ROUGH} + 7 * \text{ROOF} + 5 * \text{FINISH} + 2 * \text{SCAPE}; \end{aligned}$$

Figure 8.2 Activity-on-Arc PERT/CPM Network

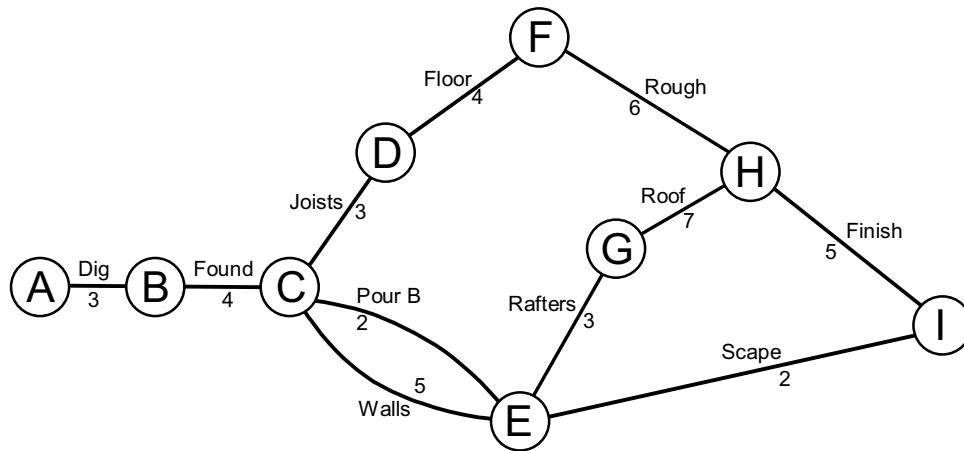

By itself, this objective seems to take the wrong point of view. We do not want to maximize the project length. However, if we specify the proper constraints, we shall see this objective will seek out the maximum length path in the PERT network. We want to use the constraints to enforce the following:

1. *DIG* must be on the critical path.
2. An activity can be on the critical path only if one of its predecessors is on the critical path. Further, if an activity is on a critical path, exactly one of its successors must be on the critical path, if it has successors.
3. Exactly one of *SCAPE* or *FINISH* must be on the critical path.

Convince yourself the following set of constraints will enforce the above:

- $DIG = -1;$
- $FOUND + DIG = 0;$
- $JOISTS - POURB - WALLS + FOUND = 0;$
- $FLOOR + JOISTS = 0;$
- $RAFTERS - SCAPE + POURB + WALLS = 0;$
- $ROUGH + FLOOR = 0;$
- $ROOF + RAFTERS = 0;$
- $FINISH + ROOF + ROOF = 0;$
- + $FINISH + SCAPE = +1;$

If you interpret the length of each arc in the network as the scenic beauty of the arc, then the formulation corresponds to finding the most scenic route by which to ship one unit from *A* to *I*.

The solution of the problem is:

Optimal solution found at step: 2
 Objective value: 27.00000

Variable	Value	Reduced Cost
DIG	1.000000	0.000000
FOUND	1.000000	0.000000
POURB	0.000000	3.000000
JOISTS	0.000000	0.000000
WALLS	1.000000	0.000000
RAFTERS	1.000000	0.000000
FLOOR	0.000000	0.000000
ROUGH	0.000000	2.000000
ROOF	1.000000	0.000000
FINISH	1.000000	0.000000
SCAPE	0.000000	13.000000

Row	Slack or Surplus	Dual Price
1	27.00000	1.000000
2	0.000000	6.000000
3	0.000000	-9.000000
4	0.000000	-5.000000
5	0.000000	-2.000000
6	0.000000	0.000000
7	0.000000	2.000000
8	0.000000	3.000000
9	0.000000	10.000000
10	0.000000	15.000000

Notice the variables corresponding to the activities on the critical path have a value of 1. What is the solution if the first constraint, $-DIG = -1$, is deleted?

It is instructive to look at the PICTURE of this problem in the following figure:

	F	P	O	W	A	F	R	I	S			
1:	3	4	2	3	5	3	4	6	7	5	2	MAX
2:	-1											= -1
3:	1	-1										=
4:		1	-1	-1								=
5:			1			-1						=
6:			1	1	-1						-1	=
7:						1	-1					=
8:					1			-1				=
9:							1	1	-1			=
10:									1	1		= 1

Notice that each variable has at most two coefficients in the constraints. When two, they are +1 and -1. This is the distinguishing feature of a network LP.

Now, let us look at the second possible formulation. The motivation for this formulation is to minimize the elapsed time of the project. To do this, realize that each node in the PERT network represents an event (e.g., as follows: *A*, start digging the basement; *C*, complete the foundation; and *I*, complete landscaping and finish interior).

Define variables *A*, *B*, *C*, ..., *H*, *I* as the time at which these events occur. Our objective function is then:

$$\text{MIN} = I - A;$$

These event times are constrained by the fact that each event has to occur later than each of its preceding events, at least by the amount of any intervening activity. Thus, we get one constraint for each activity:

$$\begin{array}{ll} B - A \geq 3; & ! \text{ DIG}; \\ C - B \geq 4; & ! \text{ FOUND}; \\ E - C \geq 2; & . \\ D - C \geq 3; & . \\ E - C \geq 5; & . \\ F - D \geq 4; & \\ G - E \geq 3; & \\ H - F \geq 6; & \\ H - G \geq 7; & \\ I - H \geq 5; & \\ I - E \geq 2; & \end{array}$$

The solution to this problem is:

Optimal solution found at step:	0	
Objective value:	27.00000	
Variable	Value	Reduced Cost
I	27.00000	0.000000
A	0.000000	0.000000
B	3.000000	0.000000
C	7.000000	0.000000
E	12.00000	0.000000
D	10.00000	0.000000
F	14.00000	0.000000
G	15.00000	0.000000
H	22.00000	0.000000
Row	Slack or Surplus	Dual Price
1	27.00000	1.000000
2	0.000000	-1.000000
3	0.000000	-1.000000
4	3.000000	0.000000
5	0.000000	0.000000
6	0.000000	-1.000000
7	0.000000	0.000000
8	0.000000	-1.000000
9	2.000000	0.000000
10	0.000000	-1.000000
11	0.000000	-1.000000
12	13.00000	0.000000

Notice that the objective function value equals the critical path length. We can indirectly identify the activities on the critical path by noting the constraints with nonzero dual prices. The activities corresponding to these constraints are on the critical path. This correspondence makes sense. The right-hand side of a constraint is the activity time. If we increase the time of an activity on the critical path, it should increase the project length and thus should have a nonzero dual price. What is the solution if the first variable, A , is deleted?

The PICTURE of the coefficient matrix for this problem follows:

	A	B	C	D	E	F	G	H	I	
1:	-1								1	MIN
2:	-1	1								> 3
3:		-1	1							> 4
4:			-1	1						> 2
5:			-1	1						> 3
6:			-1	1						> 5
7:				-1	1					> 4
8:					-1	1				> 3
9:						-1	1			> 6
10:							-1	1		> 7
11:								-1	1	> 5
12:					-1				1	> 2

Notice the PICTURE of this formulation is essentially the PICTURE of the previous formulation rotated ninety degrees. Even though these two formulations originally were seemingly unrelated, there is really an incestuous relationship between the two, a relationship that mathematicians politely refer to as duality.

8.3 Activity-on-Arc vs. Activity-on-Node Network Diagrams

Two conventions are used in practice for displaying project networks: (1) Activity-on-Arc (AOA) and (2) Activity-on-Node (AON). Our previous example used the AOA convention. The characteristics of the two are:

AON

- Each activity is represented by a node in the network.
- A precedence relationship between two activities is represented by an arc or link between the two.
- AON may be less error prone because it does not need dummy activities or arcs.

AOA

- Each activity is represented by an arc in the network.
- If activity X must precede activity Y , there are X leads into arc Y . The nodes thus represent events or “milestones” (e.g., “finished activity X ”). Dummy activities of zero length may be required to properly represent precedence relationships.
- AOA historically has been more popular, perhaps because of its similarity to Gantt charts used in scheduling.

An AON project with six activities is shown in Figure 8.3. The number next to each node is the duration of the activity. By inspection, you can discover that the longest path consists of activities A , C , E , and F . It has a length of 29. The corresponding AOA network for the same project is shown in

Figure 8.4. In the AOA network, we have enclosed the activity letters in circles above the associated arc. The unenclosed numbers below each arc are the durations of the activities. We have given the nodes, or milestones, arbitrary number designations enclosed in squares. Notice the dummy activity (the dotted arc) between nodes 3 and 4. This is because *a dummy activity will be required in an AOA diagram anytime that two activities (e.g., A and B) share some (e.g., activity D), but not all (e.g., activity C), successor activities*.

Figure 8.3 An Activity-on-Node Representation

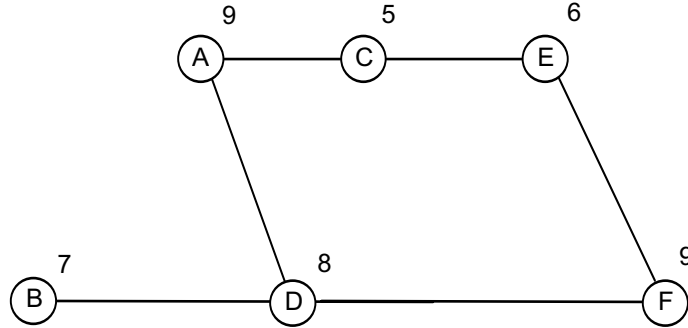
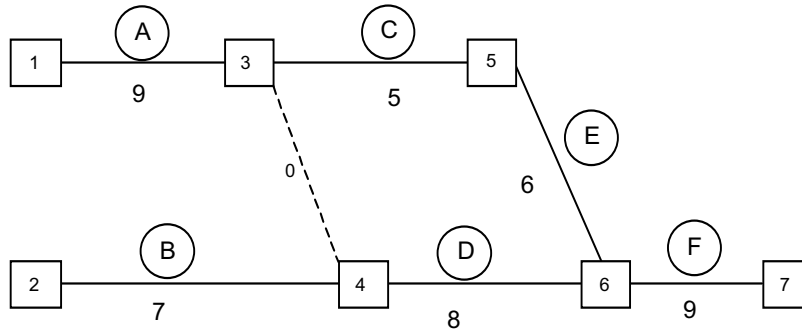

Figure 8.4 An Activity-on-Arc Representation



8.4 Crashing of Project Networks

Once the critical path length for a project has been identified, the next question invariably asked is: can we shorten the project? The process of decreasing the duration of a project or activity is commonly called crashing. For many construction projects, it is common for the customer to pay an incentive to the contractor for finishing the project in a shorter length of time. For example, in highway repair projects, it is not unusual to have incentives from \$5,000 to \$25,000 per day that the project is finished before a target date.

8.4.1 The Cost and Value of Crashing

There is value in crashing a project. In order to crash a project, we must crash one or more activities. Crashing an activity costs money. Deciding to crash an activity requires us to compare the cost of crashing that activity with the value of the resulting reduction in project length. This decision is frequently complicated by the fact that some negotiation may be required between the party that incurs the cost of crashing the activity (e.g., the contractor) and the party that enjoys the value of the crashed project (e.g., the customer).

8.4.2 The Cost of Crashing an Activity

An activity is typically crashed by applying more labor to it (e.g., overtime or a second shift). We might typically expect that using second-shift labor could cost 1.5 times as much per hour as first-shift labor. We might expect third-shift labor to cost twice as much as first-shift labor.

Consider an activity that can be done in six days if only first-shift labor is used and has a labor cost of \$6,000. If we allow the use of second-shift labor and thus work two shifts per day, the activity can be done in three days for a cost of $3 \times 1000 + 3 \times 1000 \times 1.5 = 7,500$. If third-shift labor is allowed, then the project can be done in two days by working three shifts per day and incurring a total of:

$$2 \times 1000 + 2 \times 1000 \times 1.5 + 2 \times 1000 \times 2 = \$9,000.$$

Thus, we get a crashing cost curve for the activity as shown in Figure 8.5:

Figure 8.5 Activity Crash Cost Curve

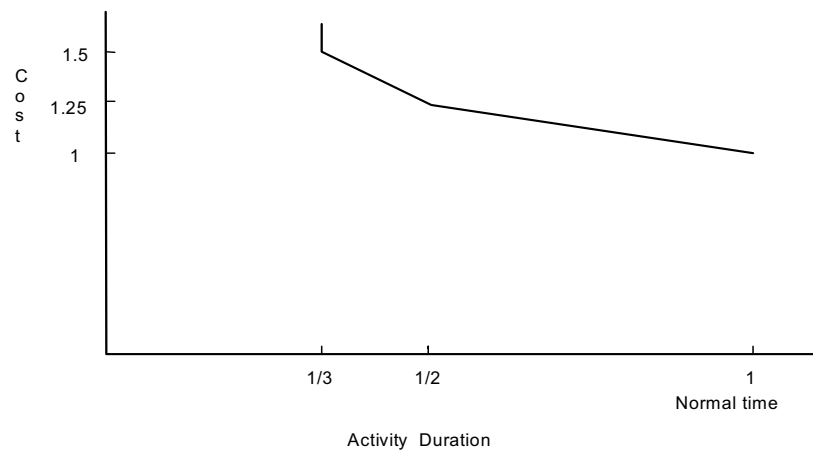

8.4.3 The Value of Crashing a Project

There are two approaches to deciding upon the amount of project crashing: (a) we simply specify a project duration time and crash enough to achieve this duration, or (b) we estimate the value of crashing it for various days. As an example of (a), in 1987 a new stadium was being built for the Montreal Expos baseball team. The obvious completion target was the first home game of the season.

As an example of (b), consider an urban expressway repair. What is the value per day of completing it early? Suppose that 6,000 motorists are affected by the repair project and each is delayed by 10 minutes each day because of the repair work (e.g., by taking alternate routes or by slower traffic). The total daily delay is $6,000 \times 10 = 60,000$ minutes = 1000 hours. If we assign an hourly cost of \$5/person \times hours, the social value of reducing the repair project by one day is \$5,000.

8.4.4 Formulation of the Crashing Problem

Suppose we have investigated the crashing possibilities for each activity or task in our previous project example. These estimates are summarized in the following table:

Activity	Predecessor	Normal duration (Days)	Minimum duration if crashed (Days)	\$/Day
A	—	9	5	5000
B	—	7	3	6000
C	A	5	3	4000
D	A,B	8	4	2000
E	C	6	3	3000
F	D,E	9	5	9000

For example, activity *A* could be done in five days rather than nine. However, this would cost us an extra $(9 - 5) \times 5000 = \$20,000$.

First, consider the simple case where we have a hard due date by which the project must be done. Let us say 22 days in this case. How would we decide which activities to crash? Activity *B* is the cheapest to crash per day. However, it is not on the critical path, so its low cost is at best just interesting.

Let us define:

EF_i = earliest finish time of activity *i*, taking into account any crashing that is done;

C_i = number of days by which activity *i* is crashed.

In words, the LP model will be:

Minimize Cost of crashing

subject to

For each activity *j* and each predecessor *i*:

earliest finish of *j* \geq earliest finish of predecessor *i* + actual duration of *j*;

For each activity *j*:

minimum duration for *j* if crashed \leq actual duration of *j* \leq normal duration for *j*.

A LINGO formulation is:

```
! Find optimal crashing for a project with a due date;
SETS:
  TASK: NORMAL, FAST, COST, EF, ACTUAL;
  PRED( TASK, TASK) ;;
ENDSETS
```

```

DATA:
  TASK, NORMAL, FAST, COST =
  A      9      5      5000
  B      7      3      6000
  C      5      3      4000
  D      8      4      2000
  E      6      3      3000
  F      9      5      9000;
PRED =
  A, C
  A, D
  B, D
  C, E
  D, F
  E, F;
DUEDATE = 22;
ENDDATA
!-----;
! Minimize the cost of crashing;
[OBJ] MIN = @SUM( TASK( I): COST( I)*( NORMAL( I) - ACTUAL( I)));
! For tasks with no predecessors...;
@FOR( TASK( J): EF( J) >= ACTUAL( J));
! and for those with predecessors;
@FOR( PRED( I, J):
  EF( J) >= EF( I) + ACTUAL( J);
);
! Bound the actual time;
@FOR( TASK( I):
  @BND( FAST(I), ACTUAL( I), NORMAL( I));
);
! Last task is assumed to be last in project;
EF( @SIZE( TASK)) <= DUEDATE;

```

Part of the solution is:

Global optimal solution found at step:		24
Objective value:		31000.00
Variable	Value	Reduced Cost
EF(A)	7.000000	0.000000
EF(B)	7.000000	0.000000
EF(C)	10.000000	0.000000
EF(D)	13.000000	0.000000
EF(E)	13.000000	0.000000
EF(F)	22.000000	0.000000
ACTUAL(A)	7.000000	0.000000
ACTUAL(B)	7.000000	-4000.000
ACTUAL(C)	3.000000	1000.000
ACTUAL(D)	6.000000	0.000000
ACTUAL(E)	3.000000	2000.000
ACTUAL(F)	9.000000	-2000.000

Thus, for an additional cost of \$31,000, we can meet the 22-day deadline.

Now, suppose there is no hard project due date, but we do receive an incentive payment of \$5000 for each day we reduce the project length. Define *PCRASH* = number of days the project is finished before the twenty-ninth day. Now, the formulation is:

```

! Find optimal crashing for a project with
  a due date and incentive for early completion;
SETS:
  TASK: NORMAL, FAST, COST, EF, ACTUAL;
  PRED( TASK, TASK)::;
ENDSETS
DATA:
  TASK, NORMAL, FAST, COST =
  A      9      5      5000
  B      7      3      6000
  C      5      3      4000
  D      8      4      2000
  E      6      3      3000
  F      9      5      9000;
  PRED =
  A, C
  A, D
  B, D
  C, E
  D, F
  E, F;
! Incentive for each day we beat the due date;
  INCENT = 5000;
  DUEDATE = 29;
ENDDATA
!-----;
! Minimize the cost of crashing
  less early completion incentive payment;
  [OBJ] MIN = @SUM( TASK( I): COST( I)*( NORMAL( I) - ACTUAL( I))
    - INCENT * PCRASH;
! For tasks with no predecessors...;
  @FOR( TASK( J): EF( J) >= ACTUAL( J));
! and for those with predecessors;
  @FOR( PRED( I, J):
    EF( J) >= EF( I) + ACTUAL( J);
  );
! Bound the actual time;
  @FOR( TASK( I):
    @BND( FAST(I), ACTUAL( I), NORMAL( I));
  );
! Last task is assumed to be last in project;
  EF( @SIZE( TASK)) + PCRASH = DUEDATE;

```

From the solution, we see we should crash it by five days to give a total project length of twenty-four days:

```
Global optimal solution found at step:          21
Objective value:                             -6000.000
Variable          Value          Reduced Cost
PCRASH            5.000000         0.0000000
EF( A)            7.000000         0.0000000
EF( B)            7.000000         0.0000000
EF( C)           12.000000         0.0000000
EF( D)           15.000000         0.0000000
EF( E)           15.000000         0.0000000
EF( F)           24.000000         0.0000000
ACTUAL( A)        7.000000         0.0000000
ACTUAL( B)        7.000000        -6000.000
ACTUAL( C)        5.000000        -1000.000
ACTUAL( D)        8.000000         0.0000000
ACTUAL( E)        3.000000         0.0000000
ACTUAL( F)        9.000000        -4000.000
```

The excess of the incentive payments over crash costs is \$6,000.

8.5 Resource Constraints in Project Scheduling

For many projects, a major complication is that there are a limited number of resources. The limited resources require you to do tasks individually that otherwise might be done simultaneously. Pritsker, Watters, and Wolfe (1969) gave a formulation representing resource constraints in project and jobshop scheduling problems. The formulation is based on the following key ideas: a) time is discrete rather than continuous (e.g., each period is a day), b) for every activity and every discrete period there is a 0/1 variable that is one if that activity starts in that period, and c) for every resource and period there is a constraint that enforces the requirement that the amount of resource required in that period does not exceed the amount available.

To illustrate, we take the example considered previously with shorter activity times, so the total number of periods is smaller:

```
! PERT/CPM project scheduling with resource constraints(PERTRSRD);
! Each activity is described by:
! a) duration, b) set of predecessor activities,
! c) set of resources or machines required;
! There is a limited number of each resource/machine.
! An activity cannot be started until:
! 1) all its predecessors have completed, and
! 2) resources/machines required are available;
!
! The precedence diagram is:
!
!      /FCAST\---SCHED---COSTOUT\
!     /      \
! FIRST      \
!     \      /
!      \SURVEY-PRICE-----FINAL;
SETS:
```

```

! There is a set of tasks with a given duration, and
  a start time to be determined;
  TASK: TIME, START;
! The precedence relations, the first task in the
  precedence relationship needs to be completed before the
  second task can be started;
  PRED( TASK, TASK);
  PERIOD;      ! There are a set of periods...;
  RESOURCE: CAP; ! and a set of resources, each with a capacity;
! Some operations need capacity in some department;
  TXR( TASK, RESOURCE): NEED;
! SX( I, T) = 1 if task I starts in period T;
  TXP( TASK, PERIOD): SX;
  RXP( RESOURCE, PERIOD);
ENDSETS

DATA:
! Upper limit on number of periods required
  to complete the project;
  PERIOD = 1..20;
! Task names and duration;
  TASK  TIME =
  FIRST   0
  FCAST   7
  SURVEY  2
  PRICE   1
  SCHED   3
  COSTOUT 2
  FINAL   4;
! The predecessor/successor combinations;
  PRED=  FIRST,FCAST,   FIRST,SURVEY,
        FCAST,PRICE,   FCAST,SCHED,   SURVEY,PRICE,
        SCHED,COSTOUT, PRICE,FINAL,   COSTOUT,FINAL;
! There are 2 departments, accounting and operations,
  with capacities...;
  RESOURCE = ACDEPT, OPNDEPT;
        CAP =  1,      1;
! How much each task needs of each resource;
        TXR,      NEED =
  FCAST,  OPNDEPT,  1
  SURVEY, OPNDEPT,  1
  SCHED,  OPNDEPT,  1
  PRICE,  ACDEPT,   1
  COSTOUT, ACDEPT,  1;
ENDDATA
!-----;
! Warning, this may be difficult to solve for more than a
  few dozen activities;
! Minimize start time of last task;
MIN = START( @SIZE( TASK));
! Start time for each task. SX(I,T) = 1 if activity I
  starts in period T;
@FOR( TASK( I):
  [DEFSTRT] START( I) = @SUM( PERIOD( T): T * SX( I, T));

```

```

);
@FOR( TASK( I):
! Each task must be started in some period;
[MUSTDO] @SUM( PERIOD( T): SX( I, T)) = 1;
! The SX vars are binary, i.e., 0 or 1;
@FOR( PERIOD( T): @BIN( SX( I, T)));
);
! Precedence constraints;
@FOR( PRED( I, J):
[PRECD] START( J) >= START( I) + TIME( I);
);
! Resource usage, for each resource R and period T;
@FOR( RXP( R, T):
! Sum over all tasks I that use resource R in period T;
[RSRUSE] @SUM( TXR( I, R):
@SUM( PERIOD( S) | S #GE# ( T - ( TIME( I) - 1)) #AND# S #LE# T:
NEED( I, R) * SX( I, S))) <= CAP( R);
);
END

```

When solved, we get a project length of 14. If there were no resource constraints, then the project length would be 13:

```

Global optimal solution found
Objective value:      14.00000
Variable             Value
START( FIRST)        1.000000
START( FCAST)        1.000000
START( SURVEY)       11.00000
START( PRICE)        13.00000
START( SCHED)        8.000000
START( COSTOUT)      11.00000
START( FINAL)        14.00000

```

8.6 Path Formulations

In many network problems, it is natural to think of a solution in terms of paths that material takes as it flows through the network. For example, in Figure 8.1, there are thirteen possible paths. Namely:

$$\begin{aligned}
 &A \rightarrow X \rightarrow 1, A \rightarrow X \rightarrow 2, A \rightarrow Y \rightarrow 1, A \rightarrow Y \rightarrow 2, A \rightarrow Y \rightarrow 3, B \rightarrow X \rightarrow 1, B \rightarrow X \rightarrow 2, \\
 &B \rightarrow Y \rightarrow 1, B \rightarrow Y \rightarrow 2, B \rightarrow Y \rightarrow 3, B \rightarrow Z \rightarrow 2, B \rightarrow Z \rightarrow 3, \\
 &B \rightarrow Z \rightarrow 4
 \end{aligned}$$

One can, in fact, formulate decision variables in terms of complete paths rather than just simple links, where the path decision variable corresponds to using a combination of links. This is a form of what is sometimes called a composite variable approach. The motivations for using the path approach are:

1. More complicated cost structures can be represented. For example, Geoffrion and Graves (1974) use the path formulation to represent “milling in transit” discount fare structures in shipping food and feed products.

2. Path-related restrictions can be incorporated. For example, regulations allow a truck driver to be on duty for at most 10 hours. Thus, in a truck routing network one would not consider paths longer than 10 hours. In a supply chain network, a path that is long may be prohibited because it may cause lead times to be too long.
3. The number of rows (constraints) in the model may be substantially less.
4. In integer programs where some, but not all, of the problem has a network structure, the path formulation may be easier to solve.

8.6.1 Example

Let us reconsider the first problem (Figure 8.1, page 142). Suppose shipments from A to X are made by the same carrier as shipments from X to 2. This carrier will give a \$1 per unit “milling-in-transit” discount for each unit it handles from both A to X and X to 2. Further, the product is somewhat fragile and cannot tolerate a lot of transportation. In particular, it cannot be shipped both over link $B \rightarrow X$ and $X \rightarrow 2$ or both over links $A \rightarrow Y$ and $Y \rightarrow 1$.

Using the notation AXI = number of units shipped from A to X to 1, etc., the path formulation is:

$$\begin{aligned}
 \text{MIN} = & 6 * \text{PAX1} + 7 * \text{PAX2} + 8 * \text{PAY2} \\
 & + 9 * \text{PAY3} + 8 * \text{PBX1} + 10 * \text{PBY1} \\
 & + 7 * \text{PBY2} + 8 * \text{PBY3} + 10 * \text{PBZ2} \\
 & + 9 * \text{PBZ3} + 6 * \text{PBZ4}; \\
 \text{[A]} & \text{PAX1} + \text{PAX2} + \text{PAY2} + \text{PAY3} \leq 9; \\
 \text{[B]} & \text{PBX1} + \text{PBY1} + \text{PBY2} + \text{PBY3} \\
 & + \text{PBZ2} + \text{PBZ3} + \text{PBZ4} \leq 8; \\
 \text{[C1]} & \text{PAX1} + \text{PBX1} + \text{PBY1} = 3; \\
 \text{[C2]} & \text{PAX2} + \text{PAY2} + \text{PBY2} + \text{PBZ2} = 5; \\
 \text{[C3]} & \text{PAY3} + \text{PBY3} + \text{PBZ3} = 4; \\
 \text{[C4]} & \text{PBZ4} = 2;
 \end{aligned}$$

Notice the cost of path $AX2 = 1 + 7 - 1 = 7$. In addition, paths $BX2$ and $AY1$ do not appear. This model has only six constraints as opposed to nine in the original formulation. The reduction in constraints arises from the fact that, in path formulations, one does not need the “sources = uses” constraints for intermediate nodes.

In general, the path formulation will have fewer rows, but more decision variables than the corresponding network LP model.

When we solve, we get:

Objective value=	97.0000
Variable	Value
PAX1	3.000000
PAX2	3.000000
PBY2	2.000000
PBY3	4.000000
PBZ4	2.000000

This is cheaper than the previous solution, because the three units shipped over path $AX2$ go for \$1 per unit less.

A path formulation need not have a naturally integer solution. If the path formulation, however, is equivalent to a network LP, then it will have a naturally integer solution.

The path formulation is popular in long-range forest planning. See, for example, Davis and Johnson (1986), where it is known as the “Model I” approach. The standard network LP based

formulation is known as the “Model II” approach. In a forest planning Model II, a link in the network represents a decision to plant an acre of a particular kind of tree in some specified year and harvest it in some future specified year. A node represents a specific harvest and replant decision. A decision variable in Model I is a complete prescription of how to manage (i.e., harvest and replant) a given piece of land over time. Some Model I formulations in forest planning may have just a few hundred constraints, but over a million decision variables or paths.

There is a generalization of the path formulation to arbitrary linear programs, known as Fourier/Motzkin/Dines elimination, see for example Martin (1999) and Dantzig (1963). The transformation of a network LP to the path formulation involves eliminating a particular node (constraint), by generating a new variable for every combination of input arc and output arc incident to the node. A constraint in an arbitrary LP can be eliminated if it is first converted to a constraint with a right-hand side of zero and then a new variable is generated for every combination of positive and negative coefficient in the constraint. The disadvantage of this approach is that even though the number of constraints is reduced to one, the number of variables may grow exponentially with the number of original constraints.

A variable corresponding to a path in a network is an example of a composite variable, a general approach that is sometimes useful for representing complicated/ing constraints. A composite variable is one that represents a feasible combination of two or more original variables. The complicating constraints are represented implicitly by generating only those composite variables that correspond to feasible combinations and values of the original variables.

8.7 Path Formulations of Undirected Networks

In many communications networks, the arcs have capacity, but are undirected. For example, when you are carrying on a phone conversation with someone in a distant city, the conversation uses capacity on all the links in your connection. However, you cannot speak of a direction of flow of the connection.

A major concern for a long distance communications company is the management of its communications network. This becomes particularly important during certain holidays, such as Mother’s Day. Not only does the volume of calls increase on these days, but also the pattern of calls changes dramatically from the business-oriented traffic during weekdays in the rest of the year. A communications company faces two problems: (a) the design problem. That is, what capacity should be installed on each link? As well as, (b) the operations problem. That is, given the installed capacity, how are demands best routed? The path formulation is an obvious format for modeling an undirected network. The following illustrates the operational problem.

Consider the case of a phone company with the network structure shown in Figure 8.6:

Figure 8.6 Phone Company Network Structure

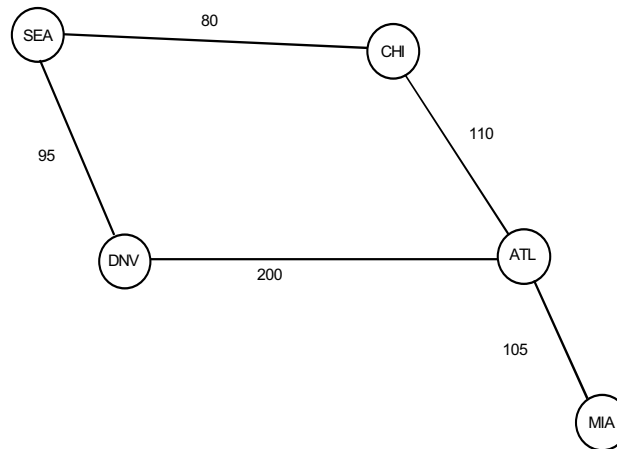

The number next to each arc is the number of calls that can be in progress simultaneously along that arc. If someone in *MIA* tries to call his mother in *SEA*, the phone company must first find a path from *MIA* to *SEA* such that each arc on that path is not at capacity. It is quite easy to inefficiently use the capacity. Suppose there is a demand for 110 calls between *CHI* and *DNV* and 90 calls between *ATL* and *SEA*. Further, suppose all of these calls were routed over the *ATL, DNV* link. Now, suppose we wish to make a call between *MIA* and *SEA*. Such a connection is impossible because every path between the two contains a saturated link (i.e., either *ATL, DNV* or *CHI, ATL*). However, if some of the 110 calls between *CHI* and *DNV* were routed over the *CHI, SEA, DNV* links, then one could make calls between *MIA* and *SEA*. In conventional voice networks, a call cannot be rerouted once it has started. In packet switched data networks and, to some extent, in cellular phone networks, some rerouting is possible.

8.7.1 Example

Suppose during a certain time period the demands in the table below occur for connections between pairs of cities:

	DNV	CHI	ATL	MIA
SEA	10	20	38	33
DNV		42	48	23
CHI			90	36
ATL				26

Which demands should be satisfied and via what routes to maximize the number of connections satisfied?

Solution. If we use the path formulation, there will be two paths between every pair of cities except *ATL* and *MIA*. We will use the notation $P1_{ij}$ for number of calls using the shorter or more northerly path between cities i and j , and $P2_{ij}$ for the other path, if any. There will be two kinds of constraints:

- 1) a capacity constraint for each link, and
- 2) an upper limit on the calls between each pair of cities, based on available demand.

A formulation is:

```

! Maximize calls carried;
MAX = P1MIAATL + P1MIADNV + P2MIADNV
      + P1MIASEA + P2MIASEA + P1MIACHI
      + P2MIACHI + P1ATLDNV + P2ATLDNV
      + P1ATLSEA + P2ATLSEA + P1ATLCHI
      + P2ATLCHI + P1DINVSEA + P2DINVSEA
      + P1DINVCHI + P2DINVCHI + P1SEACHI
      + P2SEACHI;
! Capacity constraint for each link;
[KATLMIA] P1MIAATL + P1MIADNV + P2MIADNV
          + P1MIASEA + P2MIASEA + P1MIACHI
          + P2MIACHI <= 105;
[KATLDNV] P1MIADNV + P1MIASEA + P1MIACHI
          + P1ATLDNV + P1ATLSEA + P1ATLCHI
          + P2DINVSEA + P2DINVCHI + P2SEACHI <= 200;
[KDINVSEA] P2MIADNV + P1MIASEA + P1MIACHI
           + P2ATLDNV + P1ATLSEA + P1ATLCHI
           + P1DINVSEA + P1DINVCHI + P2SEACHI <= 95;
[KSEACHI] P2MIADNV + P2MIASEA + P1MIACHI
          + P2ATLDNV + P2ATLSEA + P1ATLCHI
          + P2DINVSEA + P1DINVCHI + P1SEACHI <= 80;
[KATLCHI] P2MIADNV + P2MIASEA + P2MIACHI
          + P2ATLDNV + P2ATLSEA + P2ATLCHI
          + P2DINVSEA + P2DINVCHI + P2SEACHI <= 110;
! Demand constraints for each city pair;
[DMIAATL] P1MIAATL <= 26;
[DMIADNV] P1MIADNV + P2MIADNV <= 23;
[DMIASEA] P1MIASEA + P2MIASEA <= 33;
[DMIACHI] P1MIACHI + P2MIACHI <= 36;
[DATLDNV] P1ATLDNV + P2ATLDNV <= 48;
[DATLSEA] P1ATLSEA + P2ATLSEA <= 38;
[DATLCHI] P1ATLCHI + P2ATLCHI <= 90;
[DDINVSEA] P1DINVSEA + P2DINVSEA <= 10;
[DDINVCHI] P1DINVCHI + P2DINVCHI <= 42;
[DSEACHI] P1SEACHI + P2SEACHI <= 20;

```

When this formulation is solved, we see we can handle 322 out of the total demand of 366 calls:

```

Optimal solution found at step:      11
Objective value:                    322.0000

Variable      Value      Reduced Cost
P1MIAATL      26.00000      0.000000
P1MIADNV      23.00000      0.000000
P2MIADNV       0.00000      2.000000
P1MIASEA       0.00000      0.000000
P2MIASEA       0.00000      0.000000
P1MIACHI      25.00000      0.000000
P2MIACHI       0.00000      0.000000
P1ATLDNV      48.00000      0.000000
P2ATLDNV       0.00000      2.000000
P1ATLSEA      38.00000      0.000000
P2ATLSEA       0.00000      0.000000
P1ATLCHI      23.00000      0.000000
P2ATLCHI      67.00000      0.000000
P1DNVSEA       3.50000      0.000000
P2DNVSEA       6.50000      0.000000
P1DNVCHI       5.50000      0.000000
P2DNVCHI      36.50000      0.000000
P1SEACHI      20.00000      0.000000
P2SEACHI       0.00000      2.000000

      Row      Slack or Surplus      Dual Price
      1      322.00000      1.000000
KATLMIA      31.00000      0.000000
KATLDNV       0.00000      0.000000
KDNVSEA       0.00000      1.000000
KSEACHI       0.00000      0.000000
KATLCHI       0.00000      1.000000
DMIAATL       0.00000      1.000000
DMIADNV       0.00000      1.000000
DMIASEA      33.00000      0.000000
DMIACHI      11.00000      0.000000
DATLDNV       0.00000      1.000000
DATLSEA       0.00000      0.000000
DATLCHI       0.00000      0.000000
DDNVSEA       0.00000      0.000000
DDNVCHI       0.00000      0.000000
DSEACHI       0.00000      1.000000

```

Verify that the demand not carried is *MIA-CHI*: 11 and *MIA-SEA*: 33. Apparently, there are a number of alternate optima.

8.8 Double Entry Bookkeeping: A Network Model of the Firm

Authors frequently like to identify who was the first to use a given methodology. A contender for the distinction of formulating the first network model is Fra Luca Pacioli. In 1594, while director of a Franciscan monastery in Italy, he published a description of the accounting convention that has come to be known as double entry bookkeeping. From the perspective of networks, each double entry is an arc in a network.

To illustrate, suppose you start up a small dry goods business. During the first two weeks, the following transactions occur:

- CAP* 1) You invest \$50,000 of capital in cash to start the business.
- UR* 2) You purchase \$27,000 of product on credit from supplier *S*.
- PAY* 3) You pay \$13,000 of your accounts payable to supplier *S*.
- SEL* 4) You sell \$5,000 of product to customer *C* for \$8,000 on credit.
- REC* 5) Customer *C* pays you \$2,500 of his debt to you.

In our convention, liabilities and equities will typically have negative balances. For example, the initial infusion of cash corresponds to a transfer (an arc) from the equity account (node) to the cash account, with a flow of \$50,000. The purchase of product on credit corresponds to an arc from the accounts payable account node to the raw materials inventory account, with a flow of \$27,000. Paying \$13,000 to the supplier corresponds to an arc from the cash account to the accounts payable account, with a flow of \$13,000. Figure 8.7 illustrates.

Figure 8.7 Double Entry Bookkeeping as a Network Model

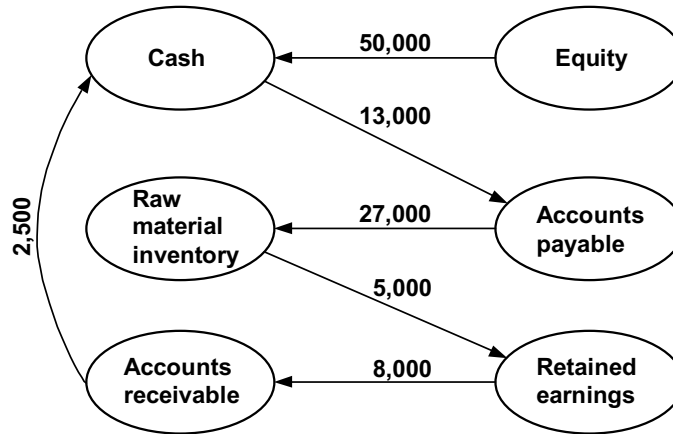

8.9 Extensions of Network LP Models

There are several generalizations of network models that are important in practice. These extensions share two features in common with true network LP models, namely:

- They can be represented graphically.
- Specialized, fast solution procedures exist for several of these generalizations.

The one feature typically not found with these generalizations is:

- Solutions are usually not naturally integer, even if the input data are integers.

The important generalizations we will consider are:

1. *Networks with Gains*. Sometimes called generalized networks, this generalization allows a specified gain or loss of material as it is shipped from one node to another. Structurally, these problems are such that every column has at most two nonzeros in the constraint matrix. However, the requirement that these coefficients be +1 and -1 is relaxed. Specialized procedures, which may be twenty times faster than the regular simplex method, exist for solving these problems.
Examples of “shipments” with such gains or losses are: investment in an interest-bearing account, electrical transmission with loss, natural gas pipeline shipments where the pipeline pumps burn natural gas from the pipeline, and work force attrition. Stroup and Wollmer (1992) show how a network with gains model is useful in the airline industry for deciding where to purchase fuel and where to ferry fuel from one stop to another. Truemper (1976) points out, if the network with gains has no circuits when considered as an undirected network, then it can be converted to a pure network model by appropriate scaling.
2. *Undirected Networks*. In communications networks, there is typically no direction of shipment. The arcs are undirected.
3. *Multicommodity Networks*. In many distribution situations, there are multiple commodities moving through the network, all competing for scarce network capacity. Each source may produce only one of the commodities and each destination, or sink, may accept only one specific commodity.
4. *Leontief Flow*. In a so-called Leontief input-output model (see Leontief, 1951), each activity uses several commodities although it produces only one commodity. For example, one unit of automotive production may use a half ton of steel, 300 pounds of plastic, and 100 pounds of glass. Material Requirements Planning (MRP) models have the same feature. If each output required only one input, then we would simply have a network with gains. Special purpose algorithms exist for solving Leontief Flow and MRP models. See, for example, Jeroslow, Martin, Rardin, and Wang (1992).
5. *Activity/Resource Diagrams*. If Leontief flow models are extended, so each activity can have not only several inputs, but also several outputs, then one can in fact represent arbitrary LPs. We call the obvious extension of the network diagrams to this case an activity/resource diagram.

8.9.1 Multicommodity Network Flows

In a network LP, one assumption is a customer is indifferent, except perhaps for cost, to the source from which his product was obtained. Another assumption is that there is a single commodity flowing through the network. In many network-like situations, there are multiple distinct commodities flowing through the network. If each link has infinite capacity, then an independent network flow LP could be solved for each commodity. However, if a link has a finite capacity that applies to the sum of all commodities flowing over that link, then we have a multicommodity network problem.

The most common setting for multicommodity network problems is in shipping. The network might be a natural gas pipeline network and the commodities might be different fuels shipped over the network. In other shipping problems, such as traffic assignment or overnight package delivery, each origin/destination pair constitutes a commodity.

The crucial feature is identity of the commodities must be maintained throughout the network. That is, customers care which commodity gets delivered. An example is a metals supply company that ships

aluminum bars, stainless steel rings, steel beams, etc., all around the country, using a single limited capacity fleet of trucks.

In general form, the multicommodity network problem is defined as:

- D_{ik} = demand for commodity k at node i , with negative values denoting supply;
- C_{ijk} = cost per unit of shipping commodity k from node i to node j ;
- U_{ij} = capacity of the link from node i to node j .

We want to find:

X_{ijk} = amount of commodity k shipped from node i to node j , so as to:

$$\min \sum_i \sum_j \sum_k c_{ijk} x_{ijk}$$

subject to:

For each commodity k and node t :

$$\sum_i x_{itk} = D_{tk} + \sum_j x_{tjk}$$

For each link i, j :

$$\sum_k x_{ijk} \leq U_{ij}$$

8.9.2 Reducing the Size of Multicommodity Problems

If the multiple commodities correspond to origin destination pairs and the cost of shipping a unit over a link is independent of the final destination, then you can aggregate commodities over destinations. That is, you need identify a commodity only by its origin, not by both origin and destination. Thus, you have as many commodities as there are origins, rather than (number of origins) \times (number of destinations). For example, in a 100-city problem, using this observation, you would have only 100 commodities, rather than 10,000 commodities.

One of the biggest examples of multicommodity network problems in existence are the Patient Distribution System models developed by the United States Air Force for planning for transport of sick or wounded personnel.

8.9.3 Multicommodity Flow Example

You have decided to compete with Federal Express by offering “point to point” shipment of materials. Starting small, you have identified six cities as the ones you will first serve. The matrix below represents the average number of tons potential customers need to move between each origin/destination pair per day. For example, people in city 2 need to move four tons per day to city 3:

	Demand in tons, $D(i, j)$, by O/D pair						Cost/ton shipped, $C(i, j)$, by link						Capacity in tons, $U(i, j)$, By link						
	To:	1	2	3	4	5	6	1	2	3	4	5	6	1	2	3	4	5	6
From	1	0	5	9	7	0	4	0	4	5	8	9	9	0	2	3	2	1	20
	2	0	0	4	0	1	0	3	0	3	2	4	6	0	0	2	8	3	9
	3	0	0	0	0	0	0	5	3	0	2	3	5	3	0	0	1	3	9
	4	0	0	0	0	0	0	7	3	3	0	5	6	5	4	6	0	5	9
	5	0	4	0	2	0	8	8	5	3	6	0	3	1	0	2	7	0	9
	6	0	0	0	0	0	0	9	7	4	5	5	0	9	9	9	9	9	0

Rather than use a hub system as Federal Express does, you will ship the materials over a regular directed network. The cost per ton of shipping from any node i to any other node j is denoted by $C(i, j)$. There is an upper limit on the number of tons shipped per day over any link in the network of $U(i, j)$. This capacity restriction applies to the total amount of all goods shipped over that link, regardless of origin or destination. Note $U(i, j)$ and $C(i, j)$ apply to links in the network, whereas $D(i, j)$ applies to origin/destination pairs. This capacity restriction applies only to the directed flow. That is, $U(i, j)$ need not equal $U(j, i)$. It may be that none of the goods shipped from origin i to destination j moves over link (i, j) . It is important goods maintain their identity as they move through the network. Notice city 6 looks like a hub. It has high capacity to and from all other cities.

In order to get a compact formulation, we note only three cities, 1, 2, and 5, are suppliers. Thus, we need keep track of only three commodities in the network, corresponding to the city of origin for the commodity. Define:

X_{ijk} = tons shipped from city i to city j of commodity k .

The resulting formulation is:

```

MODEL:
! Keywords: multi-commodity, network flow, routing;
! Multi-commodity network flow problem;
SETS:
! The nodes in the network;
  NODES/1..6/;;
! The set of nodes that are origins;
  COMMO(NODES)/1, 2, 5/;;
  EDGES(NODES, NODES): D, C, U, V;
  NET(EDGES, COMMO): X;
ENDSETS
DATA:
! Demand: amount to be shipped from
  origin(row) to destination(col);
D = 0 5 9 7 0 4
    0 0 4 0 1 0
    0 0 0 0 0 0
    0 0 0 0 0 0
    0 4 0 2 0 8
    0 0 0 0 0 0;
! Cost per unit shipped over a arc/link;
C = 0 4 5 8 9 9
    3 0 3 2 4 6
    5 3 0 2 3 5
    7 3 3 0 5 6
    8 5 3 6 0 3
    9 7 4 5 5 0;
! Upper limit on amount shipped on each link;
U = 0 2 3 2 1 20
    0 0 2 8 3 9
    3 0 0 1 3 9
    5 4 6 0 5 9
    1 0 2 7 0 9
    9 9 9 9 9 0;

```

```

! Whether an arc/link exists or not;
! V = 0 if U = 0;
! V = 1 otherwise;
V = 0 1 1 1 1 1
    0 0 1 1 1 1
    1 0 0 1 1 1
    1 1 1 0 1 1
    1 0 1 1 0 1
    1 1 1 1 1 0;
ENDDATA

! Minimize shipping cost over all links;
MIN = @SUM( NET(I, J, K): C(I, J) * X(I, J, K));

! This is the balance constraint. There are two cases:
! Either the node that needs to be balanced is not a supply,
! in which case the sum of incoming amounts
! minus the sum of outgoing amounts must equal
! the demand for that commodity for that city;
! or where the node is a supply,
! the sum of incoming minus outgoing amounts must equal
! the negative of the sum of the demand for the commodity
! that the node supplies;
@FOR(COMMO(K): @FOR(NODES(J)|J #NE# K:
    @SUM(NODES(I): V(I, J) * X(I, J, K) - V(J, I) * X(J, I, K))
    = D(K, J);
);
@FOR(NODES(J)|J #EQ# K:
    @SUM(NODES(I): V(I, J) * X(I, J, K) - V(J, I) * X(J, I, K))
    = -@SUM( NODES(L): D(K, L)););

! This is a capacity constraint;
@FOR(EDGES(I, J)|I #NE# J:
    @SUM(COMMO(K): X(I, J, K)) <= U(I, J);
);

END

```

Notice there are 3 (commodities) × 6 (cities) = 18 balance constraints. If we instead identified goods by origin/destination combination rather than just origin, there would be 9 × 6 = 54 balance constraints. Solving, we get:

Optimal solution found at step:	56	
Objective value:	361.0000	
Variable	Value	Reduced Cost
X(1, 2, 1)	2.000000	0.000000
X(1, 3, 1)	3.000000	0.000000
X(1, 4, 1)	2.000000	0.000000
X(1, 5, 1)	1.000000	0.000000
X(1, 6, 1)	17.000000	0.000000
X(2, 3, 2)	2.000000	0.000000
X(2, 4, 2)	2.000000	0.000000
X(2, 5, 2)	1.000000	0.000000
X(3, 4, 5)	1.000000	0.000000
X(4, 2, 5)	4.000000	0.000000
X(4, 3, 2)	2.000000	0.000000

X(5, 3, 1)	1.000000	0.0000000
X(5, 3, 5)	1.000000	0.0000000
X(5, 4, 5)	5.000000	0.0000000
X(5, 6, 5)	8.000000	0.0000000
X(6, 2, 1)	3.000000	0.0000000
X(6, 3, 1)	5.000000	0.0000000
X(6, 4, 1)	5.000000	0.0000000

Notice, because of capacity limitations on other links, the depot city (6) is used for many of the shipments.

8.9.4 Fleet Routing and Assignment

An important problem in the airline and trucking industry is fleet routing and assignment. Given a set of shipments or flights to be made, the routing part is concerned with the path each vehicle takes. This is sometimes called the FTL(Full Truck Load) routing problem. The assignment part is of interest if the firm has several different fleets of vehicles available. Then the question is what type of vehicle is assigned to each flight or shipment. We will describe a simplified version of the approach used by Subramanian et al. (1994) to do fleet assignment at Delta Airlines. A similar approach has been used at US Airways by Kontogiorgis and Acharya (1999).

To motivate things, consider the following set of flights serving Chicago (ORD), Denver (DEN), and Los Angeles (LAX) that United Airlines once offered on a typical weekday:

Daily Flight Schedule					
Flight	City	City		Time	
		Depart	Arrive	Depart	Arrive
1	221	ORD	DEN	0800	0934
2	223	ORD	DEN	0900	1039
3	274	LAX	DEN	0800	1116
4	105	ORD	LAX	1100	1314
5	228	DEN	ORD	1100	1423
6	230	DEN	ORD	1200	1521
7	259	ORD	LAX	1400	1609
8	293	DEN	LAX	1400	1510
9	412	LAX	ORD	1400	1959
10	766	LAX	DEN	1600	1912
11	238	DEN	ORD	1800	2121

This schedule can be represented by the network in Figure 8.8. The diagonal lines from upper left to lower right represent flight arrivals. The diagonal lines from lower left to upper right represent departures. To complete the diagram, we need to add the lines connecting each flight departure to each flight arrival. The thin line connecting the departure of Flight 274 from LAX to the arrival of Flight 274 in Denver illustrates one of the missing lines. If the schedule repeats every day, it is reasonable to have the network have a backloop for each city, as illustrated for LAX. To avoid clutter, these lines have not been added.

Figure 8.8 A Fleet Routing Network

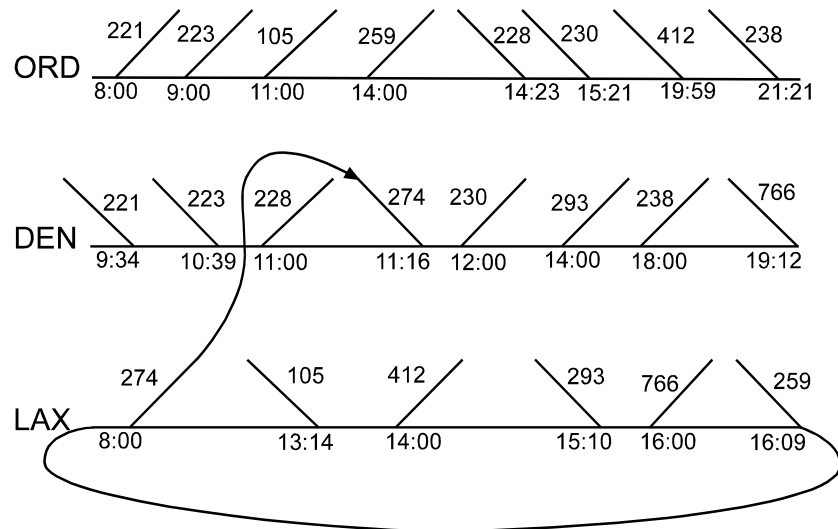

Perhaps the obvious way of interpreting this as a network problem is as follows:

- Each diagonal line (with the connection to its partner) constitutes a variable, corresponding to a flight;
- each horizontal line or backloop corresponds to a decision variable representing the number of aircraft on the ground;
- each point of either an arrival or a departure constitutes a node, and the model will have a constraint saying, in words:

$$\begin{aligned}
 &(\text{no. of aircraft on the ground at this city at this instant}) + (\text{arrivals at this instant}) \\
 &= (\text{no. of departures from this city at this instant}) + (\text{no. of aircraft on the ground after this instant}).
 \end{aligned}$$

With this convention, there would be 22 constraints (8 at *ORD*, 8 at *DEN*, and 6 at *LAX*), and 33 variables (11 flight variables and 22 ground variables). The number of constraints and variables can be reduced substantially if we make the observation that the feasibility of a solution is not affected if, for each city:

- Each arrival is delayed until the first departure after that arrival.
- Each departure is advanced (made earlier) to the most recent departure just after an arrival.

Thus, the only nodes required are when a departure immediately follows an arrival.

If we have a fleet of just one type of aircraft, we probably want to know what is the minimum number of aircrafts needed to fly this schedule. In words, our model is:

Minimize number of aircraft on the ground overnight
 (That is the only place they can be, given the flight schedule)
 subject to
 source of aircraft = use of aircraft at each node of the network
 and each flight must be covered.

Taking all the above observations into account gives the following formulation of a network LP. Note the G variables represent the number of aircraft on the ground at a given city just after a specified instant:

```

! Fleet routing with a single plane type;
! Minimize number of planes on ground overnight;
MIN = GC2400 + GD2400 + GL2400;
! The plane(old) conservation constraints;
! Chicago at 8 am, sources - uses = 0;
GC2400 - F221 - F223 - F105 - F259 - GC1400 = 0;
! Chicago at midnight;
GC1400 + F228 + F230 + F412 + F238 - GC2400 = 0;
! Denver at 11 am;
GD2400 + F221 + F223 - F228 - GD1100 = 0;
! Denver at high noon;
GD1100 + F274 - F230 - F293 - F238 - GD1800 = 0;
! Denver at midnight;
GD1800 + F766 - GD2400 = 0;
! LA at 8 am;
GL2400 - F274 - GL0800 = 0;
! LA at 1400;
GL0800 + F105 - F412 - GL1400 = 0;
! LA at 1600;
GL1400 + F293 - F766 - GL1600 = 0;
! LA at midnight;
GL1600 + F259 - GL2400 = 0;
! Cover our flight's constraints;
F221 = 1;
F223 = 1;
F274 = 1;
F105 = 1;
F228 = 1;
F230 = 1;
F259 = 1;
F293 = 1;
F412 = 1;
F766 = 1;
F238 = 1;

```

This model assumes no deadheading is used. That is, no plane is flown empty from one city to another in order to position it for the next day. The reader probably figured out by simple intuitive arguments that six aircraft are needed. The following solution gives the details:

```

Optimal solution found at step:          0
Objective value:                        6.000000
Variable      Value      Reduced Cost
GC2400        4.000000      0.0000000
GD2400        1.000000      0.0000000
GL2400        1.000000      0.0000000
F221          1.000000      0.0000000
F223          1.000000      0.0000000
F105          1.000000      0.0000000
F259          1.000000      0.0000000
GC1400        0.0000000      1.0000000
F228          1.000000      0.0000000
F230          1.000000      0.0000000
F412          1.000000      0.0000000
F238          1.000000      0.0000000
GD1100        2.000000      0.0000000
F274          1.000000      0.0000000
F293          1.000000      0.0000000
GD1800        0.0000000      1.0000000
F766          1.000000      0.0000000
GL0800        0.0000000      0.0000000
GL1400        0.0000000      0.0000000
GL1600        0.0000000      1.0000000

```

Thus, there are four aircraft on the ground overnight at Chicago, one overnight at Denver, and one overnight at Los Angeles.

8.9.5 Fleet Assignment

If we have two or more aircraft types, then we have the additional decision of specifying the type of aircraft assigned to each flight. The typical setting is we have a limited number of new aircraft that are more efficient than previous aircraft. Let us extend our previous example by assuming we have two aircraft of type B. They are more fuel-efficient than our original type A aircraft. However, the capacity of type B is slightly less than A. We now probably want to maximize the profit contribution. The profit contribution from assigning an aircraft of type i to flight j is:

- + (revenue from satisfying all demand on flight j)
- (“spill” cost of not being able to serve all demand on j because of the limited capacity of aircraft type i)
- (the operating cost of flying aircraft type i on flight j)
- + (revenue from demand spilled from previous flights captured on this flight).

The spill costs and recoveries are probably the most difficult to estimate.

The previous model easily generalizes with the two modifications:

- a) Conservation of flow constraints is needed for each aircraft type.
- b) The flight coverage constraints become more flexible, because there are now two ways of covering a flight.

After carefully calculating the profit contribution for each combination of aircraft type and flight, we get the following model:

```

! Fleet routing and assignment with two plane types;
! Maximize profit contribution from flights covered;
MAX = 105 * F221A + 121 * F221B + 109 * F223A + 108
      * F223B + 110 * F274A + 115 * F274B + 130 *
      F105A + 140 * F105B + 106 * F228A + 122 *
      F228B + 112 * F230A + 115 * F230B + 132 *
      F259A + 129 * F259B + 115 * F293A + 123 *
      F293B + 133 * F412A + 135 * F412B + 108 *
      F766A + 117 * F766B + 116 * F238A + 124 *
      F238B;
! Conservation of flow constraints;
! for type A aircraft;
! Chicago at 8 am, sources - uses = 0;
F221A - F223A - F105A - F259A - GC1400A + GC2400A=0;
! Chicago at midnight;
F228A + F230A + F412A + F238A + GC1400A - GC2400A=0;
! Denver at 11 am;
  F221A + F223A - F228A - GD1100A + GD2400A = 0;
! Denver at high noon;
F274A - F230A - F293A - F238A + GD1100A - GD1800A=0;
! Denver at midnight;
  F766A - GD2400A + GD1800A = 0;
! LA at 8 am;
  - F274A - GL0800A + GL2400A = 0;
! LA at 1400;
  F105A - F412A + GL0800A - GL1400A = 0;
! LA at 1600;
  F293A - F766A + GL1400A - GL1600A = 0;
! LA at midnight;
  F259A - GL2400A + GL1600A = 0;
! Aircraft type B, conservation of flow;
! Chicago at 8 am;
-F221B - F223B - F105B - F259B - GC1400B +GC2400B=0;
! Chicago at midnight;
F228B + F230B + F412B + F238B + GC1400B - GC2400B=0;
! Denver at 11 am;
  F221B + F223B - F228B - GD1100B + GD2400B = 0;
! Denver at high noon;
F274B - F230B - F293B - F238B + GD1100B - GD1800B=0;
! Denver at midnight;
  F766B - GD2400B + GD1800B = 0;
! LA at 8 am;
  - F274B - GL0800B + GL2400B = 0;
! LA at 1400;
  F105B - F412B + GL0800B - GL1400B = 0;
! LA at 1600;
  F293B - F766B + GL1400B - GL1600B = 0;
! LA at midnight;
  F259B - GL2400B + GL1600B = 0;
! Can put at most one plane on each flight;

```

```

F221A + F221B <= 1;
F223A + F223B <= 1;
F274A + F274B <= 1;
F105A + F105B <= 1;
F228A + F228B <= 1;
F230A + F230B <= 1;
F259A + F259B <= 1;
F293A + F293B <= 1;
F412A + F412B <= 1;
F766A + F766B <= 1;
F238A + F238B <= 1;
! Fleet size of type B;
GC2400B + GD2400B + GL2400B <= 2;

```

The not so obvious solution is:

```

Optimal solution found at step:      37
Objective value:                    1325.000

Variable      Value      Reduced Cost
F221B         1.000000      0.0000000
F223A         1.000000      0.0000000
F274A         1.000000      0.0000000
F105A         1.000000      0.0000000
F228B         1.000000      0.0000000
F230A         1.000000      0.0000000
F259A         1.000000      0.0000000
F293B         1.000000      0.0000000
F412A         1.000000      0.0000000
F766B         1.000000      0.0000000
F238A         1.000000      0.0000000
GC2400A       3.000000      0.0000000
GD1100A       1.000000      0.0000000
GL2400A       1.000000      0.0000000
GC2400B       1.000000      0.0000000
GD1100B       1.000000      0.0000000
GD2400B       1.000000      0.0000000

      Row      Slack or Surplus      Dual Price
      1         1325.000          1.000000
      2         0.0000000          0.000000
      3         0.0000000          0.000000
      4         0.0000000         -25.00000
      5         0.0000000         -25.00000
      6         0.0000000         -25.00000
      7         0.0000000        -133.0000
      8         0.0000000        -133.0000
      9         0.0000000        -133.0000
     10         0.0000000        -133.0000
     11         0.0000000        -17.00000
     12         0.0000000          0.000000
     13         0.0000000         -35.00000
     14         0.0000000         -35.00000
     15         0.0000000         -18.00000
     16         0.0000000        -152.0000

```

17	0.0000000	-135.0000
18	0.0000000	-135.0000
19	0.0000000	-135.0000
20	0.0000000	139.0000
21	0.0000000	134.0000
22	0.0000000	2.0000000
23	0.0000000	263.0000
24	0.0000000	87.00000
25	0.0000000	87.00000
26	0.0000000	265.0000
27	0.0000000	223.0000
28	0.0000000	0.0000000
29	0.0000000	0.0000000
30	0.0000000	91.00000
31	0.0000000	17.00000

Six aircraft are still used. The newer type *B* aircraft cover flights 221, 228, 293, and 766. Since there are two vehicle types, this model is a multicommodity network flow model rather than a pure network flow model. Thus, we are not guaranteed to be able to find a naturally integer optimal solution to the LP. Nevertheless, such was the case for the example above.

Generating an explicit model as above would be tedious. The following is a set-based version of the above model. With the set based version, adding a flight or an aircraft type is a fairly simple clerical operation:

```

MODEL:
SETS: ! Fleet routing and assignment (FLEETRAV);
CITY ;; ! The cities involved;
ACRFT: ! Aircraft types;
FCOST, ! Fixed cost per day of this type;
FSIZE; ! Max fleet size of this type;
FLIGHT;;
FXCXC( FLIGHT, CITY, CITY) :
DEPAT, ! Flight departure time;
ARVAT; ! arrival time at dest.;
AXC( ACRFT, CITY):
OVNITE; ! Number staying overnite by type,city;
AXF( ACRFT, FXCXC):
X, ! Number aircraft used by type,flight;
PC; ! Profit contribution by type,flight;
ENDSETS
DATA:
CITY = ORD DEN LAX;
ACRFT, FCOST, FSIZE =
MD90 0 7
B737 0 2;
FLIGHT = F221 F223 F274 F105 F228 F230 F259 F293 F412 F766 F238;

```

```

FXCXC, DEPAT, ARVAT =
!   Flight  Origin  Dest.  Depart  Arrive;
      F221  ORD    DEN    800    934
      F223  ORD    DEN    900   1039
      F274  LAX    DEN    800   1116
      F105  ORD    LAX   1100   1314
      F228  DEN    ORD   1100   1423
      F230  DEN    ORD   1200   1521
      F259  ORD    LAX   1400   1609
      F293  DEN    LAX   1400   1510
      F412  LAX    ORD   1400   1959
      F766  LAX    DEN   1600   1912
      F238  DEN    ORD   1800   2121;

PC =   ! Profit contribution of each vehicle*flight combo;
      105      109      110      130      106      112
      132      115      133      108      116
      121      108      115      140      122      115
      129      123      135      117      124;

ENDDATA
!-----;
! Maximize profit contribution from flights minus
  overhead cost of aircraft in fleet;
MAX = @SUM( AXF( I, N, J, K): PC( I, N, J, K) * X( I, N, J, K))
      - @SUM( AXC( I, J): FCOST( I) * OVNITE( I, J));
! At any instant, departures in particular, the number of
  cumulative arrivals must be >= number of cumulative departures;
! For each flight of each aircraft type;
@FOR( ACREFT( I):
  @FOR( FXCXC( N, J, K):
! Aircraft on ground in morning +
  number aircraft arrived thus far >=
  number aircraft departed thus far;
  OVNITE( I, J) +
  @SUM( FXCXC( N1, J1, K1) | K1 #EQ# J #AND#
      ARVAT( N1, J1, K1) #LT# DEPAT( N, J, K):
      X( I, N1, J1, J)) >=
  @SUM( FXCXC( N1, J1, K1) | J1 #EQ# J #AND#
      DEPAT( N1, J1, K1) #LE# DEPAT( N, J, K):
      X( I, N1, J, K1));
  ););
! This model does not allow deadheading, so at the end of the day,
  arrivals must equal departures;
@FOR( ACREFT( I):
  @FOR( CITY( J):
    @SUM( AXF( I, N, J1, J): X( I, N, J1, J)) =
    @SUM( AXF( I, N, J, K): X( I, N, J, K));
  );
);
! Each flight must be covered;
@FOR( FXCXC( N, J, K):
  @SUM( AXF( I, N, J, K): X( I, N, J, K)) = 1;
);

```

```

! Fleet size limits;
  @FOR( ACRFT( I):
    @SUM( AXC( I, J): OVNITE( I, J) <= FSIZE( I);
  );
! Fractional planes are not allowed;
  @FOR( AXF: @GIN( X); );
END

```

Sometimes, especially in trucking, one has the option of using rented vehicles to cover only selected trips. With regard to the model, the major modification is that rented vehicles do not have to honor the conservation of flow constraints. Other details that are sometimes included relate to maintenance. With aircraft, for example, a specific aircraft must be taken out of service for maintenance after a specified number of landings, or after a specified number of flying hours, or after a certain elapsed time, whichever occurs first. It is not too difficult to incorporate such details, although the model becomes substantially larger.

8.9.6 Leontief Flow Models

In a Leontief flow model, each activity produces one output. However, it may use zero or more inputs. The following example illustrates.

Example: Islandia Input-Output Model

The country of Islandia has four major export industries: steel, automotive, electronics, and plastics. The economic minister of Islandia would like to maximize exports-imports. The unit of exchange in Islandia is the klutz. The prices in klutzes on the world market per unit of steel, automotive, electronics, and plastics are, respectively: 500, 1500, 300, and 1200. Production of one unit of steel requires 0.02 units of automotive production, 0.01 units of plastics, 250 klutzes of raw material purchased on the world market, plus one-half man-year of labor. Production of one automotive unit requires 0.8 units of steel, 0.15 units of electronics, 0.11 units of plastic, one man-year of labor, and 300 klutzes of imported material. Production of one unit of electronic equipment requires 0.01 units of steel, 0.01 units of automotive, 0.05 units of plastic, half a man-year of labor, and 50 klutzes of imported material. Automotive production is limited at 650,000 units. Production of one unit of plastic requires 0.03 units of automotive production, 0.2 units of steel, 0.05 units of electronics, 2 man-years of labor, plus 300 klutzes of imported materials. The upper limit on plastic is 60,000 units. The total manpower available in Islandia is 830,000 men per year. No steel, automotive, electronics, or plastic products may be imported.

How much should be produced and exported of the various products?

Formulation and Solution of the Islandia Problem

The formulation of an input-output model should follow the same two-step procedure for formulating any LP model. Namely, (1) identify the decision variables and (2) identify the constraints. The key to identifying the decision variables for this problem is to make the distinction between the amount of commodity produced and the amount exported. Once this is done, the decision variables can be represented as:

PROD(STEEL) = units of steel produced,
 PROD(AUTO) = units of automotive produced,
 PROD(PLASTIC) = units of plastic produced,
 PROD(ELECT) = units of electronics produced,
 EXP(STEEL) = units of steel exported,
 EXP(AUTO) = units of automotive exported,
 EXP(PLASTIC) = units of plastic exported,
 EXP(ELECT) = units of electronics exported.

The commodities can be straightforwardly identified as steel, automotive, electronics, plastics, manpower, automotive capacity, and plastics capacity. Thus, there will be seven constraints.

The sets formulation and solution are:

```

MODEL: ! Islandia Input/output model;
SETS:
  COMMO:
    PROD, EXP, REV, COST, MANLAB, CAP;
  CXC(COMMO, COMMO): USERATE;
ENDSETS
DATA:
  COMMO = STEEL, AUTO, PLASTIC, ELECT;
  COST = 250 300 300 50;
  REV = 500 1500 1200 300;
  MANLAB = .5 1 2 .5;
! Amount used of the column commodity per unit
  of the row commodity;
  USERATE= -1 .02 .01 0
            .8 -1 .11 .15
            .2 .03 -1 .05
            .01 .01 .05 -1;
  MANPOWER = 830000;
  CAP = 999999 650000 60000 999999;
ENDDATA
[PROFIT] MAX = @SUM( COMMO: REV * EXP - PROD * COST);
@FOR( COMMO( I):
  [ NETUSE] ! Net use must equal = 0;
  EXP(I) + @SUM(COMMO(J): USERATE(J,I) * PROD(J))
  = 0;
  [CAPLIM] PROD( I) <= CAP( I);
);
[MANLIM] @SUM(COMMO:PROD * MANLAB) < MANPOWER;
END
  
```

Notice this model has the Leontief flow feature. Namely, each decision variable has at most one negative constraint coefficient.

The solution is:

Variable	Value	Reduced Cost
PROD(STEEL)	393958.3	0.0000000
PROD(AUTO)	475833.3	0.0000000
PROD(PLASTIC)	60000.0	0.0000000
PROD(ELECT)	74375.0	0.0000000
EXP(STEEL)	547.9167	0.0000000
EXP(AUTO)	465410.4	0.0000000
EXP(PLASTIC)	0.0	2096.875
EXP(ELECT)	0.0	121.8750
Row	Slack or Surplus	Dual Price
PROFIT	0.4354312E+09	1.0000000
NETUSE(STEEL)	0.0000000	500.0000
CAPLIM(STEEL)	606040.7	0.0000000
NETUSE(AUTO)	0.0000000	1500.000
CAPLIM(AUTO)	174166.7	0.0000000
NETUSE(PLASTIC)	0.0000000	3296.875
CAPLIM(PLASTIC)	0.0000000	2082.656
NETUSE(ELECT)	0.0000000	421.8750
CAPLIM(ELECT)	925624.0	0.0000000
MANLIM	0.0000000	374.0625

The solution indicates the best way of selling Islandia's steel, automotive, electronics, plastics, and manpower resources is in the form of automobiles.

This problem would fit the classical input-output model format of Leontief if, instead of maximizing profits, target levels were set for the export (or consumption) of steel, automotive, and plastics. The problem would then be to determine the production levels necessary to support the specified export/consumption levels. In this case, the objective function is irrelevant.

A natural generalization is to allow alternative technologies for producing various commodities. These various technologies may correspond to the degree of mechanization or the form of energy consumed (e.g., gas, coal, or hydroelectric).

8.9.7 Activity/Resource Diagrams

The graphical approach for depicting a model can be extended to arbitrary LP models. The price one must pay to represent a general LP graphically is one must introduce an additional component type into the network. There are two component types in such a diagram: (1) activities, which correspond to variables and are denoted by a square, and (2) resources, which correspond to constraints and are denoted by a circle. Each constraint can be thought of as corresponding to some commodity and, in words, as saying "uses of commodity \leq sources of commodity". The arrows incident to a square correspond to the resources, commodities, or constraints with which that variable has an interaction. The arrows incident to a circle must obviously then correspond to the activities or decision variables with which the constraint has an interaction.

Example: The Vertically Integrated Farmer

A farmer has 120 acres that can be used for growing wheat or corn. The yield is 55 bushels of wheat or 95 bushels of corn per acre per year. Any fraction of the 120 acres can be devoted to growing wheat or corn. Labor requirements are 4 hours per acre per year, plus 0.15 hours per bushel of wheat, and 0.70

hours per bushel of corn. Cost of seed, fertilizer, etc., is 20 cents per bushel of wheat produced and 12 cents per bushel of corn produced. Wheat can be sold for \$1.75 per bushel and corn for \$0.95 per bushel. Wheat can be bought for \$2.50 per bushel and corn for \$1.50 per bushel.

In addition, the farmer may raise pigs and/or poultry. The farmer sells the pigs or poultry when they reach the age of one year. A pig sells for \$40. He measures the poultry in terms of coops. One coop brings in \$40 at the time of sale. One pig requires 25 bushels of wheat or 20 bushels of corn, plus 25 hours of labor and 25 square feet of floor space. One coop of poultry requires 25 bushels of corn or 10 bushels of wheat, plus 40 hours of labor and 15 square feet of floor space.

The farmer has 10,000 square feet of floor space. He has available per year 2,000 hours of his own time and another 2,000 hours from his family. He can hire labor at \$1.50 per hour. However, for each hour of hired labor, 0.15 hour of the farmer's time is required for supervision. How much land should be devoted to corn and to wheat, and how many pigs and/or poultry should be raised to maximize the farmer's profits? This problem is based on an example in Hadley (1962).

You may find it convenient to use the following variables for this problem:

- WH Wheat harvested (in bushels)
- CH Corn harvested (in bushels)
- PH Pigs raised and sold
- HS Hens raised and sold (number of coops)
- LB Labor hired (in hours)
- WS Wheat marketed or sold (in bushels)
- CS Corn marketed or sold (in bushels)
- CH Corn used to feed hens (in bushels)
- WH Wheat used to feed hens (in bushels)
- CP Corn used to feed pigs (in bushels)
- WP Wheat used to feed pigs (in bushels)
- CB Corn bought (in bushels)
- WB Wheat bought (in bushels)

The activity-resource diagram for the preceding problem is shown in Figure 8.9:

Figure 8.9 An Activity-Resource Diagram

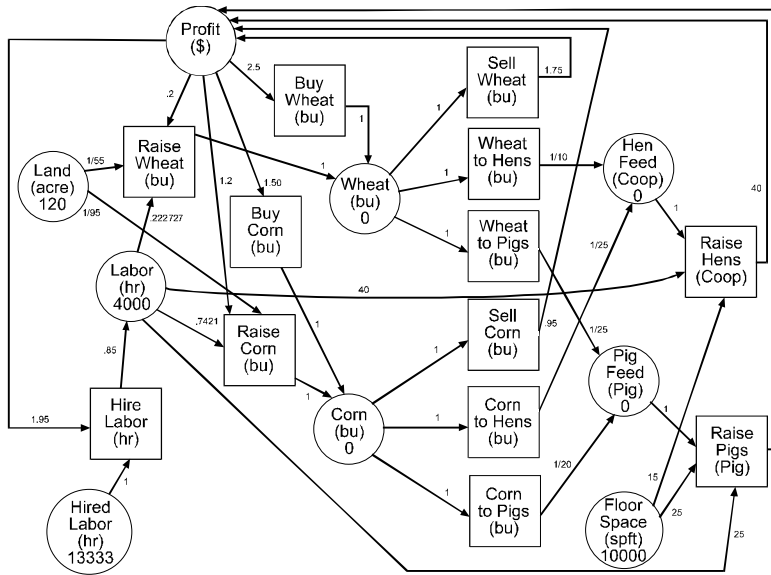

Some things to note about an activity-resource diagram are:

- Each rectangle in the diagram corresponds to a decision variable in the formulation.
- Each circle in the diagram corresponds to a constraint or the objective.
- Each arrow in the diagram corresponds to a coefficient in the formulation.
- Associated with each circle or rectangle is a unit of measure (e.g., hours or bushels).
- The units or dimension of each arrow is:
“Units of the circle” per “unit of the rectangle.”

8.9.8 Spanning Trees

Another simple yet important network-related problem is the spanning tree problem. It arises, for example, in the installation of utilities such as cable, power lines, roads, and sewers to provide services to homes in newly developed regions. Given a set of homes to be connected, we want to find a minimum cost network, so every home is connected to the network. A reasonable approximation to the cost of the network is the sum of the costs of the arcs in the network. If the arcs have positive costs, then a little reflection should convince you the minimum cost network contains no loops (i.e., for any two nodes (or homes) on the network, there is exactly one path connecting them). Such a network is called a spanning tree.

A simple algorithm is available for finding a minimal cost spanning tree, see Kruskal (1956):

1. Set $Y = \{2, 3, 4 \dots n\}$ (i.e., the set of nodes *yet* to be connected).
 $A = \{1\}$ (i.e., the set of *already* connected nodes). We may arbitrarily define node 1 as the root of the tree.
2. If Y is empty, then we are done,
3. else find the shortest arc (i, j) such that i is in A and j is in Y .
4. Add arc (i, j) to the network and
 $A = A + j$,
 $Y = Y - j$.
5. Go to (2).

Because of the above simple and efficient algorithm, LP is not needed to solve the minimum spanning tree problem. In fact, formulating the minimum spanning tree problem as an LP is a bit tedious.

The following illustrates a LINGO model for a spanning tree. This model does not explicitly solve it as above, but just solves it as a straightforward integer program:

```

MODEL:      ! (MNSPTREE);
!Given a set of nodes and the distance between each pair, find
the shortest total distance of links on the network to connect
all the nodes. This is the classic minimal spanning tree (MST)
problem;
SETS:
  CITY: LVL;
      ! LVL( I) = level of city I in tree. LVL( 1) = 0;
  LINK( CITY, CITY):
      DIST, ! The distance matrix;
      X;    ! X( I,J) = 1 if we use link I, J;
ENDSETS
! This model finds the minimum cost network connecting Atlanta,
Chicago, Cincinnati, Houston, LA, and Montreal so that
messages can be sent from Atlanta (base) to all other cities;
DATA:
  CITY= ATL CHI CIN HOU LAX MON;
  ! Distance matrix need not be symmetric. City 1 is base;
  DIST = 0 702 454 842 2396 1196 !from Atlanta;
        702 0 324 1093 2136 764 !from Chicago;
        454 324 0 1137 2180 798 !from Cinci;
        842 1093 1137 0 1616 1857 !from Houston;
        2396 2136 2180 1616 0 2900 !from LA;
        1196 764 798 1857 2900 0;!from Montreal;
ENDDATA
!-----;
!The model size: Warning, may be slow for N > 8;
N = @SIZE( CITY);
!The objective is to minimize total dist. of links;
MIN = @SUM( LINK: DIST * X);
!For city K, except the base, ... ;
@FOR( CITY( K) | K #GT# 1: ! It must be entered;
      @SUM( CITY( I) | I #NE# K: X( I, K) ) = 1;

```

```

!If there is a link from J-K, then LVL(K)=LVL(J)+1.
Note:These are not very powerful for large problems;
@FOR( CITY( J)| J #NE# K:
    LVL( K) >= LVL( J) + X( J, K)
    - ( N - 2) * ( 1 - X( J, K))
    + ( N - 3) * X( K, J); ); );
LVL( 1) = 0; ! City 1 has level 0;
!There must be an arc out of city 1;
@SUM( CITY( J)| J #GT# 1: X( 1, J)) >= 1;
!Make the X's 0/1;
@FOR( LINK: @BIN( X); );
!The level of a city except the base is at least 1 but no more than
N-1, and is 1 if link to the base;
@FOR( CITY( K)| K #GT# 1:
    @BND( 1, LVL( K), 999999);
    LVL( K) <= N - 1 - ( N - 2) * X( 1, K); );
END

```

The solution is:

```

Optimal solution found at step:          16
Objective value:                        4000.000

```

Variable	Value	Reduced Cost
N	6.000000	0.0000000
LVL(CHI)	2.000000	0.0000000
LVL(CIN)	1.000000	0.0000000
LVL(HOU)	1.000000	0.0000000
LVL(LAX)	2.000000	0.0000000
LVL(MON)	3.000000	0.0000000
X(ATL, CIN)	1.000000	454.0000
X(ATL, HOU)	1.000000	842.0000
X(CHI, MON)	1.000000	764.0000
X(CIN, CHI)	1.000000	324.0000
X(HOU, LAX)	1.000000	1616.000

The solution indicates Atlanta should connect to Cincinnati and Houston. Houston, in turn connects to LA. Cincinnati connects to Chicago, and Chicago connects too Montreal.

8.9.9 Steiner Trees

A Steiner tree is a generalization of a minimal spanning tree. The difference is, for a given network, only a specified subset of the nodes need be connected in a Steiner tree. Providing network services in a new housing development is a simple example, such as communication cable, sewer lines, water lines, and roads. Each house must be connected to the network, but not all possible nodes or junctions in the candidate network need be included.

Example

The first computer, an IBM RS6000, to beat a grandmaster, Gary Kasparov, at the game of chess, contained electronic chips designed with the help of Steiner-tree-like optimization methods. A typical VLSI (Very Large Scale Integrated) chip on this computer was less than 2 millimeters on a side. Nevertheless, it might contain over 120 meters of connecting pathways for connecting the various devices on the chip. An important part of increasing the speed of a chip is reducing the length of the paths on the chip. Figure 8.10 shows a chip on which five devices must be connected on a common

tree. Because of previous placement of various devices, the only available links are the ones indicated in the figure. The square nodes, *A*, *B*, *C*, *D*, and *E*, must be connected. The round nodes, *F*, *G*, etc., may be used, but need not be connected. What set of links should be used to minimize the total distance of links?

Figure 8.10 Steiner Tree Problem

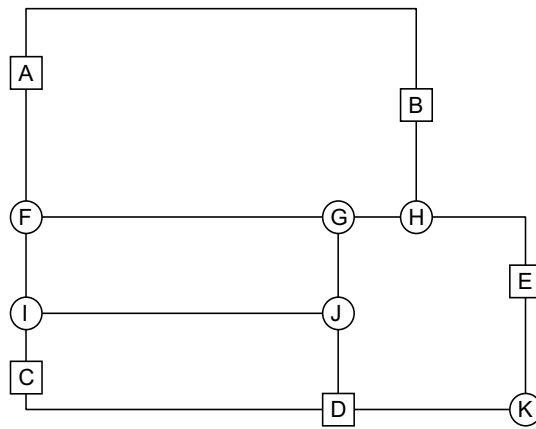

Finding a minimal length Steiner tree is considerably harder than finding a minimal length spanning tree. For small problems, the following LINGO model will find minimal length Steiner trees. The data correspond to the network in Figure 8.10:

```

MODEL:      ! (STEINERT);
!Given a set of nodes, the distance between them, and a specified
subset of the nodes, find the set of links so that the total distance
is minimized, and there is a (unique) path between every pair of
nodes in the specified subset. This is called a Steiner tree problem;
SETS:
  ALLNODE : U;
    ! U( I) = level of node I in the tree;
    ! U( 1) = 0;
  MUSTNOD( ALLNODE); ! The subset of nodes that must be connected;
  LINK( ALLNODE, ALLNODE):
    DIST, ! The distance matrix;
    X;    ! X( I, J) = 1 if we use link I, J;
ENDSETS

```

```

DATA:
  ALLNODE= ! Distance matrix need not be symmetric;
           A  B  C  D  E  F  G  H  I  J  K;
  DIST =0  14 999 999 999 4 999 999 999 999 999
           14 0 999 999 999 999 999 3 999 999 999
           999 999 0 9 999 999 999 999 2 999 999
           999 999 9 0 999 999 999 999 999 3 6
           999 999 999 999 0 999 999 5 999 999 3
           4 999 999 999 999 0 999 999 3 999 999
           999 999 999 999 999 999 0 2 999 3 999
           999 3 999 999 5 999 2 0 999 999 999
           999 999 2 999 999 3 999 999 0 8 999
           999 999 999 3 999 999 3 999 8 0 999
           999 999 999 6 3 999 999 999 999 999 0;
  ! The subset of nodes that must be connected.
  ! The first node must be a must-do node;
  MUSTNOD = A B C D E;
  ENDDATA
  !-----;
  ! The model size: Warning, may be slow for N > 8;
  N = @SIZE( ALLNODE);
  ! Objective is minimize total distance of links;
  MIN = @SUM( LINK: DIST * X);
  ! For each must-do node K, except the base, ... ;
  @FOR( MUSTNOD( K) | K #GT# 1:
  ! It must be entered;
    @SUM( ALLNODE( I) | I #NE# K: X( I, K) ) = 1;
  ! Force U(J)=number arcs between node J and node 1. Note: This is not
  very strong for large problems;
  @FOR( ALLNODE( J) | J #GT# 1 #AND# J #NE# K:
    U( J) >= U( K) + X( K, J) -
      ( N - 2) * ( 1 - X( K, J) ) +
      ( N - 3) * X( J, K); );
  );
  ! There must be an arc out of node 1;
  @SUM( ALLNODE( J) | J #GT# 1: X( 1, J) ) >= 1;
  !If an arc out of node J, there must be an arc in;
  @FOR( ALLNODE( J) | J #GT# 1:
    @FOR( ALLNODE( K) | K #NE# J:
      @SUM( ALLNODE( I) | I #NE# K #AND# I #NE# J:
        X( I, J) >= X( J, K);
      ); );
  ! Make the X's 0/1;
  @FOR( LINK: @BIN( X); );
  ! Level of a node except the base is at least 1, no more than N-1,
  and is 1 if link to the base;
  @FOR( ALLNODE( K) | K #GT# 1:
    @BND( 1, U( K), 999999);
    U( K) < N - 1 - ( N - 2) * X( 1, K); );
  END

```

The solution has a cost of 33. The list of links used is:

```

Optimal solution found at step:      30
Objective value:                    33.00000
Branch count:                        0
Variable      Value      Reduced Cost
X( A, F)     1.000000    4.000000
X( F, I)     1.000000    3.000000
X( G, H)     1.000000    2.000000
X( H, B)     1.000000    3.000000
X( H, E)     1.000000    5.000000
X( I, C)     1.000000    2.000000
X( I, J)     1.000000    8.000000
X( J, D)     1.000000    3.000000
X( J, G)     1.000000    3.000000
    
```

The corresponding minimal length Steiner tree appears in Figure 8.11:

Figure 8.11 Minimal Length Steiner Tree

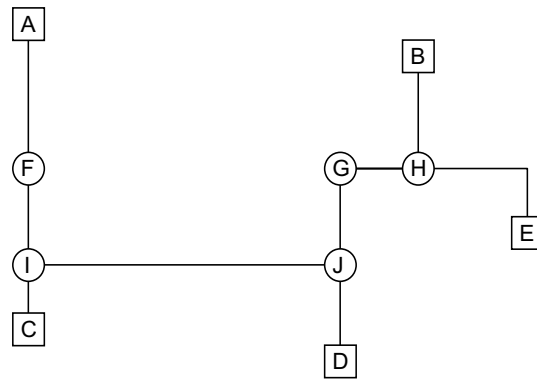

Notice node *K* is not in the tree. This example is missing two important features of real chip design:

- a) It shows only two-dimensional paths. In fact, three-dimensional paths are possible (and typically needed) by adding vertical layers to the chip.
- b) It only shows one tree; whereas, in fact, there may be many distinct trees to be constructed (e.g., some devices need to be connected to electrical “ground”, others need to be connected to the clock signal, etc.).

8.10 Nonlinear Networks

There are a number of important problems where the constraints describe a network problem. However, either the objective is nonlinear, or there are additional conditions on the network that are nonlinear. The first example describes a transportation problem where the value of shipping or assigning an item to a destination depends upon (a) how many items have already been shipped to that destination, and (b) the type of item and type of destination. In the military, this kind of problem is known as a weapons assignment problem. If we define:

$$x(i,j) = \text{number of units of type } j \text{ assigned to task } i;$$

$$p(i,j) = \text{Prob}\{\text{a unit of type } j \text{ will not successfully complete task } i\}.$$

Then, assuming independence, the probability task i is successfully completed is:

$$1 - \prod_j p(i,j)^{x(i,j)}$$

A reasonable objective is to maximize the value of successfully completed tasks. The following model illustrates this idea, using data from Bracken and McCormick (1968):

```

MODEL:
! (TARGET) Bracken and McCormick;
SETS:
DESTN/1..20/: VALUE, DEM, LFAILP;
SOURCE/1..5/: AVAIL;
DXS( DESTN, SOURCE): PROB, VOL;
ENDSETS
DATA:
! Probability that a unit from source J will NOT do the job at
destination I;
PROB=
1.00      .84      .96      1.00      .92
.95      .83      .95      1.00      .94
1.00      .85      .96      1.00      .92
1.00      .84      .96      1.00      .95
1.00      .85      .96      1.00      .95
.85      .81      .90      1.00      .98
.90      .81      .92      1.00      .98
.85      .82      .91      1.00      1.00
.80      .80      .92      1.00      1.00
1.00      .86      .95      .96      .90
1.00      1.00      .99      .91      .95
1.00      .98      .98      .92      .96
1.00      1.00      .99      .91      .91
1.00      .88      .98      .92      .98
1.00      .87      .97      .98      .99
1.00      .88      .98      .93      .99
1.00      .85      .95      1.00      1.00
.95      .84      .92      1.00      1.00
1.00      .85      .93      1.00      1.00
1.00      .85      .92      1.00      1.00;
! Units available at each source;
AVAIL= 200      100      300      150      250;
! Min units required at each destination;

```



```

DEM=
 30  0  0  0  0 100  0  0  0  40
  0  0  0  50 70  35  0  0  0  10;
! Value of satisfying destination J;
VALUE=
 60  50  50  75  40  60  35  30  25 150
 30  45 125 200 200 130 100 100 100 150;
ENDDATA
!Max sum over I:(value of destn I)
  *Prob{success at I};
  MAX = @SUM( DESTN( I): VALUE( I) *
    ( 1 - @EXP( LFAILP( I))));
! The supply constraints;@FOR( SOURCE( J):
  @SUM( DESTN( I): VOL( I, J)) <= AVAIL( J));
@FOR( DESTN( I):
!The demand constraints;
@SUM( SOURCE( J): VOL( I, J)) > DEM( I);
!Compute log of destination I failure probability;
@FREE( LFAILP( I));
  LFAILP( I) =
  @SUM(SOURCE( J): @LOG( PROB( I, J)) * VOL( I, J)););
END

```

Observe the model could be “simplified” slightly by using the equation computing $LFAILP(I)$ to substitute out $LFAILP(I)$ in the objective. The time required to solve the model would probably increase substantially, however, if this substitution were made. The reason is the number of variables appearing nonlinearly in the objective increases dramatically. A general rule for nonlinear programs is:

If you can reduce the number of variables that appear nonlinearly in the objective or a constraint by using *linear* constraints to define intermediate variables, then it is probably worth doing.

Verify the constraint defining $LFAILP(I)$ is linear in both $LFAILP(I)$ and $VOL(I, J)$.

Notice the solution involves fractional assignments. A simple generalization of the model is to require the $VOL(I, J)$ variables to be general integers:

Optimal solution found at step:	152	
Objective value:	1735.570	
Variable	Value	Reduced Cost
VOL(1, 5)	50.81594	0.0000000
VOL(2, 1)	13.51739	0.0000000
VOL(2, 2)	1.360311	0.2176940
VOL(2, 5)	45.40872	0.0000000
VOL(3, 5)	48.62891	0.0000000
VOL(4, 2)	23.48955	0.0000000
VOL(5, 2)	20.89957	0.0000000
VOL(6, 1)	100.0000	0.0000000
VOL(7, 1)	39.10010	0.0000000
VOL(8, 1)	27.06643	0.0000000
VOL(8, 5)	0.4547474E-12	0.0000000
VOL(9, 1)	20.31608	0.0000000
VOL(10, 5)	51.13144	0.0000000
VOL(11, 4)	33.19754	0.0000000

VOL(12, 4)	40.93452	0.0000000
VOL(13, 5)	54.01499	0.0000000
VOL(14, 4)	58.82350	0.0000000
VOL(14, 5)	0.5684342E-13	0.0000000
VOL(15, 2)	26.21095	0.0000000
VOL(15, 3)	43.78905	0.0000000
VOL(16, 2)	24.23657	0.2176940
VOL(16, 4)	17.04444	0.0000000
VOL(17, 2)	3.803054	0.0000000
VOL(17, 3)	72.03255	-0.4182476E-05
VOL(18, 2)	0.8881784E-15	0.1489908
VOL(18, 3)	57.55117	0.0000000
VOL(19, 3)	64.21183	0.0000000
VOL(20, 3)	62.41540	0.0000000

8.11 Problems

- The Slick Oil Company is preparing to make next month's pipeline shipment decisions. The Los Angeles terminal will require 200,000 barrels of oil. This oil can be supplied from either Houston or Casper, Wyoming. Houston can supply oil to L.A. at a transportation cost of \$.25 per barrel. Casper can supply L.A. at a transportation cost of \$.28 per barrel. The St. Louis terminal will require 120,000 barrels. St. Louis can be supplied from Houston at a cost of \$.18 per barrel and from Casper at a cost of \$.22 per barrel. The terminal at Freshair, Indiana requires 230,000 barrels. Oil can be shipped to Freshair from Casper at a cost of \$.21 per barrel, from Houston at a cost of \$.19 per barrel, and from Titusville, Pa. at a cost of \$.17 per barrel. Casper will have a total of 250,000 barrels available to be shipped. Houston will have 350,000 barrels available to be shipped. Because of limited pipeline capacity, no more than 180,000 barrels can be shipped from Casper to L.A. next month and no more than 150,000 barrels from Houston to L.A. The Newark, N.J. terminal will require 190,000 barrels next month. It can be supplied only from Titusville at a cost of \$.14 per barrel. The Atlanta terminal will require 150,000 barrels next month. Atlanta can be supplied from Titusville at a cost of \$.16 per barrel or from Houston at a cost of \$.20 per barrel. Titusville will have a total of 300,000 barrels available to be shipped.

Formulate the problem of finding the minimum transportation cost distribution plan as a linear program.

- Louis Szathjoseph, proprietor of the Boulangerie Restaurant, knows he will need 40, 70, and 60 tablecloths on Thursday, Friday, and Saturday, respectively, for scheduled banquets. He can rent tablecloths for three days for \$2 each. A tablecloth must be laundered before it can be reused. He can have them cleaned overnight for \$1.50 each. He can have them laundered by regular one-day service (e.g., one used on Thursday could be reused on Saturday) for \$.80 each. There are currently 20 clean tablecloths on hand with none dirty or at the laundry. Rented tablecloths need not be cleaned before returning.
 - What are the decision variables?
 - Formulate the LP appropriate for minimizing the total cost of renting and laundering the tablecloths. For each day, you will probably have a constraint requiring the number of clean tablecloths available to at least equal that day's demand. For each of the first two days, you will probably want a constraint requiring the number of tablecloths sent to the laundry not to exceed those that have been made dirty. Is it a network LP?

3. The Millersburg Supply Company uses a large fleet of vehicles it leases from manufacturers. The following pattern of vehicle requirements is forecast for the next 8 months:

Month	Jan	Feb	Mar	Apr	May	Jun	Jul	Aug
Vehicles Required	430	410	440	390	425	450	465	470

Vehicles can be leased from various manufacturers at various costs and for various lengths of time. The best plans available are: three-month lease, \$1,700; four-month lease, \$2,000; five-month lease, \$2,600. A lease can be started in any month. On January 1, there are 200 cars on lease, all of which go off lease at the end of February.

- a) Formulate an approach for minimizing Millersburg’s leasing costs over the 8 months.
 - b) Show that this problem is a network problem.
4. Several years ago, a university in the Westwood section of Los Angeles introduced a bidding system for assigning professors to teach courses in its business school. The table below describes a small, slightly simplified three-professor/two-course version. For the upcoming year, each professor submits a bid for each course and places limits on how many courses he or she wants to teach in each of the school’s two semesters. Each professor, however, is expected to teach four courses total per year (at most three per semester).

	Prof. X	Prof. Y	Prof. Z	Sections Needed in the Year	
				Min	Max
Fall Courses	≤ 1	≤ 3	≤ 1		
Spring Courses	≤ 3	≤ 2	≤ 3		
Course A bids	6	3	8	3	7
Course B bids	4	7	2	2	8

From the table, note that: professor *Z* strongly prefers to teach course *A*; whereas, professor *X* has a slight preference for *A*. Professor *Y* does not want to teach more than two course sections in the Spring. Over both semesters, at least three sections of Course *A* must be taught. Can you formulate this problem as a network problem?

5. *Aircraft Fuel Ferrying Problem.* Fuel cost is one of the major components of variable operating cost for an airline. Some cities collect a tax on aircraft fuel sold at their airports. Thus, the cost per liter of fuel may vary noticeably from one airport to another. A standard problem with any airliner is the determination of how much fuel to take on at each stop. Fuel consumption is minimized if just sufficient fuel is taken on at each stop to fly the plane to the next stop. This policy, however, disregards the fact that fuel prices may differ from one airport to the next. Buying all the fuel at the cheapest stop may not be the cheapest policy either. This might require carrying large fuel loads that would in turn cause large amounts of fuel to be burned in ferrying the fuel. The refueling considerations at a given stop on a route are summarized by the following three numbers: (a) the minimum amount of fuel that must be on board at takeoff to make it to the next stop, (b) the cost per liter of fuel purchased at this stop, and (c) the amount of additional fuel above the minimum that is burned per liter of fuel delivered to the next stop. These figures are

given below for an airplane that starts at Dallas, goes to Atlanta, then Chicago, Des Moines, St. Louis, and back to Dallas.

	Dallas	Atlanta	Chicago	Des Moines	St. Louis
a)	3100	2700	1330	1350	2500
b)	.29	.34	.35	.31	.33
c)	.04	.03	.02	.01	.04

For example to fly from Dallas to Atlanta, the plane must take off with at least 3100 liters of fuel. Any fuel purchased in Dallas costs \$0.29 per liter. For each liter of fuel delivered to Atlanta (i.e., still in the tank), an additional .04 liters had to be put in at Dallas. Alternatively, each additional 1.04 liters loaded at Dallas, results in an additional liter delivered to Atlanta. The plane has a maximum fuel carrying capacity of 6000 liters, which we will assume is independent of airport. Also, assume the minimum amount of reserve fuel that must be on board for safety reasons is fixed independent of airport, so we can act as if no reserve is required.

Formulate and solve a model for deciding how much fuel to buy at each airport. Is this problem any form of a network LP?

- Show that any LP can be converted to an equivalent LP in which every column (variable) has at most three nonzero constraint coefficients. What does this suggest about the fundamental complexity of a network LP vs. a general LP?
- Figure 8.12 is the activity-on-arc diagram showing the precedence relations among the five activities involved in repairing a refinery. The three numbers above each arc represent (from left to right, respectively) the normal time for performing the activity in days, the time to perform the activity if crashed to the maximum extent, and the additional cost in \$1000s for each day the activity is shortened. An activity can be partially crashed. It is desired the project be completed in 15 days. Write an LP formulation for determining how much each activity should be crashed.

Figure 8.12 PERT Diagram with Crashing Allowed

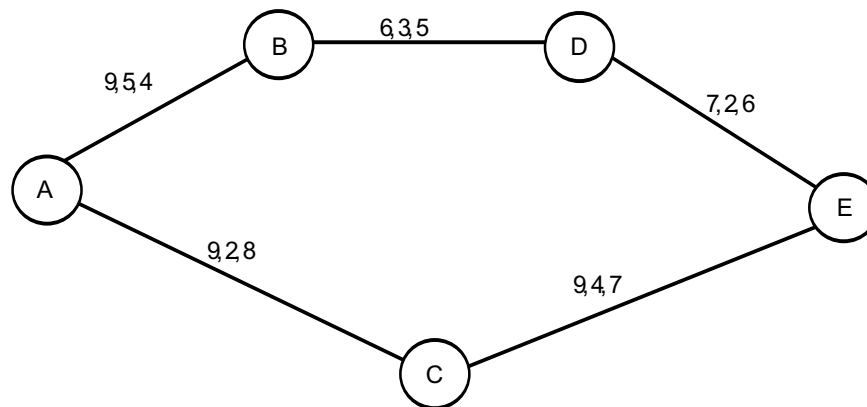

8. Given n currencies, the one-period currency exchange problem is characterized by a beginning inventory vector, an exchange rate matrix, and an ending inventory requirement vector defined as follows:

n_i = amount of cash on hand in currency i , at the beginning of the period measured in units of currency i , for $i = 1, 2, \dots, n$;

r_{ij} = units of currency j obtainable per unit of currency i for $i = 1, 2, \dots, n, j = 1, 2, \dots, n$. Note that $r_{ii} = 1$ and, in general, we can expect $r_{ij} < 1/r_{ji}$, for $i \neq j$.

e_i = minimum ending inventory requirement for currency i , for $i = 1, 2, \dots, n$. That is, at the end of the period, we must have at least e_i units of currency i on hand.

The decision variables are:

X_{ij} = amount of currency i converted into currency j , for $i = 1, 2, \dots, n; j = 1, 2, \dots, n$.

Formulate a model for determining an efficient set of values for the X_{ij} . The formulation should have the following features:

- If there is a “money pump” kind of arbitrage opportunity, the model will find it.
 - It should not be biased against any particular currency (i.e., the solution should be independent of which currency is called 1).
 - If a currency is worthless, you should buy no more of it than sufficient to meet the minimum requirement. A currency i is worthless if $r_{ij} = 0$, for all $j \neq i$.
9. The following linear program happens to be a network LP. Draw the corresponding network. Label the nodes and links.

```

MIN = 4 * T + 2 * U + 3 * V + 5 * W + 6 * X + 7 * Y + 9 * Z;
[A] T + Y + Z >= 4;
[B] U - W - X - Z = 0;
[C] - T + W = 1;
[D] V + X - Y = 2;
[E] U + V <= 7;
END
    
```

10. Consider a set of three flights provided by an airline to serve four cities, A, B, C , and H . The airline uses a two-fare pricing structure. The decision of how many seats or capacity to allocate to each price class is sometimes called yield or revenue management. We would like to decide upon how many seats to allocate to each fare class on each flight. Node H is a hub for changing planes. The three flights are: from A to H , H to B , and H to C . The respective flight capacities are 120, 100, and 110. Customer demand has the following characteristics:

Itinerary	Class 1 Demand	At a Price of	Class 2 Demand	At a Price of
AH	33	190	56	90
AB (via H)	24	244	43	193
AC (via H)	12	261	67	199
HB	44	140	69	80
HC	16	186	17	103

How many seats should be allocated to each class on each of the three flights? An obvious solution, if it is feasible, is to set aside enough class 1 seats on every flight, so all class 1 travelers can be accommodated. Thus, the leg AH would get $33 + 24 + 12 = 69$ class 1 seats, leg HB would get $24 + 44 = 68$ class 1 seats and leg HC would get $12 + 16 = 28$ class 1 seats. The total revenue of this solution is \$38,854. Is this the most profitable solution?

11. A common distribution system structure in many parts of the world is the three-level system composed of plants, distribution centers (DC), and outlets. A cost minimization model for a system composed of two plants (A & B), three DC's (X , Y , and Z), and four outlets (1, 2, 3, and 4) is shown below:

```

MIN = AX + 2 * AY + 3 * BX + BY + 2 * BZ + 5 * X1 +
      7 * X2 + 9 * Y1 + 6 * Y2 + 7 * Y3 + 8 * Z2 + 7
      * Z3 + 4 * Z4;
  AX + AY = 9;
  BX + BY + BZ = 8;
- AX - BX + X1 + X2 = 0;
- AY - BY + Y1 + Y2 + Y3 = 0;
- BZ + Z2 + Z3 + Z4 = 0;
- X1 - Y1 = - 3;
- X2 - Y2 - Z2 = - 5;
- Y3 - Z3 = - 4;
- Z4 = - 5;
END

```

Part of the solution is shown below:

Objective value:		121.0000
Variable	Value	Reduced Cost
AX	3.000000	0.000000
AY	6.000000	0.000000
BX	0.000000	3.000000
BY	3.000000	0.000000
BZ	5.000000	0.000000
X1	3.000000	0.000000
X2	0.000000	0.000000
Y1	0.000000	5.000000
Y2	5.000000	0.000000
Y3	4.000000	0.000000
Z2	0.000000	3.000000
Z3	0.000000	1.000000
Z4	5.000000	0.000000

- Is there an alternate optimal solution to this distribution problem?
- A trucking firm that offers services from city Y to city 1 would like to get more of your business. At what price per unit might you be willing to give them more business according to the above solution?
- The demand at city 2 has been decreased to 3 units. Show how the model is changed.
- The capacity of plant B has been increased to 13 units. Show how the model is changed.

- e) Distribution center *Y* is actually in a large city where there is an untapped demand of 3 units that could be served directly from the DC at *Y*. Show how to include this additional demand at *Y*.
12. Labor on the first shift of a day (8 a.m. to 4 p.m.) costs \$15 per person × hour. Labor on the second (4 p.m. to midnight) and third (midnight to 8 a.m.) shifts cost \$20 per person × hour and \$25 per person × hour, respectively. A certain task requires 18 days if done with just first shift labor and costs \$8640. Second and third shift labor has the same efficiency as first shift labor. The only way of accelerating or crashing the task is to add additional shifts for one or more additional days. The total cost of the task consists solely of labor costs.

Complete the following crash cost table for this task.

Task time in whole days	18	17	16	15	14	13	12	11	10	9	8	7	6	5	4
Total cost	8640														

13. You are on a camping trip and wish to prepare a recipe for a certain food delight that calls for 4 cups of water. The only containers in your possession are two ungraduated steel vessels, one of 3-cup capacity, the other of 5-cup capacity. Show how you can solve this problem by drawing a certain two-dimensional network, where each node represents a specific combination of contents in your two containers.
14. Following is part of the schedule for an airline:

Flight	City		Time		Difference in Profit	
	Depart	Arrive	Depart	Arrive		
1	221	ORD	DEN	0800	0934	+\$3000
2	223	ORD	DEN	0900	1039	-\$4000
3	274	LAX	DEN	0800	1116	-\$3000
4	105	ORD	LAX	1100	1314	+\$10000
5	228	DEN	ORD	1100	1423	-\$2000
6	230	DEN	ORD	1200	1521	-\$3000
7	259	ORD	LAX	1400	1609	+\$4000
8	293	DEN	LAX	1400	1510	+\$1000
9	412	LAX	ORD	1400	1959	+\$7000
10	766	LAX	DEN	1600	1912	+\$2000
11	238	DEN	ORD	1800	2121	-\$4000

The airline currently flies the above schedule using standard Boeing 737 aircraft. Boeing is trying to convince the airline to use a new aircraft, the 737-XX, known affectionately as the Dos Equis. The 737-XX consumes more fuel per kilometer. However, it is sufficiently larger such that, if it carries enough passengers, it is more efficient per passenger kilometer. The “Difference in Profit” column above shows the relative profitability of using the 737-XX instead of the standard 737 on each flight. The airline is considering using at most one 737-XX.

Based on the available information, analyze the wisdom of using the 737-XX in place of one of the standard 737's.

15. The following linear program happens to be a network LP:

```

MIN = 9 * S + 4 * T + 2 * U + 3 * V + 5 * W + 6 * X + 7 * Y;
[A] - T + W = 1;
[B] S + T + Y >= 4;
[C] U - W - X - S = 0;
[D] U + V <= 7;
[E] V + X - Y = 2;
END

```

- a) Draw the corresponding network.
- b) Label the nodes and links.

16. A small, but growing, long-distance phone company, SBG Inc., is trying to decide in which markets it should try to expand. It has used the following model to decide how to maximize the calls it carries per hour:

```

MAX = P1SEADNV + P2SEADNV + P1SEACHI + P2SEACHI
      + P1SEAATL + P2SEAATL + P1SEAMIA + P2SEAMIA
      + P1DNVCHI + P2DNVCHI + P1DNVATL + P2DNVATL
      + P1DNVMIA + P2DNVMIA + P1CHIATL + P2CHIATL
      + P1CHIMIA + P2CHIMIA + P1ATLMIA;
[LSEADNV] P1SEADNV + P2SEADNV + P1SEACHI + P2SEACHI + P2SEAMIA
          + P1DNVCHI + P2DNVATL + P2DNVMIA + P2CHIATL +
          P2CHIMIA <= 95;
[LSEACHI] P2SEADNV + P1SEACHI + P1SEAATL + P1SEAMIA
          + P1DNVCHI + P2DNVATL + P2DNVMIA + P2CHIATL +
          P2CHIMIA <= 80;
[LDNVATL] P2SEADNV + P2SEACHI + P2SEAATL + P2SEAMIA
          + P2DNVCHI + P1DNVATL + P1DNVMIA + P2CHIATL +
          P2CHIMIA <= 200;
[LCHIATL] P2SEADNV + P2SEACHI + P1SEAATL + P1SEAMIA
          + P2DNVCHI + P2DNVATL + P2DNVMIA + P1CHIATL +
          P1CHIMIA <= 110;
[LATLMIA] P1SEAMIA + P2SEAMIA + P1DNVMIA + P2DNVMIA
          + P1CHIMIA + P2CHIMIA + P1ATLMIA <= 105;
[DSEADNV] P1SEADNV + P2SEADNV <= 10;
[DSEACHI] P1SEACHI + P2SEACHI <= 20;
[DSEAATL] P1SEAATL + P2SEAATL <= 38;
[DSEAMIA] P1SEAMIA + P2SEAMIA <= 33;
[DDNVCHI] P1DNVCHI + P2DNVCHI <= 42;
[DDNVATL] P1DNVATL + P2DNVATL <= 48;
[DDNVMIA] P1DNVMIA + P2DNVMIA <= 23;
[DCHIATL] P1CHIATL + P2CHIATL <= 90;
[DCHIMIA] P1CHIMIA + P2CHIMIA <= 36;
[DATLMIA] P1ATLMIA <= 26;

```

Now, it would like to refine the model, so it takes into account not only revenue per call, but also modest variable costs associated with each link for carrying a call. The variable cost per typical call according to link used is shown in the table below:

		Variable Cost/Call			
		DNV	CHI	ATL	MIA
SEA		.11	.16	X	X
DNV			X	.15	X
CHI				.06	X
ATL					.07

An X means there is no direct link between the two cities. SBG would like to find the combination of calls to accept to maximize profit contribution. Suppose the typical revenue per call between *ATL* and *SEA* is \$1.20. Show how to modify the model just to represent the revenue and cost information for the demand between *SEA* and *ATL*.

17. Below is a four-activity project network presented in activity-on-node form, along with information on crashing opportunities for each activity:

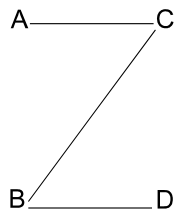

Activity	Normal Time (days)	Crash Cost Per Day	Minimum Possible Time (days)
A	8	3	4
B	7	4	5
C	6	6	3
D	9	2	5

Complete the following tabulation of crashing cost vs. project length:

Step	Project Length	Incremental Crashing Cost/Day	Total Crashing Cost	Activities to Crash
0	16	0	0	—
1				
2				
3				
4				

Multi-period Planning Problems

9.1 Introduction

One of the most important uses of optimization is in multi-period planning. Most of the problems we have considered thus far have been essentially one-period problems. The formulations acted as if decisions this period were decoupled from decisions in future periods. Typically, however, if we produce more of a certain product this period than required by a constraint, that extra production will not be worthless, but can probably be used next period.

These interactions between periods can be represented very easily within optimization models. In fact, most large linear programs encountered in practice are multi-period models. A common synonym for “multi-period” is “dynamic” (e.g., a multi-period LP may be referred to as a dynamic model).

In some applications, the need to represent the multi-period aspects is quite obvious. One setting in which multi-period LP has been used for a number of years is in the manufacture of cheese. Production decisions must be made monthly or even weekly. The production time for many cheeses, however, may be months. For example, Parmesan cheese may need to be stored in inventory for up to ten months. What Americans call Swiss cheese may take from two to four months. The various grades of cheddar obtained depend upon the number of weeks held in storage. Sharp cheddar may be aged up to a year in storage. Clearly, in such applications, the multi-period aspect of the model is the important feature.

Models for planning over time represent the real world by partitioning time into a number of periods. The portion of the model corresponding to a single period might be some combination of product mix, blending, and other models. These single-period or static models are linked by:

1. A link or inventory variable for each commodity and period. The linking variable represents the amount of commodity transferred from one period to the next.
2. A “material balance” or “sources = uses” constraint for each commodity and period. The simplest form of this constraint is “beginning inventory + production = ending inventory + goods sold”.

Multi-period models are usually used in a rolling or sliding format. In this format, the model is solved at the beginning of each period. The recommendations of the solution for the first period are implemented. As one period elapses and better data and forecasts become available, the model is slid

forward one period. The period that had been number 2 becomes number 1, etc., and the whole process is repeated. When using a model in this sliding fashion, a practical problem is that, as the new information becomes available, this period's "optimal" solution may be drastically different from the previous period's "optimal" solution. The people who have to implement the solution may find this disconcerting. The scheduling system is said to suffer from nervousness. An approach that has been used successfully in scheduling ships, scheduling plant closings/openings, and scheduling production of breakfast cereal, see Brown, Dell, and Wood (1997), is to specify a "reference" solution (e.g., the previous period's solution). One then defines a secondary objective of minimizing the deviation of the current solution from the reference solution. If one puts zero weight on the secondary objective, then one gets the theoretically optimal solution. If one puts an extremely high weight on the secondary objective, then one simply gets the reference solution returned. If a modest weight is placed on the secondary objective, then one gets a solution that is a good compromise between low cost as measured by standard accounting, but is also close to the reference solution.

There is nothing sacred about having all periods of the same length. For example, when a petroleum company plans production for the coming year, it is sensible to have the periods correspond to the seasons of the year. One possible partition is to have the winter period extend from December 1 to March 15, the spring period extend from March 16 to May 15, the summer period extend from May 16 to September 15, and the autumn period extend from September 16 to November 30.

Some companies, such as forest product or mineral resource based companies, plan as much as 50 years into the future. In such a case, one might have the first two periods be one year each, the next period be two years, the next two periods three years each, the next two periods five years each, and the final three periods ten years each.

Inter-period interactions are usually accounted for in models by the introduction of inventory decision variables. These variables "link" adjacent periods. As an example, suppose we have a single explicit decision to make each period. Namely, how much to produce of a single product. Call this decision variable for period j , P_j . Further, suppose we have contracts to sell known amounts of this product, d_j , in period j . Define the decision variable I_j as the amount of inventory left over at the end of period j . By this convention, the beginning inventory in period j is I_{j-1} . The LP formulation will then contain one "sources of product = uses of product" constraint for each period. For period 2, the sources of product are beginning inventory, I_1 , and production in the period, P_2 . The uses of product are demand, d_2 , and end of period inventory, I_2 . For example, if $d_2 = 60$ and $d_3 = 40$, then the constraint for period 2 is:

$$I_1 + P_2 = 60 + I_2 \quad \text{or} \quad I_1 + P_2 - I_2 = 60.$$

The constraint for period 3 is:

$$I_2 + P_3 - I_3 = 40.$$

Notice how I_2 "links" (i.e., appears in both the constraints for periods 2 and 3).

In some problems, the net outflow need not exactly equal the net inflow into the next period. For example, if the product is cash, then one of the linking variables may be short-term borrowing or lending. For each dollar carried over from period 2 by lending, we will enter period 3 with \$1.05 if the interest rate is 5% per period.

On the other hand, if the "product" is workforce and there is a predictable attrition rate of 10% per period, then the above two constraints would be modified to:

$$\begin{aligned} .90I_1 + P_2 - I_2 &= 60 \\ .90I_2 + P_3 - I_3 &= 40. \end{aligned}$$

In this case, P_i is the number hired in period i .

The following example provides a simplified illustration of a single-product, multi-period planning situation.

9.2 A Dynamic Production Problem

A company produces one product for which the demand for the next four quarters is predicted to be:

Spring	Summer	Autumn	Winter
20	30	50	60

Assuming all the demand is to be met, there are two extreme policies that might be followed:

1. “Track” demand with production and carry no inventory.
2. Produce at a constant rate of 40 units per quarter and allow inventory to absorb the fluctuations in demand.

There are costs associated with carrying inventory and costs associated with varying the production level, so one would expect the least-cost policy is probably a combination of (1) and (2) (i.e., carry some inventory, but also vary the production level somewhat).

For costing purposes, the company estimates changing the production level from one period to the next costs \$600 per unit. These costs are often called “hiring and firing” costs. It is estimated that charging \$700 for each unit of inventory at the end of the period can accurately approximate inventory costs. The initial inventory is zero and the initial production level is 40 units per quarter. We require these same levels be achieved or returned to at the end of the winter quarter.

We can now calculate the production change costs associated with the no-inventory policy as:

$$\$600 \times (20 + 10 + 20 + 10 + 20) = \$48,000.$$

On the other hand, the inventory costs associated with the constant production policy is:

$$\$700 \times (20 + 30 + 20 + 0) = \$49,000.$$

The least cost policy is probably a mix of these two pure policies. We can find the least-cost policy by formulating a linear program.

9.2.1 Formulation

The following definitions of variables will be useful:

P_i = number of units produced in period i , for $i = 1, 2, 3$, and 4 ;

I_i = units in inventory at the end of period i ;

U_i = increase in production level between period $i - 1$ and i ;

D_i = decrease in production level between $i - 1$ and i .

The P_i variables are the obvious decision variables. It is useful to define the I_i , U_i , and D_i variables, so we can conveniently compute the costs each period.

To minimize the cost per year, we want to minimize the sum of inventory costs:

$$\$700 I_1 + \$700 I_2 + \$700 I_3 + \$700 I_4$$

plus production change costs:

$$\begin{aligned} & \$600 U_1 + \$600 U_2 + \$600 U_3 + \$600 U_4 + \$600 U_5 \\ & + \$600 D_1 + \$600 D_2 + \$600 D_3 + \$600 D_4 + \$600 D_5. \end{aligned}$$

We have added a U_5 and a D_5 in order to charge for the production level change back to 40, if needed at the end of the 4th period.

9.2.2 Constraints

Every multi-period problem will have a “material balance” or “sources = uses” constraint for each product per period. The usual form of these constraints in words is:

$$\textit{beginning inventory} + \textit{production} - \textit{ending inventory} = \textit{demand}.$$

Algebraically, these constraints for the problem at hand are:

$$\begin{aligned} P_1 - I_1 &= 20 \\ I_1 + P_2 - I_2 &= 30 \\ I_2 + P_3 - I_3 &= 50 \\ I_3 + P_4 &= 60 \end{aligned}$$

Notice I_4 and I_0 do not appear in the first and last constraints, because initial and ending inventories are required to be zero.

If the formulation is solved as is, there is nothing to force U_1 , D_1 , etc., to be greater than zero. Therefore, the solution will be the pure production policy. Namely, $P_1 = 20$, $P_2 = 30$, $P_3 = 50$, $P_4 = 60$. This policy implies a production increase at the end of every period, except the last. This suggests a way of forcing U_1 , U_2 , U_3 , and U_4 to take the proper values is to append the constraints:

$$\begin{aligned} U_1 &\geq P_1 - 40 \\ U_2 &\geq P_2 - P_1 \\ U_3 &\geq P_3 - P_2 \\ U_4 &\geq P_4 - P_3. \end{aligned}$$

Production decreases are still not properly measured. An analogous set of four constraints should take care of this problem, specifically:

$$\begin{aligned} D_1 &\geq 40 - P_1 \\ D_2 &\geq P_1 - P_2 \\ D_3 &\geq P_2 - P_3 \\ D_4 &\geq P_3 - P_4. \end{aligned}$$

To incorporate the requirement that the production level be returned to 40 at the end of the winter quarter, we add the variables U_5 and D_5 to measure changes at the end of the last quarter. U_5 and D_5 are forced to take on the right values with the constraints:

$$\begin{aligned} U_5 &\geq 40 - P_4 \\ D_5 &\geq P_4 - 40. \end{aligned}$$

Before moving on, we will note the production-change constraints can be reduced to 5 constraints from the 10 implied by the above form. The key observation is two constraints such as:

$$U_2 \geq P_2 - P_1$$

$$D_2 \geq P_1 - P_2$$

can be replaced by the single constraint:

$$U_2 - D_2 = P_2 - P_1.$$

The argument is more economic than algebraic. The purpose with either formulation is to force $U_2 = P_2 - P_1$ if $P_2 - P_1 \geq 0$ and $D_2 = P_1 - P_2$ if $P_1 - P_2 \geq 0$. From economics, you can argue that, at the optimal solution, you will find at most one of U_2 and D_2 are greater than 0 under either formulation. If both U_2 and D_2 are greater than 0 under the second formulation, then both can be reduced by an equal amount. Thus, reducing costs without violating any constraints.

The complete formulation is:

```
MODEL:
!Minimize inventory + workforce change costs;
MIN = 700 * I1 + 700 * I2 + 700 * I3 + 700 * I4
      + 600 * U1 + 600 * U2 + 600 * U3 + 600 * U4
      + 600 * D1 + 600 * D2 + 600 * D3 + 600 * D4
      + 600 * U5 + 600 * D5;
!Initial conditions on inventory & production;
[CNDBI] I0 = 0;
[CNDBP] P0 = 40;
!Beginning inventory + production = demand + ending inventory;
[INV1] I0 + P1 = 20 + I1;
[INV2] I1 + P2 = 30 + I2;
[INV3] I2 + P3 = 50 + I3;
[INV4] I3 + P4 = 60 + I4;
!Change up - change down = prod. this period - prod. prev. period;
[CHG1] U1 - D1 = P1 - P0;
[CHG2] U2 - D2 = P2 - P1;
[CHG3] U3 - D3 = P3 - P2;
[CHG4] U4 - D4 = P4 - P3;
[CHG5] U5 - D5 = P5 - P4;
!Ending conditions;
[CNDEI] I4 = 0;
[CNDEP] P5 = 40;
END
```

The solution is:

```
Optimal solution found at step:          7
Objective value:                    43000.00
```

Variable	Value	Reduced Cost
I1	5.000000	0.000000
I2	0.000000	200.0000
I3	5.000000	0.000000
I4	0.000000	0.000000
U1	0.000000	1200.000
U2	0.000000	250.0000
U3	30.00000	0.000000

U4	0.000000	250.0000
D1	15.00000	0.000000
D2	0.000000	950.0000
D3	0.000000	1200.000
D4	0.000000	950.0000
U5	0.000000	1200.000
D5	15.00000	0.000000
I0	0.000000	0.000000
P0	40.00000	0.000000
P1	25.00000	0.000000
P2	25.00000	0.000000
P3	55.00000	0.000000
P4	55.00000	0.000000
P5	40.00000	0.000000
Row	Slack or Surplus	Dual Price
1	43000.00	-1.000000
CNDBI	0.000000	-950.0000
CNDBP	0.000000	-600.0000
INV1	0.000000	950.0000
INV2	0.000000	250.0000
INV3	0.000000	-250.0000
INV4	0.000000	-950.0000
CHG1	0.000000	600.0000
CHG2	0.000000	-350.0000
CHG3	0.000000	-600.0000
CHG4	0.000000	-350.0000
CHG5	0.000000	600.0000
CNDEI	0.000000	-1650.000
CNDEP	0.000000	600.0000

We see the solution is a mixed policy:

$$P_1 = P_2 = 25; \quad P_3 = P_4 = 55.$$

The mixed policy found by LP is \$5,000 cheaper than the best pure policy.

9.2.3 Representing Absolute Values

You may be tempted to represent the production-change costs in the above model by the expression:

$$600 * (@ABS(P1 - P0) + @ABS(P2 - P1) + ... + @ABS(P5 - P4));$$

This is mathematically correct, but computationally unwise, because it converts a linear program into a nonlinear program. Nonlinear programs are always more time consuming to solve. We have exploited the following result to obtain a linear program from an apparently nonlinear program. Subject to a certain condition, any appearance in a model of a term of the form:

$$@ABS(expression)$$

can be replaced by the term $U + D$, if we add the constraint:

$$U - D = expression.$$

The “certain condition” is that the model must be such that a small value of $@ABS(expression)$ is preferred to a large value for $@ABS(expression)$. The result is, if $expression$ is positive, then U will be equal to $expression$, whereas, if $expression$ is negative, then D will equal the negative of $expression$.

9.3 Multi-period Financial Models

In most multi-period planning problems, the management of liquid or cash-like assets is an important consideration. If you are willing to consider cash holdings as an inventory just like an inventory of any other commodity, then it is a small step to incorporate financial management decisions into a multi-period model. The key feature is, for every period, there is a constraint that effectively says, “sources of cash – uses of cash = 0”. The following simple, but realistic, example illustrates the major features of such models.

9.3.1 Example: Cash Flow Matching

Suppose, as a result of a careful planning exercise, you have concluded that you will need the following amounts of cash for the current plus next 14 years to meet certain commitments:

Year:	0	1	2	3	4	5	6	7	8	9	10	11	12	13	14
Cash (in \$1,000s)	10	11	12	14	15	17	19	20	22	24	26	29	31	33	36

A common example where such a projection is made is in a personal injury lawsuit. Both parties may reach an agreement that the injured party should receive a stream of payments such as above or its equivalent. Other examples where the above approach has been used is in designing bond portfolios to satisfy cash needs for a pension fund, or for so-called balance sheet defeasance where one kind of debt is replaced by another having the same cash flow stream.

For administrative simplicity in the personal injury example, both parties prefer an immediate single lump sum payment that is “equivalent” to the above stream of 15 payments. The party receiving the lump sum will argue that the lump sum payment should equal the present value of the stream using a low interest rate such as that obtained in a very low risk investment (i.e., a government guaranteed savings account). For example, if an interest rate of 4% is used, the present value of the stream of payments is \$230,437. The party that must pay the lump sum, however, would like to argue for a much higher interest rate. To be successful, such an argument must include evidence that such higher interest rate investments are available and are no riskier than savings accounts. The investments usually offered are government securities. Generally, a broad spectrum of such investments is available on a given day. For simplicity, assume there are just two such investments available with the following features:

Security	Current Cost	Yearly Return	Years to Maturity	Principal Repayment at Maturity
1	\$980	\$60	5	\$1000
2	\$965	\$65	12	\$1000

The paying party will offer a lump sum now with a recommendation of how much should be invested in securities 1 and 2 and in savings accounts, such that the yearly cash requirements are met with the minimum lump sum payment.

Notice in row 7, B_1 has a coefficient of 1.06. This represents the principal repayment of \$1000 plus the interest payment of \$60 measured in \$1000's. Variable S_{14} (investment of funds in a savings account after the final payment is made) appears in the problem even though at first you might think it useless to allow such an option. S_{14} is effectively a surplus cash variable in the final period. Nevertheless, it is not unusual for the solution that minimizes the lump sum payment to have cash left over at the end of the period. This is because a bond may be the most economical way of delivering funds to intermediate periods. This may cause the big principal repayment at the end of a bond's life to "overpay" the most distant periods. The solution is:

Optimal solution found at step:		14
Objective value:		195.6837
Variable	Value	Reduced Cost
L	195.6837	0.000000
B1	95.79577	0.000000
B2	90.15474	0.000000
S0	4.804497	0.000000
S1	5.604481	0.000000
S2	5.436464	0.000000
S3	3.261727	0.000000
S4	0.000000	0.1069792
S5	90.40358	0.000000
S6	80.87978	0.000000
S7	69.97503	0.000000
S8	56.63409	0.000000
S9	40.75951	0.000000
S10	22.24994	0.000000
S11	0.000000	0.1412458
S12	65.01479	0.000000
S13	34.61538	0.000000
S14	0.000000	0.3796368

Of the \$195,683.70 lump sum payment, \$10,000 goes to immediate requirements, \$4,804.50 goes into a savings account, and $0.98 \times 95,795.77 + 0.965 \times 90,154.74 = \$180,879.20$ goes into longer-term securities. Considering a wide range of investments rather than just savings accounts has reduced the amount of the lump sum payment by about \$34,750, or 15%.

In actual solutions, one may find a major fraction of the lump sum is invested in a single security. For example, appending the following constraint limits the amount invested in security 1 to half the initial lump sum:

$$0.98 B_1 - 0.5 L \leq 0.$$

An additional complication may arise due to integrality requirements on the B_1 and B_2 investments. For example, bonds can be bought only in \$1000 increments. Generally, with a modest amount of judgment, the fractional values can be rounded to neighboring integer values with no great increase in lump sum payment. For example, if B_1 and B_2 are set to 96 and 90 in the previous example, the total cost increases to \$195,726.50 from \$195,683.70. When this is done, S_{14} becomes nonzero. Specifically, the last period is overpaid by about \$40.

A sets version that places an integrality requirement on the bond purchase variables is:

```

MODEL:
! Name= PBOND, Bond portfolio/ cash matching problem: Given cash
needs in each future period, what collection of bonds should we buy
to cover these needs?;
SETS:
BOND/1..2/ : MATAT, ! Matures at period;
           PRICE, ! Purchase price;
           CAMNT, ! Coupon payout each period;
           BUY; ! Amount to buy of each bond;
PERIOD/1..15/:
  NEED, ! Cash needed each period;
SINVEST; ! Short term investment each period;
ENDSETS
DATA:
STRTE = .04; ! Short term interest rate;
MATAT = 6, 13; ! Years to maturity;
PRICE = .980, .965; ! Purchase price in thousands;
CAMNT = .060, .065; ! Coupon amount in thousands;
NEED = 10, 11, 12, 14, 15, 17, 19, 20, 22, 24,
      26, 29, 31, 33, 36; ! Cash needed in
      thousands;
ENDDATA
!-----;
MIN = LUMP;
! First period is slightly special;
LUMP =
NEED(1) + SINVEST( 1) + @SUM( BOND: PRICE * BUY);
! For subsequent periods;
@FOR( PERIOD( I) | I #GT# 1:
  @SUM( BOND( J) | MATAT( J) #GE# I:
    CAMNT( J) * BUY( J) ) +
  @SUM( BOND( J) | MATAT( J) #EQ# I: BUY( J) ) +
  ( 1 + STRTE) * SINVEST( I - 1) =
  NEED( I) + SINVEST( I);
);
! Can only buy integer bonds;
@FOR( BOND( J): @GIN( BUY( J)));;
END

```

```

Optimal solution found at step:      28
Objective value:                    195.7265
Branch count:                        3

```

Variable	Value	Reduced Cost
STRTE	0.4000000E-01	0.0000000
LUMP	195.7265	0.0000000
MATAT(1)	6.000000	0.0000000
MATAT(2)	13.00000	0.0000000
PRICE(1)	0.9800000	0.0000000
PRICE(2)	0.9650000	0.0000000
CAMNT(1)	0.6000000E-01	0.0000000
CAMNT(2)	0.6500000E-01	0.0000000
BUY(1)	96.00000	0.7622063

BUY (2)	90.00000	0.7290568
NEED (1)	10.00000	0.0000000
NEED (2)	11.00000	0.0000000
NEED (3)	12.00000	0.0000000
NEED (4)	14.00000	0.0000000
NEED (5)	15.00000	0.0000000
NEED (6)	17.00000	0.0000000
NEED (7)	19.00000	0.0000000
NEED (8)	20.00000	0.0000000
NEED (9)	22.00000	0.0000000
NEED (10)	24.00000	0.0000000
NEED (11)	26.00000	0.0000000
NEED (12)	29.00000	0.0000000
NEED (13)	31.00000	0.0000000
NEED (14)	33.00000	0.0000000
NEED (15)	36.00000	0.0000000
SINVEST (1)	4.796526	0.0000000
SINVEST (2)	5.598387	0.0000000
SINVEST (3)	5.432322	0.0000000
SINVEST (4)	3.259615	0.0000000
SINVEST (5)	0.0000000	0.8548042
SINVEST (6)	90.61000	0.0000000
SINVEST (7)	81.08440	0.0000000
SINVEST (8)	70.17778	0.0000000
SINVEST (9)	56.83489	0.0000000
SINVEST (10)	40.95828	0.0000000
SINVEST (11)	22.44661	0.0000000
SINVEST (12)	0.1944784	0.0000000
SINVEST (13)	65.05226	0.0000000
SINVEST (14)	34.65435	0.0000000
SINVEST (15)	0.4052172E-01	0.0000000

9.4 Financial Planning Models with Tax Considerations

The next example treats a slightly more complicated version of the portfolio selection problem and then illustrates how to include and examine the effect of taxes. Winston-Salem Development Management (WSDM) is trying to complete its investment plans for the next three years. Currently, WSDM has two million dollars available for investment. At six-month intervals over the next three years, WSDM expects the following income stream from previous investments: \$500,000 (six months from now); \$400,000; \$380,000; \$360,000; \$340,000; and \$300,000 (at the end of third year). There are three development projects in which WSDM is considering participating. The Foster City Development would, if WSDM participated fully, have the following cash flow stream (projected) at six-month intervals over the next three years (negative numbers represent investments, positive numbers represent income): -\$3,000,000; -\$1,000,000; -\$1,800,000; \$400,000; \$1,800,000; \$1,800,000; \$5,500,000. The last figure is its estimated value at the end of three years. A second project involves taking over the operation of some old lower-middle-income housing on the condition that certain initial repairs to it be made and that it be demolished at the end of three years. The cash flow stream for this project, if participated in fully, would be: -\$2,000,000; -\$500,000; \$1,500,000; \$1,500,000; \$1,500,000; \$200,000; -\$1,000,000.

The third project, the Disney-Universe Hotel, would have the following cash flow stream (six-month intervals) if WSDM participated fully. Again, the last figure is the estimated value at the

end of the three years: $-\$2,000,000$; $-\$2,000,000$; $-\$1,800,000$; $\$1,000,000$; $\$1,000,000$; $\$1,000,000$; $\$6,000,000$. WSDM can borrow money for half-year intervals at 3.5 percent interest per half year. At most, 2 million dollars can be borrowed at one time (i.e., the total outstanding principal can never exceed 2 million). WSDM can invest surplus funds at 3 percent per half year.

Initially, we will disregard taxes. We will formulate the problem of maximizing WSDM's net worth at the end of three years as a linear program. If WSDM participates in a project at less than 100 percent, all the cash flows of that project are reduced proportionately.

9.4.1 Formulation and Solution of the WSDM Problem

Define:

- F = fractional participation in the Foster City problem;
- M = fractional participation in Lower-Middle;
- D = participation in Disney;
- B_i = amount borrowed in period i in 1000's of dollars, $i = 1, \dots, 6$;
- L_i = amount lent in period i in 1000's of dollars, $i = 1, \dots, 6$;
- Z = net worth after the six periods in 1000's of dollars.

The problem formally is then (all numbers will be measured in units of 1000):

```

MODEL:
MAX = Z; ! Max worth at end of final period;
! Uses - sources = supply of cash in each period;
 3000 * F + 2000 * M + 2000 * D - B1 + L1 = 2000;
 1000 * F + 500 * M + 2000 * D + 1.035 * B1 - 1.03 * L1 - B2 +
L2=500;
 1800 * F - 1500 * M + 1800 * D + 1.035 * B2 - 1.03 * L2 - B3 +
L3=400;
 -400 * F - 1500 * M - 1000 * D + 1.035 * B3 - 1.03 * L3 - B4 +
L4=380;
-1800 * F - 1500 * M - 1000 * D + 1.035 * B4 - 1.03 * L4 - B5 +
L5=360;
-1800 * F - 200 * M - 1000 * D + 1.035 * B5 - 1.03 * L5 - B6 +
L6=340;
Z - 5500 * F + 1000 * M - 6000 * D + 1.035 * B6 - 1.03 * L6=300;
! Borrowing limits;
B1 <= 2000;
B2 <= 2000;
B3 <= 2000;
B4 <= 2000;
B5 <= 2000;
B6 <= 2000;
! We can invest at most 100% in a project;
F <= 1;
M <= 1;
D <= 1;
END

```

Rows 4 through 17 are the cash flow constraints for each of the periods. They enforce the requirement that *uses of cash* - *sources of cash* = 0 for each period. In the initial period, for example, L_1 uses cash, whereas B_1 is a source of cash.

The solution is:

Optimal solution found at step:	11	
Objective value:	7665.179	
Variable	Value	Reduced Cost
Z	7665.179	0.0000000
F	0.7143414	0.0000000
M	0.6372096	0.0000000
D	0.0000000	452.3816
B1	1417.443	0.0000000
L1	0.0000000	0.8788487E-02
B2	2000.000	0.0000000
L2	0.0000000	0.3343139
B3	2000.000	0.0000000
L3	0.0000000	0.2509563
B4	448.4490	0.0000000
L4	0.0000000	0.5304549E-02
B5	0.0000000	0.5149997E-02
L5	2137.484	0.0000000
B6	0.0000000	0.5000029E-02
L6	3954.865	0.0000000
Row	Slack or Surplus	Dual Price
1	7665.179	1.000000
2	0.0000000	1.819220
3	0.0000000	1.757701
4	0.0000000	1.381929
5	0.0000000	1.098032
6	0.0000000	1.060900
7	0.0000000	1.030000
8	0.0000000	1.000000
9	582.5567	0.0000000
10	0.0000000	0.3274043
11	0.0000000	0.2454662
12	1551.551	0.0000000
13	2000.000	0.0000000
14	2000.000	0.0000000
15	0.2856586	0.0000000
16	0.3627904	0.0000000
17	1.000000	0.0000000

Thus, we should try to invest or buy 0.7143414 of the Foster City project, 0.6372096 of the Middle-income project, and invest nothing in the Disney Universe project. At the end of the planning horizon, our net worth should have grown to 7,665,179.

9.4.2 Interpretation of the Dual Prices

The dual price on each of the first seven constraints is the increase in net worth in the last period resulting from an extra dollar made available in the earliest period. For example, the 1.81922 indicates an extra dollar available at the start of period 1 would increase the net worth in the last period by about \$1.82.

An extra dollar in period 5 is worth \$1.0609 at the end, because all we will do with it is invest it for two periods at three percent. Thus, it will grow to $1.03 \times 1.03 = 1.0609$ at the end.

An extra dollar in period 4 will save us from borrowing a dollar that period. Thus, we will be \$1.035 richer in period 5. We have already seen the value per extra dollar in period 5, so the value of an extra dollar in period 4 is $\$1.035 \times 1.0609 = \1.09803 .

The dual prices on the borrowing constraints can be reconciled with the rest of the dual prices as follows. Having an additional dollar in period 2 is worth \$1.7577. If this dollar were borrowed, then we would have to pay out \$1.035 in period 3, which would have an effective cost of 1.035×1.38193 . Thus, the net value in the last period of borrowing an extra dollar in period 2 is $1.7577 - 1.035 \times 1.38193 = 0.3274$, which agrees with the dual price on the borrowing constraint for period 2.

The effective interest rate or cost of capital, i , in any period t , can be found from the dual prices by deriving the rate at which one would be willing to borrow. Borrowing one dollar in period t would give us \$1 more in period t , but would require us to pay out $1 + i$ dollars in period $t + 1$. We must balance these two considerations. Consider period 1. An extra dollar is worth \$1.81922 at the end of period 6. Paying back $1 + i$ in period 2 would cost $(1 + i)$ \$1.7577 at the end of period 6. Balancing these two:

$$1.81922 = (1 + i)1.7577.$$

Solving:

$$i = 0.035.$$

This is not surprising because we are already borrowing at that rate in period 1, but not to the limit.

Applying a similar analysis to the other periods, we get the following effective rates:

Period	i	Period	i
1	0.03500	4	0.035
2	0.27190	5	0.030
3	0.25855	6	0.030

9.5 Present Value vs. LP Analysis

A standard method for evaluating the attractiveness of a project is by computing the present value of its cash flow stream. LP analysis, as we have just illustrated, is a generalization of present value (PV) analysis. The assumptions underlying PV analysis are that money can be: a) borrowed or lent, b) without limit, c) at a single interest rate. An LP model, such as that just considered, gives exactly the same recommendation as PV analysis if the same assumptions are made. LP analysis, however, allows one to have a borrowing rate different from a lending rate; a borrowing rate or lending rate that varies from period to period; and/or an upper limit on the amount borrowed or lent at a given rate.

Like PV analysis, LP analysis avoids the ambiguity of multiple rates of return that can occur when the internal rate of return is used to evaluate a project. Consider a project that requires an initial investment of \$1 million, pays back \$2.5 million after one year, and incurs a termination cost after two years of \$1.55 million. This project has two internal rates of return. One is about 13.82% per year. The other is about 36.18% per year. Is the project attractive if our cost of capital is 11% per year? Both PV and LP analysis will (correctly) reject this project if our cost of capital is 12% per year, accept the project if our cost of capital is 24% per year, and reject the project if our cost of capital is 38% per year.

9.6 Accounting for Income Taxes

Suppose we take taxes into account. Let us consider the following simplified situation. There is a tax rate of fifty percent on profit for any period. If there is a loss in a period, eighty percent can be carried forward to the next period. (Typically, tax laws put a limit on how many years a loss can be carried forward, but eighty percent may be a good approximation.)

Taxable income for each of the prospective projects as well as all existing projects is given in the table below. Note that because of factors such as depreciation, actual net cash flow may be rather different from taxable income in a period:

Period	Project			
	Foster City	Lower-Middle Housing	Disney Universe	Existing
1	-100,000	-200,000	-150,000	0
2	-300,000	-400,000	-200,000	100,000
3	-600,000	-200,000	-300,000	80,000
4	-100,000	500,000	-200,000	76,000
5	500,000	1,000,000	500,000	72,000
6	1,000,000	100,000	800,000	68,000
7	4,000,000	-1,000,000	5,000,000	60,000

To formulate a model, in this case, we need to additionally define:

P_i = profit in period i , and
 C_i = loss in period i .

The formulation is affected in two ways. First, we must append some equations that force the P_i 's and C_i 's to be computed properly, and, secondly, terms must be added to the cash flow constraints to account for the cash expended in the payment of tax.

In words, one of the tax computation equations is:

$$\text{Profit} - \text{loss} = \text{revenue} - \text{expense} - 0.8 \times (\text{last period's loss}).$$

Algebraically, this equation for period 2 is:

$$P_2 - C_2 = 100 + 0.03L_1 - 300F - 400M - 200D - 0.035B_1 - 0.8C_1,$$

or in standard form:

$$P_2 - C_2 - 0.03L_1 + 300F + 400M + 200D + 0.035B_1 + 0.8C_1 = 100.$$

The entire formulation is:

```

MAX = Z;
!Cash flow constraints, uses-sources= 0, including the 50% tax usage;
3000*F +2000*M + 2000*D - B1 + L1 + 0.5*P1=2000;
1000*F + 500*M + 2000*D+1.035*B1-1.03*L1-B2+L2+0.5*P2= 500;
1800*F -1500*M + 1800*D+1.035*B2-1.03*L2-B3+L3+0.5*P3= 400;
-400*F -1500*M - 1000*D+1.035*B3-1.03*L3-B4+L4+0.5*P4= 380;
-1800*F -1500*M - 1000*D+1.035*B4-1.03*L4-B5+L5+0.5*P5= 360;
-1800*F - 200*M - 1000*D+1.035*B5-1.03*L5-B6+L6+0.5*P6= 340;
Z-5500*F+1000*M - 6000*D+1.035*B6-1.03*L6 +0.5*P7= 300;
! The borrowing limits;
B1 <= 2000;
B2 <= 2000;
B3 <= 2000;
B4 <= 2000;
B5 <= 2000;
B6 <= 2000;
! The investing limits;
F <= 1;
M <= 1;
D <= 1;
! Taxable Profit-Loss for each period;
100*F+ 200*M+ 150*D +P1 -C1 = 0;
300*F+ 400*M+ 200*D+0.035*B1-0.03*L1+P2+0.8*C1-C2=100;
600*F+ 200*M+ 300*D+0.035*B2-0.03*L2+P3+0.8*C2-C3= 80;
100*F- 500*M+ 200*D+0.035*B3-0.03*L3+P4+0.8*C3-C4= 76;
-500*F-1000*M- 500*D+0.035*B4-0.03*L4+P5+0.8*C4-C5= 72;
-1000*F- 100*M- 800*D+0.035*B5-0.03*L5+P6+0.8*C5-C6= 68;
-4000*F+1000*M-5000*D+0.035*B6-0.03*L6+P7+0.8*C6-C7= 60;

```

The solution is:

Variable	Value	Reduced Cost
Objective value:	5899.975	
Z	5899.9750	0.0000000
F	0.4872107	0.0000000
M	1.0000000	0.0000000
D	0.0000000	945.00740
B1	1461.6320	0.0000000
L1	0.0000000	0.5111823E-02
P1	0.0000000	0.4499472
B2	2000.0000	0.0000000
L2	0.0000000	0.1960928
P2	0.0000000	0.3793084
B3	1046.9790	0.0000000
L3	0.0000000	0.3167932E-02
P3	0.0000000	0.2042549
B4	0.0000000	0.2575563E-02
L4	991.26070	0.0000000
P4	0.0000000	0.1107492
B5	0.0000000	0.2537532E-02
L5	3221.6490	0.0000000
P5	1072.6580	0.0000000

B6	0.0000000	0.2499981E-02
L6	4359.3480	0.0000000
P6	751.86020	0.0000000
P7	1139.6230	0.0000000
C1	248.72110	0.0000000
C2	696.29720	0.0000000
C3	1039.3640	0.0000000
C4	340.85670	0.0000000
C5	0.0000000	0.1091125
C6	0.0000000	0.1075000
C7	0.0000000	0.5000000
Row	Slack or Surplus	Dual Price
1	5899.9750	1.0000000
2	0.0000000	1.3218740
3	0.0000000	1.2860920
4	0.0000000	1.0678540
5	0.0000000	1.0456780
6	0.0000000	1.0302250
7	0.0000000	1.0150000
8	0.0000000	1.0000000
9	538.36780	0.0000000
10	0.0000000	0.1924019
11	953.02070	0.0000000
12	2000.0000	0.0000000
13	2000.0000	0.0000000
14	2000.0000	0.0000000
15	0.5127893	0.0000000
16	0.0000000	573.56060
17	1.0000000	0.0000000
18	0.0000000	-0.2109901
19	0.0000000	-0.2637376
20	0.0000000	-0.3296720
21	0.0000000	-0.4120900
22	0.0000000	-0.5151125
23	0.0000000	-0.5075000
24	0.0000000	-0.5000000

Notice tax considerations cause a substantial change in the solution. More funds are placed into the lower-middle income housing project, *M*, and fewer funds are invested in the Foster City project, *F*. Project *M* has cash flows, which help to smooth out the stream of yearly profits.

9.7 Dynamic or Multi-period Networks

Thus far we have viewed network problems mainly as either a steady state or a one period problem. For example, in a pipeline network model, the solution can be interpreted as either the flow of material that occurs continuously day after day, or as a flow that occurs for one period and then stops. In many real systems, however, we are interested in a flow that varies from period to period, i.e., we are interested in multi-period or dynamic solutions. In these multi-period flows we also want to take into account that it may take several periods for flow to travel over an arc. Example dynamic networks are: a) river systems with various dams where we are interested in the amount of water to be spilled over the dam each period so as to satisfy various criteria regarding lake and river levels, river flows, and hydroelectric generation needs. A period might be a day, an arc might be the river section from one dam to the next, and it may take several periods for water to flow from one dam to the next. b) evacuation of a threatened facility or region as part of disaster planning, where we are interested in what routes people should take so that a large number of people escape in a short amount of time. For a building evacuation, a period might be 10 seconds, an arc may be a hallway, or a stairwell from one door to the next. Each arc may have a capacity limit of how many people can enter it per period, c) fleet routing of airplanes or trucks, where each arc in the network is a movement that must be made by either a truck or an airplane. The lead time of an arc is the length of time that it takes a vehicle to traverse the arc.

To represent a dynamic network algebraically, we need to define:

Parameters:

$L(i,j)$ = lead time, in periods, for flow to travel from node i to node j in the arc from i to j ,

Variables:

x_{ijt} = flow entering arc ij at i in period t , and therefore exiting at j in period $t+L(i,j)$,
 V_{jt} = inventory remaining at node j at the end of period t ,

The basic node balance equation says that (inventory at node k at the end of period t) = (ending inventory at k in the preceding period) + (arriving shipments) – (shipments out of k in t), or algebraically:

$$V_{kt} = V_{k,t-1} + \sum_i x_{ik(t-L(i,k))} - \sum_j x_{kj,t}$$

Example:

We will illustrate the main ideas with an evacuation problem for a building. Complete details can be found in the set based LINGO model: `evacu8.lng` in the Applications Library at www.lindo.com. Figure 9.1 gives the numeric details of a building for which we want to plan evacuation routes. The nodes are places where people are or can congregate. The arcs correspond to hallways, stairwells, etc. The number of people to be evacuated from each node in the network appears in italicized font below each node. A period is a 10 second interval. The italicized number appearing below each arc is the number of periods it takes to traverse the arc. The number appearing above each arc is the upper limit on the number of people that can enter an arc per period. The number appearing above each node is the upper limit on the number of people that can be waiting at a node.

Figure 9.1 Building Evacuation Network

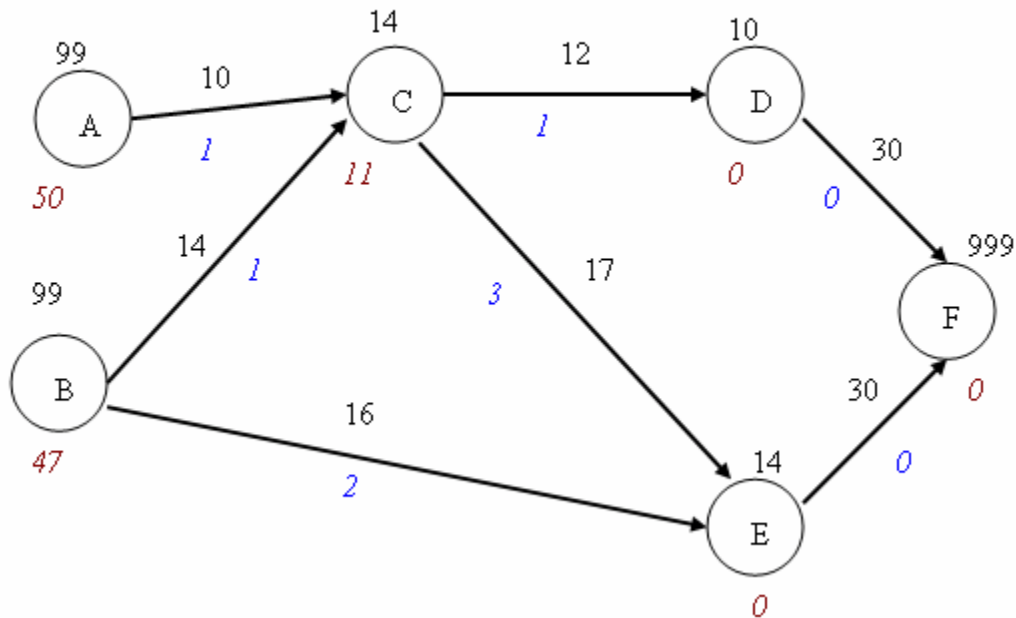

Node F corresponds to the outside world. For example, the fastest that one of the 50 people at node A can get to the safety of the outside world is in 2 periods by taking the path A, C, D, F. Not all the people at A can make it this fast, however, because the arc from C to D can handle only 12 people per period. Also, people from B may also try to use arc C, D. Arc (C,E) with its long lead time of three periods but relatively high capacity of 17 might correspond to a long, wide corridor, whereas arc (A,C) with its short lead time but low capacity might correspond to a short narrow stairwell.

What should be our objective? An obvious one is to minimize the number of periods that it takes to evacuate all people. An interesting challenge is to see if you can do it in at most 70 seconds for the above problem. Perhaps a more refined objective is to maximize the number of people who get out quickly. If $X_{i_j_t}$ is the number of people moving from i to j starting in period t , and realizing that node F is the outside world, we would like $X_{D_F_1} + X_{E_F_1}$ to be large, and $X_{D_F_9} + X_{E_F_9}$ to be much smaller. The objective that we will in fact use is:

$$\text{Max} = 10*(X_{D_F_1} + X_{E_F_1}) + 9*(X_{D_F_2} + X_{E_F_2}) \\ + 8*(X_{D_F_3} + X_{E_F_3}) + 7*(X_{D_F_4} + X_{E_F_4}) + \text{etc.}$$

That is, we attach a desirable weight of 10 to getting people out in period 1, a weight of 9 to getting them out in period 2, etc. The model `evacu8.lng` is written in very general SETS form. If you want to see what the actual objective (as shown above) or constraints look like for the given data set, click on LINGO | Generate | Display model.

Suppose you allow 10 periods for our model. We do not draw the corresponding multiperiod network, but you can think of drawing it as follows. Get yourself a very wide sheet of paper and make 10 copies, side by side of the above network. Then unhook the arrow end of each arc (i, j) and reconnect it $L(i, j)$ subnetworks later. The main, nontrivial constraints in this network model are the flow balance constraints at each node each period. For example, the constraint for node E in period 5 is:

$$[\text{BAL_E_5}] - X_{B_E_3} - X_{C_E_2} + X_{E_F_5} - V_{E_4} + V_{E_5} = 0;$$

This is equivalent to:

$$V_{E_5} = V_{E_4} + X_{B_E_3} + X_{C_E_2} - X_{E_F_5};$$

In words, this says that at the end of period 5, the number of people at node E equals the number there at the end of period 4, plus people that left node B for E two periods ago, plus the number of people that left node C for E three periods ago, minus the number of people that left node E in period 5 for node F.

In general SETS form in `evacu8.lng`, this constraint is written as:

```
! For every node k and time period t;
@FOR( NXT( k, t) | t #GT# 1:
[BAL] V(k, t) = V(k, t-1) - @SUM(NXN(k, j) : X(k, j, t))
      +@SUM(NXN(i, k) | t-LT(i, k) #GT# 0: X(i, k, t-LT(i, k)));
);
```

where the set `NXT(,)` is the set of all node k , time period t combinations, and the set `NXN(,)` is the set of all from-to arcs k, j that exist in the network.

The model is completed by adding the upper bound constraints on the number of people at each node each period, and the upper bound constraints on the number of people traveling on each arc each period. For example, the flow upper bound on the arc from B to E in period 4 is:

$$[\text{UFLO_B_E_4}] X_{B_E_4} \leq 16;$$

The upper bound on the number of people at node D at the end period 6 is:

$$[\text{USTOR_D_6}] V_{D_6} \leq 10;$$

If you solve `evacu8.lng`, you will see that you can in fact evacuate the building in 70 seconds. For simplicity and ease of direction, e.g. in terms of placement of “Exit This Way” signs, it might be desirable that the solution have all people at a given node evacuate over the same route. You may wish to check whether the solution satisfies this additional “administrative” constraint. Another example of a dynamic network, this time for a hydroelectric river system can be found in the model `dampoold.lng`. For a production example, see `mrpcap.lng`.

9.8 End Effects

Most multi-period planning models “chop” off the analysis at some finite time in the future. The manner in which this chopping off is done can be important. In general, we care about the state in which things are left at the end of a planning model (e.g., inventory levels and capital investment). If we arbitrarily terminate our planning model at year five in the future, then an optimal solution to our model may, in reality, be an optimal solution to how to go out of business in five years. Grinold (1983) provides a comprehensive discussion of various methods for mitigating end-of-horizon effects. Some of the options for handling the end effect are:

- a) *Truncation*. Simply drop from the model all periods beyond a chosen cutoff point.
- b) *Primal limits*. Place reasonable limits on things such as inventory level at the end of the final period.
- c) *Salvage values/ dual prices*. Place reasonable salvage values on things such as inventory level at the end of the final period.
- d) *Infinite final period*. Let the final period of the model represent a period of infinite length for which the same decision applies throughout the period. Net present value discounting is used in the objective function to make the final period comparable to the earlier finite periods. This is the approach used by Carino et al. (1994) in their model of the Yasuda Kasai Company, Peiser and Andrus in their model of Texas real estate development, and by Eppen, Martin, and Schrage (1988) in their model of General Motors.

9.8.1 Perishability/Shelf Life Constraints

Many products, food products in particular, are perishable. It is important to take into account the fact the product can be stored in inventory for only a modest length of time. For example, blood for blood transfusions can be stored for at most 21 days. If there is a single level of production, then this consideration is easy to represent. Define: d_t = demand in period t (given), and the variables: P_t = production in period t , and I_t = inventory at the end of period t . Then, the standard inventory balance constraint is:

$$I_{t-1} + P_t = d_t + I_t$$

If product can be carried for one period before it is discarded, then it is clear that we should add the constraint: $I_t \leq d_{t+1}$. In general, if product can be carried in inventory for at most k periods, then we add the constraint: $I_t \leq d_{t+1} + d_{t+2} \dots + d_{t+k}$.

9.8.2 Startup and Shutdown Costs

In the electric power generation industry, there is a decision problem known as the unit commitment problem. As the power demanded over the course of a day varies, the power generation company must decide which power units to start up as the demand increases and which to shutdown as demand decreases. A major concern is that there may be a significant cost to startup a generator, regardless of how long it runs. It is usually the case that the unit that is more efficient at producing power (e.g., a coal-fired unit) may, however, cost more to startup than say a gas-fired unit. Thus, if an extra burst of power is needed for only a short interval of time, it may be more cost effective to start up and run the gas-fired unit. A similar cost structure was encountered by Eppen, Martin, and Schrage(1988) in planning startup and shutdown of automotive plants. The typical way of representing startup costs is with the following two sets of variables: $y_{it} = 1$ if unit i is operating in period t , else 0; $z_{it} = 1$ if unit i is started in period t , else 0;

The crucial constraints are then:

$$z_{it} \geq y_{it} - y_{it-1}.$$

Thus, if $y_{it} = 1$, but $y_{it-1} = 0$, then z_{it} is forced to be 1. Shut down costs, if they need to be treated separately, can be handled in a similar fashion.

9.9 Non-optimality of Cyclic Solutions to Cyclic Problems

In some situations, such as when modeling the end of the planning horizon as above, it is reasonable to assume demand is cyclic (e.g., it repeats forever in a weekly cycle). A natural question to ask is

whether an optimal policy will have the same cycle length. We shall see that the answer may be 'no'. That is, even though demand has the same pattern, week-in and week-out, the most profitable policy need not have a weekly cycle. It may be optimal to behave differently from week to week.

In order to illustrate, let us reconsider the fleet routing and assignment problem introduced in chapter 8. We augment the original data with data on the profitability of two aircraft types for each flight:

Flight	Origin	Dest.	Depart	Arrive	Profit contribution (\$100)	
					MD90	B737
F221	ORD	DEN	800	934	115	111
F223	ORD	DEN	900	1039	109	128
F274	LAX	DEN	800	1116	129	104
F105	ORD	LAX	1100	1314	135	100
F228	DEN	ORD	1100	1423	125	102
F230	DEN	ORD	1200	1521	132	105
F259	ORD	LAX	1400	1609	112	129
F293	DEN	LAX	1400	1510	105	131
F412	LAX	ORD	1400	1959	103	135
F766	LAX	DEN	1600	1912	128	105
F238	DEN	ORD	1800	2121	128	101

For example, on flight pattern 221 an MD90 aircraft is more profitable than a B737 (\$11,500 vs. \$11,100), whereas a B737 is substantially more profitable (\$12,900 vs. \$11,200) on flight pattern 259. The above pattern of flights is to be covered every day. Suppose that we have seven MD90's available, but only one B737 available to cover these flights. As before, we assume no deadheading. First, we assume that we will use a solution with a cycle of one day. An appropriately modified model from chapter 8 is:

```

MODEL:
SETS: ! Fleet routing and assignment (FLEETRAT);
CITY ;; ! The cities involved;
ACRFT: ! Aircraft types;
FCOST, ! Fixed cost per day of this type;
FSIZE; ! Max fleet size of this type;
FLIGHT;;
FXCXC( FLIGHT, CITY, CITY) :
DEPAT, ! Flight departure time;
ARVAT; ! arrival time at dest.;
AXC( ACRFT, CITY):
OVNITE; ! Number staying overnight by type, city;
AXF( ACRFT, FXCXC):
X, ! Number aircraft used by type, flight;
PC; ! Profit contribution by type, flight;
ENDSETS
DATA:
CITY = ORD DEN LAX;
ACRFT, FCOST, FSIZE =
MD90 .01 7
B737 .01 1;
FLIGHT = F221 F223 F274 F105 F228 F230 F259 F293 F412 F766 F238;

```



```

FXCXC, DEPAT, ARVAT =
!   Flight  Origin  Dest.  Depart  Arrive;
      F221  ORD    DEN    800    934
      F223  ORD    DEN    900    1039
      F274  LAX    DEN    800    1116
      F105  ORD    LAX    1100   1314
      F228  DEN    ORD    1100   1423
      F230  DEN    ORD    1200   1521
      F259  ORD    LAX    1400   1609
      F293  DEN    LAX    1400   1510
      F412  LAX    ORD    1400   1959
      F766  LAX    DEN    1600   1912
      F238  DEN    ORD    1800   2121;

PC = ! Profit contribution of each vehicle*flight combo;
      115    109    129    135    125    132
      112    105    103    128    128
      111    128    104    100    102    105
      129    131    135    105    101;

ENDDATA
!-----;
! Maximize profit contribution from flights minus
  overhead cost of aircraft in fleet;
MAX = @SUM( AXF( I, N, J, K): PC( I, N, J, K) * X( I, N, J, K))
      - @SUM( AXC( I, J): FCOST( I) * OVNITE( I, J));
! At any instant, departures in particular, the number of
  cumulative arrivals must be >= number of cumulative departures;
! For each flight of each aircraft type;
@FOR( ACREFT( I):
  @FOR( FXCXC( N, J, K):
! Aircraft on ground in morning +
  number aircraft arrived thus far >=
  number aircraft departed thus far;
  OVNITE( I, J) +
  @SUM( FXCXC( N1, J1, K1) | K1 #EQ# J #AND#
        ARVAT( N1, J1, K1) #LT# DEPAT( N, J, K):
        X( I, N1, J1, J)) >=
  @SUM( FXCXC( N1, J1, K1) | J1 #EQ# J #AND#
        DEPAT( N1, J1, K1) #LE# DEPAT( N, J, K):
        X( I, N1, J, K1));
  ););
! This model does not allow deadheading, so at the end of the day,
  arrivals must equal departures;
@FOR( ACREFT( I):
  @FOR( CITY( J):
    @SUM( AXF( I, N, J1, J): X( I, N, J1, J)) =
    @SUM( AXF( I, N, J, K): X( I, N, J, K));
  );
);
! Each flight must be covered;
@FOR( FXCXC( N, J, K):
  @SUM( AXF( I, N, J, K): X( I, N, J, K)) = 1;
);

```

```

! Fleet size limits;
  @FOR( ACRFT( I):
    @SUM( AXC( I, J): OVNITE( I, J) ) <= FSIZE( I);
  );
! Fractional planes are not allowed;
  @FOR( AXF: @GIN( X); );
END

```

It has the solution:

```

Global optimal solution found at step:          106
Objective value:                             1323.940

```

Variable	Value
X(MD90, F221, ORD, DEN)	1.000000
X(MD90, F223, ORD, DEN)	1.000000
X(MD90, F274, LAX, DEN)	1.000000
X(MD90, F105, ORD, LAX)	1.000000
X(MD90, F228, DEN, ORD)	1.000000
X(MD90, F230, DEN, ORD)	1.000000
X(MD90, F259, ORD, LAX)	1.000000
X(MD90, F412, LAX, ORD)	1.000000
X(MD90, F238, DEN, ORD)	1.000000
X(B737, F293, DEN, LAX)	1.000000
X(B737, F766, LAX, DEN)	1.000000

The daily profit contribution of this solution is $1323.94 * 100 = \$132,394$ per day. Notice that our single B737 flies from *DEN* at 2 pm to *LAX* as flight 293, and then departs *LAX* at 4 pm for *DEN* as flight 766. The above model requires that at the beginning of each day we must have the same number of MD90's and B737's at a given airport as on every other day. Just for reference, if you solve the above model with no B737's available, the profit contribution is \$132,094. So, the B737 seems to be worth only \$200 per day.

Can we do better if we allow a two-day cycle in the solution? We can try by changing the input to the model as in the model below. Effectively, we have given two days worth of demand, denoting the second day's flights by an *S*, vs. the *F* denoting the flights on the first day. Otherwise, the model is identical. The profit of this two day solution should be at least $2 * 132,394 = \$264,788$:

```

MODEL:
SETS: ! Fleet routing and assignment (FLEETRAT);
  CITY ;; ! The cities involved;
  ACRFT: ! Aircraft types;
  FCOST, ! Fixed cost per day of this type;
  FSIZE; ! Max fleet size of this type;
  FLIGHT;;
  FXCXC( FLIGHT, CITY, CITY) :
  DEPAT, ! Flight departure time;
  ARVAT; ! arrival time at dest.;
  AXC( ACRFT, CITY):
  OVNITE; ! Number staying overnight by type, city;
  AXF( ACRFT, FXCXC):
  X, ! Number aircraft used by type, flight;
  PC; ! Profit contribution by type, flight;
ENDSETS

```

```

DATA:
CITY = ORD DEN LAX;
ACRFT, FCOST, FSIZE =
MD90 .01 7
B737 .01 1;
FLIGHT = F221 F223 F274 F105 F228 F230 F259 F293 F412 F766 F238
S221 S223 S274 S105 S228 S230 S259 S293 S412 S766 S238;
FXCXC, DEPAT, ARVAT =
! Flight Origin Dest. Depart Arrive;
F221 ORD DEN 800 934
F223 ORD DEN 900 1039
F274 LAX DEN 800 1116
F105 ORD LAX 1100 1314
F228 DEN ORD 1100 1423
F230 DEN ORD 1200 1521
F259 ORD LAX 1400 1609
F293 DEN LAX 1400 1510
F412 LAX ORD 1400 1959
F766 LAX DEN 1600 1912
F238 DEN ORD 1800 2121
S221 ORD DEN 3200 3334
S223 ORD DEN 3300 3439
S274 LAX DEN 3200 3516
S105 ORD LAX 3500 3714
S228 DEN ORD 3500 3823
S230 DEN ORD 3600 3921
S259 ORD LAX 3800 4009
S293 DEN LAX 3800 3910
S412 LAX ORD 3800 4359
S766 LAX DEN 4000 4312
S238 DEN ORD 4000 4521;
PC = ! Profit contribution of each vehicle*flight combo;
115 109 129 135 125 132
112 105 103 128 128
115 109 129 135 125 132
112 105 103 128 128
111 128 104 100 102 105
129 131 135 105 101
111 128 104 100 102 105
129 131 135 105 101;
ENDDATA

```

Now, the solution is:

Global optimal solution found at step: 103
Objective value: 2718.930

Variable	Value
X(MD90, F221, ORD, DEN)	1.000000
X(MD90, F223, ORD, DEN)	1.000000
X(MD90, F274, LAX, DEN)	1.000000
X(MD90, F105, ORD, LAX)	1.000000
X(MD90, F228, DEN, ORD)	1.000000
X(MD90, F230, DEN, ORD)	1.000000
X(MD90, F259, ORD, LAX)	1.000000
X(MD90, F293, DEN, LAX)	1.000000
X(MD90, F766, LAX, DEN)	1.000000
X(MD90, F238, DEN, ORD)	1.000000
X(MD90, S221, ORD, DEN)	1.000000
X(MD90, S274, LAX, DEN)	1.000000
X(MD90, S105, ORD, LAX)	1.000000
X(MD90, S228, DEN, ORD)	1.000000
X(MD90, S230, DEN, ORD)	1.000000
X(MD90, S259, ORD, LAX)	1.000000
X(MD90, S412, LAX, ORD)	1.000000
X(MD90, S766, LAX, DEN)	1.000000
X(MD90, S238, DEN, ORD)	1.000000
X(B737, F412, LAX, ORD)	1.000000
X(B737, S223, ORD, DEN)	1.000000
X(B737, S293, DEN, LAX)	1.000000

Notice that our profit, $2718.93 * 100 = \$271,893$ is more than twice the profit of the one day solution, $2 * 132,394 = \$264,788$. How did we arrive at this happy situation? Notice how the B737 is used. On the first day, it flies from *LAX* to *ORD* via flight 412. On the second day, it flies from *ORD* to *DEN* via flight 223 and then from *DEN* back to *LAX* via flight 293. It is only on the second day that it is back where it started, *LAX*. All three flights are very profitable for the B737 relative to the MD90. By allowing a two-day cycle, the B737 is able to cover these very profitable flights at least half of the time. Thus, even though the demand pattern has a one day cycle, it is profitable to allow the solution to have a two day cycle.

A good discussion of how to avoid the temptation to restrict solutions can be found in the book on “conceptual blockbusting” by Adams (1986). Orlin (1982) gives a more detailed analysis of the cyclic vehicle routing problem.

9.10 Problems

1. The Izza Steel Company of Tokyo has predicted delivery requirements of 3,000, 6,000, 5,000, and 2,000 tons of steel in the next four periods. Current workforce is at the 4,000 tons per period level. At the moment, there is 500 tons of steel in stock. At the end of the four periods, Izza would like its inventory position to be back at 500 tons. Regular time workforce has a variable cost of \$100 per ton. Overtime can be hired in any period at a cost of \$140 per ton. Regular time workforce size can be increased from one period to the next at a cost of \$300 per ton of change in capacity. It can be decreased at a cost of \$80 per ton. There is a charge of \$5 per ton for inventory at the end of each period. Izza would like the regular time workforce to be at the 3,000-ton level at the end of the four periods.
 - a) Formulate Izza's problem as a linear program.
 - b) What assumption does your model make about idle workforce?
2. An airline predicts the following pilot requirements for the next five quarters: 80, 90, 110, 120, 110. Current staff is 90 pilots. The question of major concern is the number of pilots to hire in each of the next five quarters. A pilot must spend the quarter in which she is hired in training. The line's training facilities limit the number of pilots in training to at most 15. Further, the training of pilots requires the services of experienced pilots at the ratio of 5 to 1 (e.g., five pilots in training require one experienced pilot). An experienced pilot so assigned cannot be used to satisfy regular requirements. The cost of hiring and training a pilot is estimated at \$20,000 exclusive of the experienced pilot time required. Experienced pilots cost \$25,000 per quarter. Company policy does not include firing pilots.
 - a) What are the variables?
 - b) Formulate a model for determining how many pilots to hire in each period.
3. The Touted de Suite Candy Company includes in its product line a number of different mixed nut products. The Chalet nut mix is required to have no more than 25 percent peanuts and no less than 40 percent almonds.

The nuts available, their prices, and their availabilities this month are as follows:

Nut	Price	Availability
Peanuts	20¢/lb.	400 lbs.
Walnuts	35¢/lb.	No limit
Almonds	50¢/lb.	200 lbs.

The Chalet mix sells for 80 cents per pound. At most, 700 pounds can be mixed per month in questions (a), (b), and (c).

- a) Formulate the appropriate model for this problem.
- b) Touted de Suite would like to incorporate into the analysis its second major mixed nut line, the Hovel line. The Hovel mix can contain no more than 60 percent peanuts and no less than 20 percent almonds. Hovel sells for 40 cents per pound. Modify your model appropriately.

- c) Toute de Suite would like to incorporate next month's requirements into the analysis. The expected situation next month is:

Nut	Price	Requirement (Availability)
<i>Peanuts</i>	19¢/lb.	500 lbs
<i>Walnuts</i>	36¢/lb.	No limit
<i>Almonds</i>	52¢/lb.	180 lbs.
<i>Chalet</i>	81¢/lb.	
<i>Hovel</i>	39¢/lb.	

It cost 2 cents per pound to store nuts (plain or mixed) for one month. Because of a contract commitment, at least 200 pounds of Chalet mix must be sold next month. Modify your model appropriately.

4. If two parties to a financial agreement, A and B , want the agreement to be treated as a lease for tax purposes, the payment schedule typically must satisfy certain conditions specified by the taxing agency. Suppose P_i is the payment A is scheduled to make to B in year i of a seven-year agreement. Parties A and B want to choose at the outset a set of P_i 's to satisfy a tax regulation that no payment in any given period can be less than two-thirds of the payment in any later period. Show the constraints for period i to enforce this lower bound on P_i . Use as few constraints per period as possible.
5. One of the options available to a natural gas utility is the renting of a storage facility, so it can buy gas at a cheap rate in the summer and store it until possibly needed in the winter. There is a yearly fee of \$80,000 for each year the facility is rented. There is an additional requirement that, if the utility starts renting the facility in year t , it must also rent it for at least the next three years. The gas utility has a long range planning model with a variable $x_t = 1$ if the utility rents the storage facility in year t , 0 otherwise; $y_t = 1$ if the utility starts renting in period t ; and $z_t = 1$ if the utility stops renting after period t , for $t = 1$ to 25. It is not clear whether or not this facility should be rented. Show how to represent this fee structure in an LP/IP model.
6. Below is the formulation of a cash flow matching problem, where the B variables represent investments in bonds and the S variables represent investment in savings for one period. The right-hand sides are the cash requirements for the various years.

```

MIN = L;
[P0]L -.98 * B1 - .965 * B2 - S0 = 10;
[P01] .06 * B1 + .065 * B2 + 1.04 * S0 - S1 = 11;
[P02] .06 * B1 + .065 * B2 + 1.04 * S1 - S2 = 12;
[P03] .06 * B1 + .065 * B2 + 1.04 * S2 - S3 = 14;
[P04] .06 * B1 + .065 * B2 + 1.04 * S3 - S4 = 15;
[P05] 1.06 * B1 + .065 * B2 + 1.04 * S4 - S5 = 17;
[P06] .065 * B2 + 1.04 * S5 - S6 = 19;
[P07] .065 * B2 + 1.04 * S6 - S7 = 20;
[P08] .065 * B2 + 1.04 * S7 - S8 = 22;
[P09] .065 * B2 + 1.04 * S8 - S9 = 24;
[P10] .065 * B2 + 1.04 * S9 - S10 = 26;
[P11] .065 * B2 + 1.04 * S10 - S11 = 29;
[P12] 1.065 * B2 + 1.04 * S11 - S12 = 31;
END

```

- a) The option to borrow at seven percent per period for a term of one period has become available in every period. Show the modification in the above model for the periods with right-hand sides of 15, 17, and 19. Denote the borrowing variables by M_0 , M_1 , etc.
- b) Would this option in fact be attractive in the above model in any period?
- c) Almost all the parties involved were happy with this model until the Internal Revenue Service (IRS) suddenly became interested. The IRS has made the judgment that the initial endowment in the very first period may be tax-free. However, thereafter, the regular tax laws apply. Upon further inquiry, the IRS responded that regular income is taxed at 37 percent and capital gains at 15 percent.

We now want to find the initial lump sum such that, after taxes have been paid each period, we can still cover the right-hand side requirements. For simplicity, assume taxes are paid in the same period as the income being taxed. Show how rows P_04 and P_05 are altered by this unpleasant new reality (Disregard (a) and (b) above in answering.).

10

Blending of Input Materials

10.1 Introduction

In a blending problem, there are:

- 1) Two or more input raw material commodities;
- 2) One or more qualities associated with each input commodity;
- 3) One or more output products to be produced by blending the input commodities, so certain output quality requirements are satisfied.

A good approximation is usually that the quality of the finished product is the weighted average of the qualities of the products going into the blend.

Some examples are:

Output Commodity	Qualities	Raw Materials
Feed	Moisture, density, fraction foreign material, fraction damaged	Various types of feeds, e.g., by source.
Food	Protein, carbohydrate, fat content	Corn, oats, soybeans, meat types
Gasoline	Octane, volatility, vapor pressure	Types of crude oil refinery products
Metals	Carbon, manganese, chrome content	Metal ore, scrap metals
Grain for export	Moisture, percent foreign material, percent damaged	Grain from various suppliers
Coal for sale	Sulfur, BTU, ash, moisture content	Coal from Illinois, Wyoming, Pennsylvania
Wine	Vintage, variety, region	Pure wines of various regions
Bank balance sheet	Proportion of loans of various types, average duration of loans and investment portfolios	Types of loans and investments available

Blending models are used most frequently in three industries:

- 1) Feed and food (e.g., the blending of cattle feed, hotdogs, etc.);
- 2) Metals industry (e.g., the blending of specialty steels and nonferrous alloys, especially where recycled or scrap materials are used);
- 3) Petroleum industry (e.g., the blending of gasolines of specified octanes and volatility).

The market price of a typical raw material commodity may change significantly over the period of a month or even a week. The smart buyer will want to buy corn, for example, from the cheapest supplier. The even smarter buyer will want to exploit the fact that, as the price of corn drops relative to soybeans, the buyer may be able to save some money by switching to a blend that uses more corn.

Fields and McGee (1978) describe a feed blending LP for constructing low cost rations for cattle in a feedlot. Feedlot managers used this particular model at the rate of over 1,000 times per month. Schuster and Allen (1998) discuss the blending of grape juice at Welch's, Inc. The qualities of concern in grape juice are sweetness, acidity, and color. A blending problem must be solved at least once each season based upon how much of each type of grape is harvested by Welch's suppliers. Long term contracts require Welch's to take all of each supplier's harvest.

A recent success story in the steel industry has been the mini-mill. These small mills use mostly recyclable scrap steels to be charged into an electric furnace. The blending problem, in this case, is to decide what combination of scrap types to use to satisfy output quality requirements for specified products such as reinforcing bars, etc.

The first general LP to appear in print was a blending or diet problem formulated by George Stigler (1945). The problem was to construct a "recipe" from about 80 foods, so the mix satisfied about a dozen nutritional requirements. For example, percent protein greater than 5 percent, percent cellulose less than 40 percent, etc. When Stigler formulated this problem, the Simplex method for solving LPs did not exist. Therefore, it was not widely realized that this "diet problem" was just a special case of this wider class of problems. Stigler, realizing its generality, stated: "...there does not appear to be any direct method of finding the minimum of a linear function subject to linear conditions." The solution he obtained to his specific problem by ingenious arguments was within a few cents of the least cost solution determined later when the Simplex method was invented. Both the least cost solution and Stigler's solution were not exactly haute cuisine. Both consisted largely of cabbage, flour and dried navy beans with a touch of spinach for excitement. It is not clear that anyone would want to exist on this diet or even live with someone who was on it. These solutions illustrate the importance of explicitly including constraints that are so obvious they can be forgotten. In this case, they are palatability constraints.

10.2 The Structure of Blending Problems

Let us consider a simple feed blending problem. We must produce a batch of cattle feed having a protein content of at least 15%. Mixing corn (which is 6% protein) and soybean meal (which is 35% protein) produces this feed.

In words, the protein constraint is:

$$\frac{\text{bushels of protein in mix}}{\text{bushels in mix}} \geq 0.15$$

If C is the number of bushels of corn in the mix and S is the number of bushels of soybean meal, then we have:

$$\frac{0.06C + 0.35S}{C + S} \geq 0.15$$

At first glance, it looks like we have trouble. This constraint is not linear. If, however, we multiply both sides by $C + S$, we get:

$$0.06C + 0.35S \geq 0.15(C + S)$$

or, in standard form, finally:

$$-0.09C + 0.20S \geq 0.$$

Constraints on additional characteristics (i.e., fat, carbohydrates and even such slightly nonlinear things as color, taste, and texture) can be handled in similar fashion.

The distinctive feature of a blending problem is that the crucial constraints, when written in intuitive form, are *ratios* of linear expressions. They can be converted to linear form by multiplying through by the denominator. Ratio constraints may also be found in “balance sheet” financial planning models where a financial institution may have ratio constraints on the types of loans it makes or on the average duration of its investments.

The formulation is slightly more complicated if the blending aspect is just a small portion of a larger problem in which the batch size is a decision variable. The second example in this section will consider this complication. The first example will consider the situation where the batch size is specified beforehand.

10.2.1 Example: The Pittsburgh Steel Company Blending Problem

The Pittsburgh Steel (PS) Co. has been contracted to produce a new type of very high carbon steel which has the following tight quality requirements:

	At Least	Not More Than
Carbon Content	3.00%	3.50%
Chrome Content	0.30%	0.45%
Manganese Content	1.35%	1.65%
Silicon Content	2.70%	3.00%

PS has the following materials available for mixing up a batch:

	Cost per Pound	Percent Carbon	Percent Chrome	Percent Manganese	Percent Silicon	Amount Available
Pig Iron 1	0.0300	4.0	0.0	0.9	2.25	unlimited
Pig Iron 2	0.0645	0.0	10.0	4.5	15.00	unlimited
Ferro- Silicon 1	0.0650	0.0	0.0	0.0	45.00	unlimited
Ferro- Silicon 2	0.0610	0.0	0.0	0.0	42.00	unlimited
Alloy 1	0.1000	0.0	0.0	60.0	18.00	unlimited
Alloy 2	0.1300	0.0	20.0	9.0	30.00	unlimited
Alloy 3	0.1190	0.0	8.0	33.0	25.00	unlimited
Carbide (Silicon)	0.0800	15.0	0.0	0.0	30.00	20 lb.
Steel 1	0.0210	0.4	0.0	0.9	0.00	200 lb.
Steel 2	0.0200	0.1	0.0	0.3	0.00	200 lb.
Steel 3	0.0195	0.1	0.0	0.3	0.00	200 lb.

An one-ton (2000-lb.) batch must be blended, which satisfies the quality requirements stated earlier. The problem now is what amounts of each of the eleven materials should be blended together to minimize the cost, but satisfy the quality requirements. An experienced steel man claims the least cost mix will not use any more than nine of the eleven available raw materials. What is a good blend? Most of the eleven prices and four quality control requirements are negotiable. Which prices and requirements are worth negotiating?

Note the chemical content of a blend is simply the weighted average of the chemical content of its components. Thus, for example, if we make a blend of 40% Alloy 1 and 60% Alloy 2, the manganese content is $(0.40) \times 60 + (0.60) \times 9 = 29.4$.

10.2.2 Formulation and Solution of the Pittsburgh Steel Blending Problem

The PS blending problem can be formulated as an LP with 11 variables and 13 constraints. The 11 variables correspond to the 11 raw materials from which we can choose. Four constraints are from the upper usage limits on silicon carbide and steels. Four of the constraints are from the lower quality limits. Another four constraints are from the upper quality limits. The thirteenth constraint is the requirement that the weight of all materials used must sum to 2000 pounds.

If we let P_1 be the number of pounds of Pig Iron 1 to be used and use similar notation for the remaining materials, the problem of minimizing the cost per ton can be stated as:

```

MIN =      0.03 * P1 + 0.0645 * P2 + 0.065 * F1 + 0.061 * F2 + 0.1 * A1
+ 0.13 * A2 + 0.119 * A3 + 0.08 * CB + 0.021 * S1 + 0.02 * S2 +
0.0195 * S3;
! Raw material availabilities;
CB <= 20;
S1 <= 200;
S2 <= 200;
S3 <= 200;
! Quality requirements on;
! Carbon content;
.04 * P1 + 0.15 * CB + 0.004 * S1 + 0.001 * S2 + 0.001 * S3 >= 60;
.04 * P1 + 0.15 * CB + 0.004 * S1 + 0.001 * S2 + 0.001 * S3 <= 70;
! Chrome content;
0.1 * P2 + 0.2 * A2 + 0.08 * A3 >= 6;
0.1 * P2 + 0.2 * A2 + 0.08 * A3 <= 9;
! Manganese content;
0.009 * P1 + 0.045 * P2 + 0.6 * A1 + 0.09 * A2 + 0.33 * A3 + 0.009 *
S1 + 0.003 * S2 + 0.003 * S3 >= 27;
0.009 * P1 + 0.045 * P2 + 0.6 * A1 + 0.09 * A2 + 0.33 * A3 + 0.009 *
S1 + 0.003 * S2 + 0.003 * S3 <= 33;
! Silicon content;
0.0225 * P1 + 0.15 * P2 + 0.45 * F1 + 0.42 * F2 + 0.18 * A1 + 0.3 *
A2 + 0.25 * A3 + 0.3 * CB >= 54;
0.0225 * P1 + 0.15 * P2 + 0.45 * F1 + 0.42 * F2 + 0.18 * A1 + 0.3 *
A2 + 0.25 * A3 + 0.3 * CB <= 60;
! Finish good requirements;
P1 + P2 + F1 + F2 + A1 + A2 + A3 + CB + S1 + S2 + S3 = 2000;

```

In words, the general form of this model is:

Minimize cost of raw materials
subject to
(a) Raw material availabilities (rows 2-5)
(b) Quality requirements (rows 6-13)
(c) Finish good requirements (row 14)

It is generally good practice to be consistent and group constraints in this fashion.

For this particular example, when writing the quality constraints, we have exploited the knowledge that the batch size is 2000. For example, 3% of 2000 is 60, 3.5% of 2000 is 70, etc.

When solved, we get the solution:

Optimal solution found at step:		11
Objective value:		59.55629
Variable	Value	Reduced Cost
P1	1474.264	0.0000000
P2	60.00000	0.0000000
F1	0.0000000	0.1035937E-02
F2	22.06205	0.0000000
A1	14.23886	0.0000000
A2	0.0000000	0.2050311E-01
A3	0.0000000	0.1992597E-01
CB	0.0000000	0.3356920E-02
S1	200.0000	0.0000000
S2	29.43496	0.0000000
S3	200.0000	0.0000000
Row	Slack or Surplus	Dual Price
1	59.55629	1.000000
2	20.00000	0.0000000
3	0.0000000	0.1771118E-03
4	170.5650	0.0000000
5	0.0000000	0.5000000E-03
6	0.0000000	-0.1833289
7	10.00000	0.0000000
8	0.0000000	-0.2547314
9	3.000000	0.0000000
10	0.0000000	-0.1045208
11	6.000000	0.0000000
12	0.0000000	-0.9880212E-01
13	6.000000	0.0000000
14	0.0000000	-0.1950311E-01

Notice only 7 of the 11 raw materials were used.

In actual practice, this type of LP was solved on a twice-monthly basis by Pittsburgh Steel. The purchasing agent used the first solution, including the reduced cost and dual prices, as a guide in buying materials. The second solution later in the month was mainly for the metallurgist's benefit in making up a blend from the raw materials actually on hand.

Suppose we can pump oxygen into the furnace. This oxygen combines completely with carbon to produce the gas CO_2 , which escapes. The oxygen will burn off carbon at the rate of 12 pounds of carbon burned off for each 32 pounds of oxygen. Oxygen costs two cents a pound. If you reformulated the problem to include this additional option, would it change the decisions? The oxygen injection option to burn off carbon is clearly uninteresting because, in the current solution, it is the lower bound constraint rather than the upper bound on carbon that is binding. Thus, burning off carbon by itself, even if it could be done at no expense, would increase the total cost of the solution.

10.3 A Blending Problem within a Product Mix Problem

One additional aspect of blending problem formulation will be illustrated with an example in which the batch size is a decision variable. In the previous example, the batch size was specified. In the following example, the amount of product to be blended depends upon how cheaply the product can be

blended. Thus, it appears the blending decision and the batch size decision must be made simultaneously.

This example is suggestive of gasoline blending problems faced in a petroleum refinery. We wish to blend gasoline from three ingredients: butane, heavy naphtha, and catalytic reformat. Four characteristics of the resultant gasoline and its inputs are important: cost, octane number, vapor pressure, and volatility. These characteristics are summarized in the following table:

Feature	Commodity				
	Butane (BUT)	Catalytic Reformat (CAT)	Heavy Naphtha (NAP)	Regular Gasoline (REG)	Premium Gasoline (PRM)
Cost/Unit	7.3	18.2	12.5	-18.4	-22
Octane	120.0	100.0	74.0	$89 \leq \text{oct} \leq 110$	$94 \leq \text{oct} \leq 110$
Vapor Pressure	60.0	2.6	4.1	$8 \leq \text{vp} \leq 11$	$8 \leq \text{vp} \leq 11$
Volatility	105.0	3.0	12.0	$17 \leq \text{vo} \leq 25$	$17 \leq \text{vo} \leq 25$
Availability	1000.0	4000.0	5000.0	$4000 \leq \text{sell} \leq 8000$	$2000 \leq \text{sell} \leq 6000$

The cost per unit for *REG* and *PRM* are listed as negative, meaning we can sell them. That is, a negative cost is a revenue.

The octane rating is a measure of the gasoline's resistance to "knocking" or "pinging". Vapor pressure and volatility are closely related. Vapor pressure is a measure of susceptibility to stalling, particularly on an unusually warm spring day. Volatility is a measure of how easily the engine starts in cold weather.

From the table, we see in this planning period, for example, there are only 1,000 units of butane available. The profit contribution of regular gasoline is \$18.40 per unit *exclusive* of the cost of its ingredients.

A slight simplification assumed in this example is that the interaction between ingredients is linear. For example, if a "fifty/fifty" mixture of *BUT* and *CAT* is made, then its octane will be $0.5 \times 120 + 0.5 \times 100 = 110$ and its volatility will be $0.5 \times 105 + 0.5 \times 3 = 54$. In reality, this linearity is violated slightly, especially with regard to octane rating.

10.3.1 Formulation

The quality constraints require a bit of thought. The fractions of a batch of *REG* gasoline consisting of Butane, Catalytic Reformat, and Heavy Naphtha are *BUT/REG*, *CAT/REG*, and *NAP/REG*, respectively. Thus, if the god of linearity smiles upon us, the octane constraint of the blend for *REG* should be the expression:

$$(BUT/REG) \times 120 + (CAT/REG) \times 100 + (NAP/REG) \times 74 \geq 89.$$

Your expression, however, may be a frown because a ratio of variables like *BUT/REG* is definitely not linear. Multiplying through by *REG*, however, produces the linear constraint:

$$120 BUT + 100 CAT + 74 NAP \geq 89 REG$$

or in standard form:

$$120 BUT + 100 CAT + 74 NAP - 89 REG \geq 0.$$

10.3.2 Representing Two-sided Constraints

All the quality requirements are two sided. That is, they have both an upper limit and a lower limit. The upper limit constraint on octane is clearly:

$$120 \text{ BUT} + 100 \text{ CAT} + 74 \text{ NAP} - 110 \text{ REG} \leq 0.$$

We can write it in equality form by adding an explicit slack:

$$120 \text{ BUT} + 100 \text{ CAT} + 74 \text{ NAP} - 110 \text{ REG} + \text{SOCT} = 0.$$

When $\text{SOCT} = 0$, the upper limit is binding. You can verify that, when $\text{SOCT} = 110 \text{ REG} - 89 \text{ REG} = 21 \text{ REG}$, the lower limit is binding. Thus, a compact way of writing both the upper and lower limits is with the two constraints:

- 1) $120 \text{ BUT} + 100 \text{ CAT} + 74 \text{ NAP} - 110 \text{ REG} + \text{SOCT} = 0$,
- 2) $\text{SOCT} \leq 21 \text{ REG}$.

Notice, even though there may be many ingredients, the second constraint involves only two variables. This is a compact way of representing two-sided constraints.

Similar arguments can be used to develop the vapor and volatility constraints. Finally, a constraint must be appended, which states the whole equals the sum of its parts, specifically:

$$\text{REG} = \text{BUT} + \text{NAP} + \text{CAT}.$$

When all constraints are converted to standard form and the expression for profit contribution is written, we obtain the formulation:

```

MODEL:
MAX = 22 * B_PRM + 18.4 * B_REG - 7.3 * XBUT_PRM - 7.3 * XBUT_REG -
12.5 * XNAP_PRM - 12.5 * XNAP_REG - 18.2 * XCAT_PRM - 18.2 *
XCAT_REG;
! Subject to raw material availabilities;
[RMLIMBUT] XBUT_PRM + XBUT_REG <= 1000;
[RMLIMCAT] XCAT_PRM + XCAT_REG <= 4000;
[RMLIMNAP] XNAP_PRM + XNAP_REG <= 5000;
!For each finished good, batch size computation;
[BDEF_REG] B_REG - XNAP_REG - XCAT_REG - XBUT_REG=0;
[BDEF_PRM] B_PRM - XNAP_PRM - XCAT_PRM - XBUT_PRM=0;
! Batch size limits;
[BLO_REG] B_REG >= 4000;
[BHI_REG] B_REG <= 8000;
[BLO_PRM] B_PRM >= 2000;
[BHI_PRM] B_PRM <= 6000;
! Quality restrictions for each quality;
[QUPREGOC] - 110 * B_REG + SOCT_REG + 74 * XNAP_REG + 100 * XCAT_REG
+ 120 * XBUT_REG = 0;
[QDNREGOC] - 21 * B_REG + SOCT_REG <= 0;
[QUPREGVA] - 11 * B_REG + SVAP_REG + 4.1 * XNAP_REG + 2.6 * XCAT_REG
+ 60 * XBUT_REG = 0;
[QDNREGVA] - 3 * B_REG + SVAP_REG <= 0;
[QUPREGVO] - 25 * B_REG + SVOL_REG + 12 * XNAP_REG + 3 * XCAT_REG +
105 * XBUT_REG = 0;
[QDNREGVO] - 8 * B_REG + SVOL_REG <= 0;

```



```

[QUPPRMOC] - 110 * B_PRM + SOCT_PRM + 74 * XNAP_PRM + 100 * XCAT_PRM
+ 120 * XBUT_PRM = 0;
[QDNPRMOC] - 16 * B_PRM + SOCT_PRM <= 0;
[QUPPRMVA] - 11 * B_PRM + SVAP_PRM + 4.1 * XNAP_PRM + 2.6 * XCAT_PRM
+ 60 * XBUT_PRM = 0;
[QDNPRMVA] - 3 * B_PRM + SVAP_PRM <= 0;
[QUPPRMVO] - 25 * B_PRM + SVOL_PRM + 12 * XNAP_PRM + 3 * XCAT_PRM +
105 * XBUT_PRM = 0;
[QDNPRMVO] - 8 * B_PRM + SVOL_PRM <= 0;
END

```

The following is the same problem, set in a general, set-based blending formulation:

```

MODEL:
  ! General Blending Model (BLEND) in LINGO;
  SETS:
    ! Each raw material has availability & cost/unit;
    RM/ BUT, CAT, NAP/: A, C;
    ! Each f. g. has min & max sellable, profit
    contr./unit and batch size to be determined;
    FG/ REG, PRM/: D, E, P, B;
    ! There are a set of quality measures;
    QM/ OCT, VAP, VOL/;
    ! Each RM & QM combo has a quality level;
    RQ( RM, QM): Q;
    ! For each combo QM, FG there are upper &
    lower limits on quality, slack on quality
    to be determined;
    QF( QM, FG): U, L, S;
    ! Each combination of RM and FG has an amount
    used, to be determined;
    RF( RM, FG): X;
  ENDSETS
  DATA:
    A=1000, 4000, 5000; ! Raw material availabilities;
    C = 7.3, 18.2, 12.5; ! R. M. costs;
    Q = 120, 60, 105, ! Quality parameters...;
        100, 2.6, 3, ! R. M. by quality;
        74, 4.1, 12;
    D = 4000, 2000; ! Min needed of each F.G.;
    E = 8000, 6000; ! Max sellable of each F.G.;
    P = 18.4, 22; ! Selling price of each F.G.;
    U = 110, 110, ! Upper limits on quality;
        11, 11, ! Quality by F.G.;
        25, 25;
    L = 89, 94, ! Lower limits on quality...;
        8, 8, ! Quality by F.G.;
        17, 17;
  ENDDATA

```

```

!-----;
! The model;
! For each raw material, the availabilities;
  @FOR( RM( I):
    [RMLIM] @SUM( FG( K): X( I, K)) < A( I);
  );
  @FOR( FG( K):
!For each finished good, compute batch size;
  [BDEF] B( K) = @SUM( RM( I): X( I, K));
  ! Batch size limits;
    [BLO] B( K) > D( K);
    [BHI] B( K) < E( K);
  ! Quality restrictions for each quality;
  @FOR( QM( J):
[QUP]@SUM( RM(I): Q(I, J) * X(I, K)) + S( J,
  K) = U( J, K) * B( K);
[QDN] S(J, K) < (U(J, K) - L(J, K)) * B(K);
  ); );
!We want to maximize profit contribution;
[PROFIT] MAX = @SUM( FG: P * B)
  - @SUM( RM( I): C( I) * @SUM( FG( K): X( I, K)));
END

```

As with all of our set based models, the data are well separated from the model equations. Thus, when the data change, the user need not be concerned with the model equations when updating the model.

The interesting part of the solution is:

Objective value:		48750.00	
	Variable	Value	Reduced Cost
	B(REG)	4000.000	0.0000000
	B(PRM)	4500.000	0.0000000
	S(OCT, REG)	84000.00	0.0000000
	S(OCT, PRM)	72000.00	0.0000000
	S(VAP, REG)	1350.424	0.0000000
	S(VAP, PRM)	7399.576	0.0000000
	S(VOL, REG)	17500.00	0.0000000
	S(VOL, PRM)	36000.00	0.0000000
	X(BUT, REG)	507.4153	0.0000000
	X(BUT, PRM)	492.5847	0.0000000
	X(CAT, REG)	1409.958	0.0000000
	X(CAT, PRM)	2590.042	0.0000000
	X(NAP, REG)	2082.627	0.0000000
	X(NAP, PRM)	1417.373	0.0000000
	Row	Slack or Surplus	Dual Price
	RMLIM(BUT)	0.0000000	27.05000
	RMLIM(CAT)	0.0000000	6.650000
	RMLIM(NAP)	1500.000	0.0000000
	BDEF(REG)	0.0000000	-22.65000
	BLO(REG)	0.0000000	-1.225000
	BHI(REG)	4000.000	0.0000000
	QUP(REG, OCT)	0.0000000	-0.4750000
	QDN(REG, OCT)	0.0000000	0.4750000

QUP (REG, VAP)	0.0000000	0.0000000
QDN (REG, VAP)	10649.58	0.0000000
QUP (REG, VOL)	0.0000000	0.0000000
QDN (REG, VOL)	14500.00	0.0000000
BDEF (PRM)	0.0000000	-22.65000
BLO (PRM)	2500.000	0.0000000
BHI (PRM)	1500.000	0.0000000
QUP (PRM, OCT)	0.0000000	-0.4750000
QDN (PRM, OCT)	0.0000000	0.4750000
QUP (PRM, VAP)	0.0000000	0.0000000
QDN (PRM, VAP)	6100.424	0.0000000
QUP (PRM, VOL)	0.0000000	0.0000000
QDN (PRM, VOL)	0.0000000	0.0000000
PROFIT	48750.00	1.0000000

The solution suggests that Premium is the more profitable product, so we sell the minimum amount of Regular required and then sell as much Premium as scarce resources, BUT and CAT, allow.

LP blending models have been a standard operating tool in refineries for years. Recently, there have been some instances where these LP models have been replaced by more sophisticated nonlinear models, which more accurately approximate the nonlinearities in the blending process. See Rigby, Lasdon, and Waren (1995), for a discussion of how Texaco does it.

There is a variety of complications as gasoline blending models are made more detailed. For example, in high quality gasoline, the vendor may want the octane to be constant across volatility ranges in the ingredients. The reason is, if you “floor” the accelerator on a non-fuel injected automobile, a shot of raw gas is squirted into the intake. The highly volatile components of the blend will reach the combustion chamber first. If these components have low octane, you will have knocking, even though the “average” octane rating of the gasoline is high. This may be more important in a station selling gas for city driving than in a station on a cross country highway in Kansas where most driving is at a constant speed.

10.4 Proper Choice of Alternate Interpretations of Quality Requirements

Some quality features can be stated according to some measure of either goodness or, alternatively, undesirability. An example is the efficiency of an automobile. It could be stated in miles per gallon or alternatively in gallons per mile. In considering the quality of a blend of ingredients (e.g., the efficiency of a fleet of cars), it is important to identify whether it is the goodness or the badness measure which is additive over the components of the blend. The next example illustrates.

A federal regulation required the average of the miles per gallon computed over all automobiles sold by an automobile company in a specific year be at least 18 miles per gallon.

Let us consider a hypothetical case for the Ford Motor Company. Assume Ford sold only the four car types: Mark V, Ford, Granada, and Fiesta. Various parameters of these cars are listed below:

Car	Miles per Gallon	Marginal Prod. Cost	Selling Price
Fiesta	30	13,500	14,000
Granada	18	14,100	15,700
Ford	16	14,500	15,300
Mark V	14	15,700	20,000

There is some flexibility in the production facilities, so capacities may apply to pairs of car types. These limitations are:

Yearly Capacity in Units	Car Types Limited
250,000	Fiestas
2,000,000	Granadas plus Fords
1,500,000	Fords plus Mark V's

There is a sale capacity limit of 3,000,000 on the total of all cars sold. How many of each car type should Ford plan to sell?

Interpreting the mileage constraint literally results in the following formulation:

$$\begin{aligned}
 \text{MAX} &= 500 \cdot \text{FIESTA} + 1600 \cdot \text{GRANADA} + 4300 \cdot \text{MARKV} + 800 \cdot \text{FORD}; \\
 12 \cdot \text{FIESTA} &\quad - 4 \cdot \text{MARKV} - 2 \cdot \text{FORD} &>= 0; \\
 \text{FIESTA} & &<= 250; \\
 &\quad \text{GRANADA} &+ \text{FORD} <= 2000; \\
 &\quad \quad \text{MARKV} &+ \text{FORD} <= 1500; \\
 \text{FIESTA} &+ \text{GRANADA} &+ \text{MARKV} &+ \text{FORD} <= 3000;
 \end{aligned}$$

Automobiles and dollars are measured in 1000s. Note row 2 is equivalent to:

$$\frac{30 \text{ Fiesta} + 18 \text{ Granada} + 16 \text{ Ford} + 14 \text{ Mark V}}{\text{Fiesta} + \text{Granada} + \text{Ford} + \text{Mark V}} \geq 18.$$

The solution is:

Optimal solution found at step:		1
Objective value:		6550000.
Variable	Value	Reduced Cost
FIESTA	250.0000	0.0000000
GRANADA	2000.000	0.0000000
MARKV	750.0000	0.0000000
FORD	0.0000000	2950.000
Row	Slack or Surplus	Dual Price
1	6550000.	1.000000
2	0.0000000	-1075.000
3	0.0000000	13400.00
4	0.0000000	1600.000
5	750.0000	0.0000000
6	0.0000000	0.0000000

Let's look more closely at this solution. Suppose each car is driven the same number of miles per year regardless of type. An interesting question is whether the ratio of the total miles driven by the above fleet divided by the number of gallons of gasoline used is at least equal to 18. Without loss, suppose each car is driven one mile. The gasoline used by a car driven one mile is 1/(miles per gallon). Thus, if all the cars are driven the same distance, then the ratio of miles to gallons of fuel of the above fleet is $(250 + 2000 + 750) / [(250/30) + (2000/18) + (750/14)] = 17.3$ miles per gallon—which is considerably below the mpg we thought we were getting.

The first formulation is equivalent to allotting each automobile the same number of gallons and each automobile then being driven until it exhausts its allotment. Thus, the 18 mpg average is attained by having less efficient cars drive fewer miles. A more sensible way of phrasing things is in terms of gallons per mile. In this case, the mileage constraint is written:

$$\frac{Fiesta/30 + Granada/18 + Ford/16 + MarkV/14}{Fiesta + Granada + Ford + MarkV} \leq 1/18$$

Converted to standard form this becomes:

$$-0.022222222 * FIESTA + 0.0069444444 * FORD + 0.015873016 * MARKV = 0;$$

When this problem is solved with this constraint, we get the solution:

Optimal solution found at step:		0
Objective value:		4830000.
Variable	Value	Reduced Cost
FIESTA	250.0000	0.0000000
FORD	0.0000000	2681.250
MARKV	350.0000	0.0000000
GRANADA	2000.000	0.0000000

Notice the profit contribution drops noticeably under this second interpretation. The federal regulations could very easily be interpreted to be consistent with the first formulation. Automotive companies, however, wisely implemented the second way of computing fleet mileage rather than leave themselves open to later criticism of having implemented what Uncle Sam said rather than what he meant.

For reference, in 1998, the U.S. "light truck" (so-called sport utility vehicles) fleet mileage requirement was 20.7 miles per gallon, and the passenger car fleet requirement was 27.5 miles per gallon. For each tenth of a mile per gallon that a fleet falls short of the requirement, the U.S. Federal government sets a fine of \$5 per vehicle. The requirements are based on a "model year" basis. This gives a car manufacturer some flexibility if it looks like it might miss the target in a given year. For example, the manufacturer could "stop production" of a vehicle that has poor mileage, such as the big Chevy Suburban, and declare that all subsequent copies sold belong to the next model year. This may achieve the target in the current model year, but postpone the problem to the next model year.

10.5 How to Compute Blended Quality

The general conclusion is one should think carefully when one needs to compute an average performance measure for some blend or collection of things. There are at least three ways of computing averages or means when one has N observations, x_1, x_2, \dots, x_N :

$$\text{Arithmetic: } (x_1 + x_2 + \dots + x_N)/N$$

$$\text{Geometric: } (x_1 \times x_2 \times \dots \times x_N)^{(1/N)}$$

$$\text{Harmonic: } 1/[(1/x_1 + 1/x_2 + \dots + 1/x_N)/N]$$

The arithmetic mean is appropriate for computing the mean return of the assets in a portfolio. If, however, we are interested in the average growth of a portfolio over time, we would probably want to use the geometric mean of the yearly growths rather than the arithmetic average. Consider, for example, an investment that has a growth factor of 1.5 in the first year and 0.67 in the second year (e.g., a rate of return of 50% in the first year and -33% in the second year). Most people would *not*

consider the average growth to be $(1.5 + 0.67)/2 = 1.085$. The harmonic mean tends to be appropriate when computing an average rate of something, as in our car fleet example above.

A quality measure for which the harmonic mean is usually appropriate is density. For some products, such as food and feed, one may have available different ingredients each with different densities and desire a blend of these products with a specific density. Density is usually measured in weight per volume (e.g., grams per cubic centimeter). If the decision variables are measured in weight units rather than volume units, then the harmonic mean is appropriate.

10.5.1 Example

We have two ingredients, one with a density of 0.7 g/cc and the other with a density of 0.9 g/cc. If we mix together one gram of each, what is the density of the mix? Clearly, the mix has a weight of 2 grams. Its volume in cc's is $1/0.7 + 1/0.9$. Thus, its density is $2/(1/0.7 + 1/0.9) = 0.7875$ g/cc. This is less than the 0.8 we would predict if we took the arithmetic average. If we define:

X_i = grams of ingredient i in the mix,
 t = target lower limit on density desired.

Then, we can write the density constraint for our little example as:

$$(X_1 + X_2)/(X_1/0.7 + X_2/0.9) = t$$

or

$$(X_1 + X_2)/t = X_1/0.7 + X_2/0.9$$

or

$$X_1/0.7 + X_2/0.9 = (X_1 + X_2)/t,$$

(i.e., a harmonic mean constraint).

10.5.2 Generalized Mean

One can generalize the idea just discussed by introducing a transformation $f(q)$. The interpretation is that the function $f()$ "linearizes" the quality. The basic idea is that many of the quality measures used in practice were chosen somewhat arbitrarily (e.g., why is the freezing point of water 32 degrees on the Fahrenheit scale?). So, even though a standardly used quality measure does not "blend linearly", perhaps we can find a transformation that does. Such linearizations are common in industry. Some examples follow:

1. Rigby, Lasdon, and Waren (1995) use this idea when calculating the Reid vapor pressure of a blended gasoline at Texaco. If r_i is the Reid vapor pressure of component i of the blend, they use the transformation:

$$f(r_i) = r_i^{1.25}$$

For example, if component 1 has a vapor pressure of 80, component 2 has a vapor pressure of 100, x_i is the amount used of component i , and we want a blend with a vapor pressure of at least 90, the constraint could be written:

$$80^{1.25} \times x_1 + 100^{1.25} \times x_2 \geq 90^{1.25} \times (x_1 + x_2),$$

or

$$239.26 \times x_1 + 316.23 \times x_2 \geq 277.21 (x_1 + x_2).$$

2. The *flashpoint* of a chemical is the lowest temperature at which it will catch fire. Typical jet fuel has a flashpoint of around 100 degrees F. Typical heating oil has a flashpoint of at least 130 degrees F. The jet fuel used in the supersonic SR-71 jet aircraft had a flashpoint of several hundred degrees F. If p_i is the flashpoint of component i , then the transformation:

$$f(p_i) = 10^{42} (p_i + 460)^{-14.286}$$

will approximately linearize the flashpoint.

For example, if component 1 has a flashpoint of 100, component 2 has a flashpoint of 140, x_i is the amount used of component i , and we want a blend with a flashpoint of at least 130, the constraint would be written:

$$10^{42} (100 + 460)^{-14.286} \times x_1 + 10^{42} (140 + 460)^{-14.286} \times x_2 \leq 10^{42} (130 + 460)^{-14.286} \times (x_1 + x_2),$$

or

$$548.76 \times x_1 + 204.8 x_2 \leq 260 (x_1 + x_2).$$

3. The American Petroleum Institute likes to measure the lightness of a material in “API gravity”, see Dantzig and Thapa (1997). API gravity does not blend linearly. However, the specific gravity, defined by:

$$sg = 141.5 / (API \text{ gravity} + 131.5)$$

does blend linearly. Note, the specific gravity of a material is the weight in grams of one cubic centimeter of material. Water has an API gravity of 10.

4. The *viscosity* of a liquid is a measure, in units of centistokes, of the time it takes a standard volume of liquid, at 122 degrees Fahrenheit, to flow through a hole of a certain diameter. The higher the viscosity, the less easily the liquid flows. If v_i is the viscosity of component i , then the transformation:

$$f(v_i) = \ln(\ln(v_i + .08))$$

will approximately linearize the viscosity.

For example, if component 1 has a viscosity of 5, component 2 has a viscosity of 25, x_i is the amount used of component i , and we want a blend with a viscosity of at most 20, the constraint would be written:

$$\ln(\ln(5 + .08)) \times x_1 + \ln(\ln(25 + .08)) \times x_2 \leq \ln(\ln(20 + .08)) \times (x_1 + x_2),$$

or

$$.4857 x_1 + 1.17 x_2 \leq 1.0985(x_1 + x_2).$$

5. In the transmissivity of light through a glass fiber of length x_i , or the financial growth of an investment over a period of length x_i , or in the probability of no failures in a number of trials x_i , one may have constraints of the form: $a_1^{x_1} a_2^{x_2} \dots a_n^{x_n} \geq a_0$. This can be linearized by taking logarithms (e.g., $\ln(a_1) * x_1 + \ln(a_2) * x_2 + \dots \ln(a_n) * x_n \geq \ln(a_0)$).

For example, if we expect stocks to have a long term growth rate of 10% per year, we expect less risky bonds to have a long term growth rate of 6% per year, we want an

overall growth of 40% over five years, and x_1 and x_2 are the number of years we invest in stocks and bonds respectively over a five year period, then we want the constraint:

$$(1.10)^{x_1}(1.06)^{x_2} \geq 1.40.$$

Linearizing, this becomes:

$$\begin{aligned} \ln(1.10)x_1 + \ln(1.06)x_2 &\geq \ln(1.40), \text{ or} \\ .09531x_1 + .05827x_2 &\geq .3364, \\ x_1 + x_2 &= 5. \end{aligned}$$

The preceding examples apply the transformation to each quality individually. One could extend the idea even further by allowing a “matrix” transformation to several qualities together.

10.6 Interpretation of Dual Prices for Blending Constraints

The dual price for a blending constraint usually requires a slight reinterpretation in order to be useful. As an example, consider the octane constraint of the gasoline blending problem:

$$-94 \text{ RG} + 120 \text{ BT} + 74 \text{ NAP} + 100 \text{ CR} \geq 0.$$

The dual price of this constraint is the increase in profit if the right-hand side of this constraint is changed from 0 to 1. Unfortunately, this is not a change we would ordinarily consider. More typical changes that might be entertained would be changing the octane rating from 94 to either 93 or 95. A very approximate rule for estimating the effect of changing the coefficient in row i of variable RG is to compute the product of the dual price in row i and the value of variable RG . For variable RG and the octane constraint, this value is $7270.30 \times (-0.204298) = -1485.31$. This suggests, if the octane requirement is reduced to 93 (or increased to 95) from 94, the total profit will increase by about 1485 to \$44,814 (or decrease by about 1485 to \$41,843). For small changes, this approximation will generally understate the true profit after the change. When the LP is actually re-solved with an octane requirement of 93 (or 95), the actual profit contribution changes to \$44,825 (or \$43,200).

This approximation can be summarized generally as follows:

If we wish to change a certain quality requirement of blend by a small amount δ , the effect on profit of this change is approximately of the magnitude $\delta \times (\text{dual price of the constraint}) \times (\text{batch size})$. For small changes, the approximation tends to understate profit after the change. For large changes, the approximation may err in either direction.

10.7 Fractional or Hyperbolic Programming

In blending problems, we have seen ratio constraints of the form:

$$\frac{\sum_j q_j X_j}{\sum_j X_j} \geq q_0$$

can be converted to linear form, by rewriting:

$$\sum_j q_j X_j \geq q_0 \sum X_j \quad \text{or} \quad \sum (q_j - q_0) x_j \geq 0$$

Can we handle a similar feature in the objective? That is, can a problem of the following form be converted to linear form?

$$(1) \text{ Maximize } \frac{u_o + \sum_j u_j X_j}{v_o + \sum_j v_j X_j}$$

$$(2) \text{ subject to: } \sum_j a_{ij} X_j = b_i$$

The a_{ij} , u_o , u_j , v_o , and v_j are given constants. For example, we might wish to maximize the fraction of protein in a blend subject to constraints on availability of materials and other quality specifications.

We can make it linear with the following transformations:

Define:

$$r = 1/(v_o + \sum_j v_j X_j)$$

and

$$y_j = X_j r$$

We assume $r > 0$.

Then our objective is:

$$(1') \text{ Maximize } u_o r + \sum_j v_j y_j$$

subject to:

$$r = 1/(v_o + \sum_j v_j X_j)$$

$$(1.1') \quad r v_o + \sum_j v_j y_j = 1$$

Any other constraint i of the form:

$$\sum_j a_{ij} X_j = b_i$$

can be written as:

$$\sum_j a_{ij} X_j r = b_i r$$

or

$$(2') \quad \sum_j a_{ij} y_j - b_i r = 0$$

10.8 Multi-Level Blending: Pooling Problems

A complicating factor in some blending problems is that not all raw ingredients can be stored separately. Such a situation can arise in a number of ways. Two ingredients may be produced at the same location, but for economic reasons, are transported together (e.g., in one tank car or via one pipeline). Another possibility is two ingredients are delivered separately, but only a single holding facility is available at the blending site. In general, many facilities that blend ingredients have only a modest number of storage facilities. For example, a grain storage facility may have only a half dozen bins. A petroleum refinery may have only a half dozen tanks. If there are more than a half dozen different sources of raw materials, then not all raw materials can be stored separately. In the petroleum industry, this leads to what is called a pooling problem.

This pooling of raw materials within a blending problem leads to a nonlinear program. The pooling problem discussed here is taken from Haverly (1978). A , B , and C are ingredients containing 3%, 1%, and 2% sulfur as an impurity, respectively. These chemicals are to be blended to provide two

output products, X and Y , which must meet sulfur content upper limits of 2.5% and 1.5%, respectively. At the given prices of \$9 per unit of X and \$15 per unit of Y , customers will buy all of X and Y produced up to a maximum of 100 units of X and 200 units of Y . The costs per unit for ingredients A , B , and C are \$6, \$16, and \$10, respectively. The problem is to operate the process in order to maximize profit.

A complicating factor in this blending process is the fact that products A and B must be stored in the same tank, or “pool”. So, until the amounts of A and B are determined, the pool sulfur content is unknown. Figure 10.1 illustrates. However, it is the pool sulfur content together with the amounts of pool material and of chemical C used in blending X and Y that determine the X and Y sulfur contents. The sulfur constraints on X and Y affect the amounts of A and B needed, and it is this “circularity” that causes a nonlinearity.

Figure 10.1 A Pooling Problem

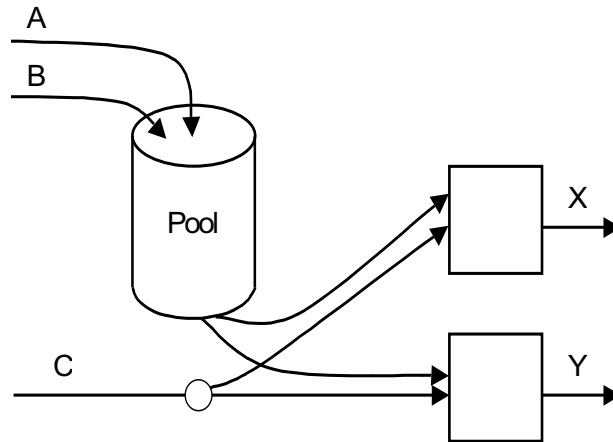

The constraint equations defining this system involve material balances and sulfur constraints for the output products. Consider the material balance equations first.

We have the following mass balance for the pool, assuming all of the pool material is to be used up:

$$\text{Amount } A + \text{Amount } B = \text{Pool to } X + \text{Pool to } Y.$$

For the output products, the balance equations are:

$$\text{Pool to } X + C \text{ to } X = \text{Amount } X$$

and:

$$\text{Pool to } Y + C \text{ to } Y = \text{Amount } Y.$$

For the total amount of C , the equation is:

$$C \text{ to } X + C \text{ to } Y = \text{Amount } C.$$

Introducing the pool sulfur percent, Pool S , as a new variable, makes it easy to write the X and Y sulfur constraints. If we let Pool S have a value between 0 and 100 and express all other percentages on the same scale, these constraints are:

$$\begin{aligned} \text{Pool } S \times \text{Pool to } X + 2 \times C \text{ to } X &\leq 2.5 \times \text{Amount } X \\ \text{Pool } S \times \text{Pool to } Y + 2 \times C \text{ to } Y &\leq 1.5 \times \text{Amount } Y \end{aligned}$$

The left-hand side of each inequality represents the actual sulfur content of the appropriate product and the right-hand side is the maximum amount of sulfur permitted in that product. The pool sulfur balance equation is:

$$3 \times \text{Amount } A + 1 \text{ Amount } B = \text{Pool } S \times (\text{Amount } A + \text{Amount } B).$$

This defines Pool S as the amount of sulfur in the pool divided by the total amount of material in the pool.

As mentioned earlier, product demand sets upper bounds on production as:

$$\begin{aligned} \text{Amount } X &\leq 100 \\ \text{Amount } Y &\leq 200 \end{aligned}$$

and physical considerations restrict all variables to be nonnegative quantities. Clearly, the pool sulfur can never be less than 1% or more than 3%. Thus:

$$1 \leq \text{Pool } S \leq 3.$$

Finally, the profit function must be formulated. If Cost A , Cost B , Cost C , Cost X , and Cost Y are the appropriate cost coefficients, the profit can be written as:

$$\begin{aligned} &\text{Cost } X \times \text{Amount } X + \text{Cost } Y \times \text{Amount } Y - \text{Cost } A \times \text{Amount } A \\ &- \text{Cost } B \times \text{Amount } B - \text{Cost } C \times \text{Amount } C \end{aligned}$$

A LINGO formulation follows:

```

MODEL:
  COSTA = 6;
  COSTB = 16;
  COSTC = 10;
  COSTX = 9;
  COSTY = 15;
  MAX = COSTX * AMOUNTX + COSTY * AMOUNTY - COSTA * AMOUNTA - COSTB *
AMOUNTB - COSTC * AMOUNTC;
  ! Sources = uses for the pool;
  AMOUNTA + AMOUNTB = POOLTOX + POOLTOY;
  ! Sources for final products;
  POOLTOX + CTOX = AMOUNTX;
  POOLTOY + CTOY = AMOUNTY;
  ! Uses of C;
  AMOUNTC = CTOX + CTOY;
  ! Blending constraints for final products;
  POOLS * POOLTOX + 2 * CTOX <= 2.5 * AMOUNTX;
  POOLS * POOLTOY + 2 * CTOY <= 1.5 * AMOUNTY;
  ! Blending constraint for the pool product;
  3*AMOUNTA + AMOUNTB=POOLS*(AMOUNTA + AMOUNTB);
  ! Demand upper limits;

```

```

    AMOUNTX <= 100;
    AMOUNTY <= 200;
END

```

This problem is tricky in that it has (as we shall see) several local optima. LINGO, left to its own devices, finds the following solution:

```

Optimal solution found at step:      16
Objective value:                    400.0000
Variable      Value      Reduced Cost
COSTA         6.000000      0.0000000
COSTB        16.000000      0.0000000
COSTC        10.000000      0.0000000
COSTX         9.000000      0.0000000
COSTY        15.000000      0.0000000
AMOUNTX       0.0000000      0.0000000
AMOUNTY      200.000000      0.0000000
AMOUNTA       0.0000000      2.0000003
AMOUNTB       100.000000      0.0000000
AMOUNTC      100.000000      0.0000000
POOLTOX       0.0000000      4.0000026
POOLTOY      100.000000      0.0000000
CTOX          0.0000000      0.0000000
CTOY         100.000000      0.0000000
POOLS        0.99999932      0.0000000

```

Examination of the solution shows the optimal operation produces only product *Y* using equal amounts of *B* and *C*. The cost per unit of output is $\$(16 + 10) / 2 = \13 and the sale price is \$15, giving a profit of \$2 per unit. Since all 200 units are produced and sold, the profit is \$400.

Nonlinear problems, such as this pooling model, have the curious feature that the solution you get may depend upon where the solver starts its solution search. You can set the starting point by inserting an "INIT" initialization section in your model such as the following:

```

INIT:
    AMOUNTX = 0
    AMOUNTY = 0
    AMOUNTA = 0
    AMOUNTB = 0
    AMOUNTC = 0
    POOLTOX = 0
    POOLTOY = 0
    CTOX = 0
    CTOY = 0
    POOLS = 3
ENDINIT

```

The INIT section allows you to provide the solver with an initial guess at the solution. Starting at the point provided in the INIT section, LINGO now finds the solution:

```

Optimal solution found at step:      4
Objective value:                    100.0000
Variable      Value      Reduced Cost
AMOUNTX      100.0000      0.0000000
AMOUNTY       0.0000000      0.0000000

```

AMOUNTA	50.00000	0.0000000
AMOUNTB	0.0000000	2.0000005
AMOUNTC	50.00000	0.0000000
POOLTOX	50.00000	0.0000000
POOLTOY	0.0000000	6.0000000
CTOX	50.00000	0.0000000
CTOY	0.0000000	0.0000000
POOLS	3.000000	0.0000000
COSTA	6.000000	0.0000000
COSTB	16.00000	0.0000000
COSTC	10.00000	0.0000000
COSTX	9.000000	0.0000000
COSTY	15.00000	0.0000000

In this solution, only product X is produced and sold. It is made using an equal blend of chemicals A and C . The net cost of production is \$8 per unit, yielding a profit of \$1 per unit of X sold. Since only 100 units are called for, the final profit is \$100. This solution is locally optimal. That is, small changes from this operating point reduce the profit. There are no feasible operating conditions close to this one that yield a better solution.

Our earlier solution, yielding a profit of \$400, is also a local optimum. However, there is no other feasible point with a larger profit, so we call the \$400 solution a global optimum. The reader is invited to find other local optima, for example, by increasing the use of A and decreasing B and C .

Generally speaking, an initial guess should not set variable values to zero. Since zero multiplied by any quantity is still zero, such values can lead to unusual behavior of the optimization algorithm. For example, if we take our previous initial guess, except set $POOLS = 2$, the solver gets stuck at this point and gives the solution:

Optimal solution found at step:		1
Objective value:		0.0000000E+00
Variable	Value	Reduced Cost
AMOUNTX	0.0000000	0.0000000
AMOUNTY	0.0000000	0.0000000
AMOUNTA	0.0000000	6.0000000
AMOUNTB	0.0000000	16.0000000
AMOUNTC	0.0000000	0.0000000
POOLTOX	0.0000000	-10.0000000
POOLTOY	0.0000000	-10.0000000
CTOX	0.0000000	0.0000000
CTOY	0.0000000	0.0000000
POOLS	2.0000000	0.0000000
COSTA	6.0000000	0.0000000
COSTB	16.0000000	0.0000000
COSTC	10.0000000	0.0000000
COSTX	9.0000000	0.0000000
COSTY	15.0000000	0.0000000

As this output shows, LINGO finds the starting point to be optimal. Actually, this point is not even a local optimum, but rather a stationary point (i.e., very small changes do not provide any significant improvement, within the tolerances used in the algorithm, in the objective). The point satisfies the so-called first-order necessary conditions for an optimum. If, however, the starting point is perturbed by some small amount, the solver should find an actual local optimum and perhaps the

global one. In fact, setting all variables previously at zero to 0.1 does lead to the global maximum solution with profit of \$400.

For this problem, all solutions obtained have the property that many constraints are active. In other words, they hold as equalities. Of course, the five equality constraints (rows 2 through 5 and row 8) are always active. In addition, in the globally optimal solution, the sulfur content of Y is at its upper limit, and six variables are either at lower or upper limits ($POOLS$, $CTOX$, $POOLTOX$, $AMOUNTA$, $AMOUNTY$, and $AMOUNTX$). Hence, there are twelve active constraints, but only ten variables. When there are at least as many active constraints as there are variables, this is called a vertex solution. In linear programming, any LP having an optimal solution has a vertex solution. This is not true in NLP, but vertex optima are not uncommon and seem to occur frequently in models involving blending and processing.

When there are more active constraints than variables, the vertex is called degenerate. In the global solution to this problem, there are two “extra” active constraints. One could be removed by dropping the upper and lower limits on $POOLS$. These are redundant because they are implied by constraint 8 and the nonnegativity of the variables. The lower limits on $AMOUNTX$ and $AMOUNTY$ could also be dropped, since they are implied by rows 3 and 4 and the lower limits on $CTOX$, $CTOY$, $POOLTOX$, and $POOLTOY$. Doing this would lead to the same vertex solution, but with exactly as many active constraints as variables. Some other constraints are redundant too. The reader is invited to find them.

10.9 Problems

- The Exxoff Company must decide upon the blends to be used for this week’s gasoline production. Two gasoline products must be blended and their characteristics are listed below:

Gasoline	Vapor Pressure	Octane Number	Selling Price (in \$/barrel)
Lo-lead	≤ 7	≥ 80	\$ 9.80
Premium	≤ 6	≥ 100	\$12.00

The characteristics of the components from which the gasoline can be blended are shown below:

Component	Vapor Pressure	Octane Number	Available this Week (in barrels)
Cat-Cracked Gas	8	83	2700
Isopentane	20	109	1350
Straight Gas	4	74	4100

The vapor pressure and octane number of a blend is simply the weighted average of the corresponding characteristics of its components. Components not used can be sold to “independents” for \$9 per barrel.

- What are the decision variables?
- Give the LP formulation.
- How much Premium should be blended?

2. The Blendex Oil Company blends a regular and a premium product from two ingredients, Heptane and Octane. Each liter of regular is composed of exactly 50% Heptane and 50% Octane. Each liter of premium is composed of exactly 40% Heptane and 60% Octane. During this planning period, there are exactly 200,000 liters of Heptane and 310,000 liters of Octane available. The profit contributions per liter of the regular and premium product this period are \$0.03 and \$0.04 per liter respectively.
- Formulate the problem of determining the amounts of the regular and premium products to produce as an LP.
 - Determine the optimal amounts to produce without the use of a computer.
3. Hackensack Blended Whiskey Company imports three grades of whiskey: Prime, Choice, and Premium. These unblended grades can be used to make up the following two brands of whiskey with associated characteristics:

Brand	Specifications	Selling price per liter
Scottish Club	Not less than 60% Prime. Not more than 20% Premium.	\$6.80
Johnny Gold	Not more than 60% Premium. Not less than 15% Prime.	\$5.70

The costs and availabilities of the three raw whiskeys are:

Whiskey	Available This Week (Number of Liters)	Cost per Liter
Prime	2,000	\$7.00
Choice	2,500	\$5.00
Premium	1,200	\$4.00

Hackensack wishes to maximize this week's profit contribution and feels it can use linear programming to do so. How much should be made of each of the two brands? How should the three raw whiskeys be blended into each of the two brands?

4. The Sebastopol Refinery processes two different kinds of crude oil, Venezuelan and Saudi, to produce two general classes of products, Light and Heavy. Either crude oil can be processed by either of two modes of processing, Short or Regular. The processing cost and amounts of Heavy and Light produced depend upon the mode of processing used and the type of crude oil used. Costs vary, both across crude oils and across processing modes. The relevant characteristics are summarized in the table below. For example, the short process converts each unit of Venezuelan crude to 0.45 units of Light product, 0.52 units of Heavy product, and 0.03 units of waste.

	Short Process		Regular Process	
	Venezuela	Saud	Venezuela	Saud
Light product fraction	0.45	0.60	0.49	0.68
Heavy product fraction	0.52	0.36	0.50	0.32
Unusable product fraction	0.03	0.04	0.01	0.00

Saudi crude costs \$20 per unit, whereas Venezuelan crude is only \$19 per unit. The short process costs \$2.50 per unit processed, while the regular process costs \$2.10 per unit. Sebastopol can process 10,000 units of crude per week at the regular rate. When the refinery is running the Short process for the full week, it can process 13,000 units per week.

The refinery may run any combination of short and regular processes in a given week.

The respective market values of Light and Heavy products are \$27 and \$25 per unit. Formulate the problem of deciding how much of which crudes to buy and which processes to run as an LP. What are the optimal purchasing and operating decisions?

5. There has been a lot of soul searching recently at your company, the Beansoul Coal Company (BCC). Some of its better coal mines have been exhausted and it is having more difficulty selling its coal from remaining mines. One of BCC's most important customers is the electrical utility, Power to the People Company (PPC). BCC sells coal from its best mine, the Becky mine, to PPC. The Becky mine is currently running at capacity, selling all its 5000 tons/day of output to PPC. Delivered to PPC, the Becky coal costs BCC \$81/ton and PPC pays BCC \$86/ton. BCC has four other mines, but you have been unable to get PPC to buy coal from these mines. PPC says that coal from these mines does not satisfy its quality requirements. Upon pressing PPC for details, it has agreed it would consider buying a mix of coal as long as it satisfies the following quality requirements: sulfur $\leq 0.6\%$; ash $\leq 5.9\%$; BTU ≥ 13000 per ton; and moisture $\leq 7\%$. You note your Becky mine satisfies this in that its quality according to the above four measures is: 0.57%, 5.56%, 13029 BTU, and 6.2%. Your four other mines have the following characteristics:

Mine	BTU Per Ton	Sulfur Percent	Ash Percent	Moisture Percent	Cost Per Ton
					Delivered to PPC
Lex	14,201	0.88	6.76	5.1	73
Casper	10,630	0.11	4.36	4.6	90
Donora	13,200	0.71	6.66	7.6	74
Rocky	11,990	0.39	4.41	4.5	89

The daily capacities of your Lex, Casper, Donora, and Rocky mines are 4000, 3500, 3000, and 7000 tons respectively. PPC uses an average of about 13,000 tons per day.

BCC's director of sales was ecstatic upon hearing of your conversation with PPC. His response was "Great! Now, we will be able sell PPC all of the 13,000 tons per day it needs". Your stock with BCC's newly appointed director of productivity is similarly high. Her reaction to your discussion with PCC was: "Let's see, right now we are making a profit contribution of only \$5/ton of coal sold to PPC. I have figured out we can make a profit contribution of \$7/ton if we can sell them a mix. Wow! You are an ingenious negotiator!" What do you recommend to BCC?

6. The McClendon Company manufactures two products, bird food and dog food. The company has two departments, blending and packaging. The requirements in each department for manufacturing a ton of either product are as follows:

	Time per Unit in Tons	
	Blending	Packaging
Bird food	0.25	0.10
Dog food	0.15	0.30

Each department has 8 hours available per day.

Dog food is made from the three ingredients: meat, fishmeal, and cereal. Bird food is made from the three ingredients: seeds, ground stones, and cereal. Descriptions of these five materials are as follows.

Descriptions of Materials in Percents					
	Protein	Carbohydrates	Trace Minerals	Abrasives	Cost (in \$/ton)
Meat	12	10	1	0	600
Fishmeal	20	8	2	2	900
Cereal	3	30	0	0	200
Seeds	10	10	2	1	700
Stones	0	0	3	100	100

The composition requirements of the two products are as follows:

Composition Requirements of the Products in Percents					
	Protein	Carbohydrates	Trace Minerals	Abrasive	Seeds
Bird food	5	18	1	2	10
Dog food	11	15	1	0	0

Bird food sells for \$750 per ton while dog food sells for \$980 per ton. What should be the composition of bird food and dog food and how much of each should be manufactured each day?

7. Recent federal regulations strongly encourage the assignment of students to schools in a city, so the racial composition of any school approximates the racial composition of the entire city. Consider the case of the Greenville city schools. The city can be considered as composed of five areas with the following characteristics:

Area	Fraction Minority	Number of students
1	0.20	1,200
2	0.10	900
3	0.85	1,700
4	0.60	2,000
5	0.90	2,500

The ruling handed down for Greenville is that a school can have neither more than 75 percent nor less than 30 percent minority enrollment. There are three schools in Greenville with the following capacities:

School	Capacity
Bond	3,900
Pocahontas	3,100
Pierron	2,100

The objective is to design an assignment of students to schools, so as to stay within the capacity of each school and satisfy the composition constraints while minimizing the distance traveled by students. The distances in kilometers between areas and schools are:

School	Area				
	1	2	3	4	5
Bond	2.7	1.4	2.4	1.1	0.5
Pocahontas	0.5	0.7	2.9	0.8	1.9
Pierron	1.6	2.0	0.1	1.3	2.2

There is an additional condition that no student can be transported more than 2.6 kilometers. Find the number of students that should be assigned to each school from each area. Assume any group of students from an area has the same ethnic mix as the whole area.

8. A farmer is raising pigs for market and wishes to determine the quantity of the available types of feed that should be given to each pig to meet certain nutritional requirements at minimum cost. The units of each type of basic nutritional ingredient contained in a pound of each feed type is given in the following table along with the daily nutritional requirement and feed costs.

Nutritional Ingredient	Pound of Corn	Pound of Tankage	Pound of Alfalfa	Units Required per day
Carbohydrates	9	2	4	20
Proteins	3	8	6	18
Vitamins	1	2	6	15
Cost (cents)/lb.	7	6	5	

9. Rico-AG is a German fertilizer company, which has just received a contract to supply 10,000 tons of 3-12-12 fertilizer. The guaranteed composition of this fertilizer is (by weight) at least 3% nitrogen, 12% phosphorous, and 12% potash. This fertilizer can be mixed from any combination of the raw materials described in the table below.

Raw Material	% Nitrogen	% Phosphorous	% Potash	Current World Price/Ton
AN	50	0	0	190 Dm
SP	1	40	5	180 Dm
CP	2	4	35	196 Dm
BG	1	15	17	215 Dm

Rico-AG has in stock 500 tons of SP that was bought earlier for 220 Dm/ton. Rico-AG has a long-term agreement with Fledermausguano, S.A. This agreement allows it to buy already mixed 3-12-12 at 195 Dm/ton.

- Formulate a model for Rico-AG that will allow it to decide how much to buy and how to mix. State what assumptions you make with regard to goods in inventory.
- Can you conclude in advance that no CP and BG will be used because they cost more than 195 Dm/ton?

10. The Albers Milling Company buys corn and wheat and then grinds and blends them into two final products, Fast-Gro and Quick-Gro. Fast-Gro is required to have at least 2.5% protein while Quick-Gro must have at least 3.2% protein. Corn contains 1.9% protein while wheat contains 3.8% protein. The firm can do the buying and blending at either the Albers (*A*) plant or the Bartelso (*B*) plant. The blended products must then be shipped to the firm's two warehouse outlets, one at Carlyle (*C*) and the other at Damiansville (*D*). Current costs per bushel at the two plants are:

	A	B
Corn	10.0	14.0
Wheat	12.0	11.0

Transportation costs per bushel between the plants and warehouses are:

Fast-Gro:		To		Quik-Gro:		To	
		C	D			C	D
From	A	1.00	2.00	From	A	3.00	3.50
	B	3.00	0.75		B	4.00	1.90

The firm must satisfy the following demands in bushels at the warehouse outlets:

Warehouse	Product	
	Fast-Gro	Quik-Gro
C	1,000	3,000
D	4,000	6,000

Formulate an LP useful in determining the purchasing, blending, and shipping decisions.

11. A high quality wine is typically identified by three attributes: (a) its vintage, (b) its variety, and (c) its region. For example, the Optima Winery of Santa Rosa, California produced a wine with a label that stated: 1984, Cabernet Sauvignon, Sonoma County. The wine in the bottle may be a blend of wines, not all of which need be of the vintage, variety, and region specified on the label. In this case, the state of California and the U.S. Department of Alcohol, Tobacco, and Firearms strictly enforce the following limits. To receive the label 1984, Cabernet Sauvignon, Sonoma County, at least 95% of the contents must be of 1984 vintage, at least 75% of the contents must be Cabernet Sauvignon, and at least 85% must be from Sonoma County. How small might be the fraction of the wine in the bottle that is of 1984 vintage *and* of the Cabernet Sauvignon variety *and* from grapes grown in Sonoma County?
12. Rogers Foods of Turlock, California (see Rosenthal and Riefel (1994)) is a producer of high quality dried foods, such as dried onions, garlic, etc. It has regularly received "Supplier of the Year" awards from its customers, retail packaged food manufacturers such as Pillsbury. A reason for Rogers' quality reputation is it tries to supply product to its customers with quality characteristics that closely match customer specifications. This is difficult to do because Rogers does not have complete control over its input. Each food is harvested once per year from a variety of farms, one "lot" per farm. The quality of the crop from each farm is somewhat of a random variable. At harvest time, the crop is dried and each lot placed in the warehouse. Orders throughout the year are then filled from product in the warehouse.

Two of the main quality features of product are its density and its moisture content. Different customers may have different requirements for each quality attribute. If a product is too dense, then a jar that contains five ounces may appear only half full. If a product is not sufficiently dense, it may be impossible to get five ounces into a jar labelled as a five-ounce jar.

To illustrate the problem, suppose you have five lots of product with the following characteristics:

Lot	Fraction Moisture	Density	Kg. Available
1	0.03	0.80	1000
2	0.02	0.75	2500
3	0.04	0.60	3100
4	0.01	0.60	1500
5	0.02	0.65	4500

You currently have two prospective customers with the following requirements:

Customer	Fraction Moisture		Density		Max Kg. Desired	Selling Price per Kg.
	Min	Max	Min	Max		
<i>P</i>	0.035	0.045	0.70	0.75	3,000	\$5.25
<i>G</i>	0.01	0.03	0.60	0.65	15,000	\$4.25

What should you do?

13. The Lexus automobile gets 26 miles per gallon (mpg), the Corolla gets 31 mpg, and the Tercel gets 35 mpg. Let L , C , and T represent the number of automobiles of each type in some fleet. Let F represent the total number in the fleet. We require, in some sense, the mpg of the fleet to be at least 32 mpg. Fleet mpg is measured by (total miles driven by the fleet)/(total gallons of fuel consumed by fleet).
 - a) Suppose the sense in which mpg is measured is each auto is given one gallon of fuel, then driven until the fuel is exhausted. Write appropriate constraints to enforce the 32 mpg requirement.
 - b) Suppose the sense in which mpg is measured is each auto is driven one mile and then stopped. Write appropriate constraints to enforce the 32 mpg requirement.
14. In the financial industry, one is often concerned with the “duration” of one’s portfolio of various financial instruments. The duration of a portfolio is simply the weighted average of the duration of the instruments in the portfolio, where the weight is simply the number of dollars invested in the instrument. Suppose the Second National Bank is considering revising its portfolio and has denoted by $X1$, $X2$, and $X3$, the number of dollars invested (in millions) in each of three different instruments. The durations of the three instruments are respectively: 2 years, 4 years, and 5 years. The following constraint appeared in their planning model:

$$+ X1 - X2 - 2 \times X3 \geq 0$$

In words, this constraint is:

- a) duration of the portfolio must be at most 10 years;
 - b) duration of the portfolio must be at least 3 years;
 - c) duration of the portfolio must be at least 2 years;
 - d) duration of the portfolio must be at most 3 years;
 - e) none of the above.
15. You are manager of a team of ditch diggers, each member of the team is characterized by a productivity measure with units of cubic feet per hour. An average productivity measure for the entire team should be based on which of the following:
- a) the arithmetic mean;
 - b) the geometric mean;
 - c) the harmonic mean.
16. Generic Foods has three different batches of cashews in its warehouse. The percentage moisture content for batches 1, 2, and 3 respectively are 8%, 11%, and 13%. In blending a batch of cashews for a particular customer, the following constraint appeared:

$$+ 2 \times X1 - X2 - 3 \times X3 \geq 0$$

In words, this constraint is:

- a) percent moisture must be at most 10%;
- b) percent moisture must be at least 3%;
- c) percent moisture must be at least 10%;
- d) percent moisture must be at most 2%;
- e) none of the above.

17. The Beanbody Company buys various types of raw coal on the open market and then pulverizes the coal and mixes it to satisfy customer specifications. Last week Beanbody bought 1500 tons of type *M* coal for \$78 per ton that was intended for an order that was canceled at the last minute. Beanbody had to pay an additional \$1 per ton to have the coal shipped to its processing facility. Beanbody has no other coal in stock. Type *M* coal has a BTU content of 13,000 BTU per ton. This week type *M* coal can be bought (or sold) on the open market for \$74 per ton. Type *W* coal, which has a BTU content of 10,000 BTU/ton, can be bought this week for \$68 per ton. Type *K* coal, which has a BTU content of 12,000 BTU/ton, can be bought this week for \$71 per ton. All require an additional \$1/ton to be shipped into Beanbody's facility. In fact, Beanbody occasionally sells raw coal on the open market and then Beanbody also has to pay \$1/ton outbound shipping. Beanbody expects coal prices to continue to drop next week. Right now Beanbody has an order for 2700 tons of pulverized product having a BTU content of at least 11,000 BTU per ton. Clearly, some additional coal must be bought. The president of Beanbody sketched out the following incomplete model for deciding how much of what coal to purchase to just satisfy this order.;

```

MODEL:
! MH = tons of on-hand type M coal used;
! MP = tons of type M coal purchased;
! WP = tons of type W coal purchased;
! KP = tons of type K coal purchased;

MIN = ___ * MH + ___ * MP + ___ * WP + ___ * KP;
MH + MP + WP + KP = 2700;
MH <= 1500;
2000 * MH + _____ * MP - 1000 * WP + _____ * KP >= 0;
END

```

What numbers would you place in the _____ places?

18. A local high school is considering using an outside supplier to provide meals. The big question is: How much will it cost to provide a nutritious meal to a student? Exhibit A reproduces the recommended daily minima for an adult as recommended by the noted dietitian, George Stigler (1945). Because our high school need provide only one meal per day, albeit the main one, it should be sufficient for our meal to satisfy one-half of the minimum daily requirements.

With regard to nutritive content of foods, Exhibit B displays the nutritional content of various foods available from one of the prospective vendors recommended by a student committee at the high school. See Bosch (1993) for a comprehensive discussion of these data.

For preliminary analysis, it is adequate to consider only calories, protein, calcium, iron, vitamins A, B1, and B2.

- Using only the candidate foods and prices in Exhibit B, and allowing fractional portions, what is the minimum cost needed to give a satisfactory meal at our high school?
- Suppose we require only integer portions be served in a meal (e.g., .75 of a Big Mac is not allowed). How is the cost per meal affected?
- Suppose in addition to (b), for meal simplicity, we put a limit of at most three food items from Exhibit B in a meal. For example, a meal of hamburger, fries, chicken McNuggets, and a garden salad has one too many items. How is the cost per meal affected?
- Suppose instead of (c), we require at most one unit per serving of a particular food type be used. How is the cost per meal affected?

- e) Suppose we modify (a) with the condition that the number of grams of fat in the meal must be less-than-or-equal-to $1/20$ th of the total calories in the meal. How is the cost per meal affected?
- f) How is the answer to (a) affected if you use current prices from your neighborhood McDonald's? For reference, Stigler claimed to be able to feed an adult in 1944 for \$59.88 for a full year.

Exhibit A

Nutrient	Allowance
Calories	3,000 calories
Protein	70 grams
Calcium	.8 grams
Iron	12 milligrams
Vitamin A	5,000 International Units
Thiamine (B1)	1.8 milligrams
Riboflavin (B2 or G)	2.7 milligrams
Niacin (Nicotinic Acid)	18 milligrams
Ascorbic Acid (C)	75 milligrams

Exhibit B

Menu Item	Price	Cal.	Protein	Fat	Sodium	Vit A	Vit C	Vit B1	Vit B2	Niacin	Calcium	Iron
Hamburger	0.59	255	12	9	490	4	4	20	10	20	10	15
McLean Deluxe	1.79	320	22	10	670	10	10	25	20	35	15	20
Big Mac	1.65	500	25	26	890	6	2	30	25	35	25	20
Small Fr. Fries	0.68	220	3	12	110	0	15	10	0	10	0	2
Ch. McNuggets	1.56	270	20	15	580	0	0	8	8	40	0	6
Chef Salad	2.69	170	17	9	400	100	35	20	15	20	15	8
Garden Salad	1.96	50	4	2	70	90	35	6	6	2	4	8
Egg McMuffin	1.36	280	18	11	710	10	0	30	20	20	25	15
Wheaties	1.09	90	2	1	220	20	20	20	20	20	2	20
Van. Cone	0.63	105	4	1	80	2	0	2	10	2	10	0
Milk	0.56	110	9	2	130	10	4	8	30	0	30	0
Orange Juice	0.88	80	1	0	0	0	120	10	0	0	0	0
Grapefruit Juice	0.68	80	1	0	0	0	100	4	2	2	0	0
Apple Juice	0.68	90	0	0	5	0	2	2	0	0	0	4

19. Your firm has just developed two new ingredients code named A and B . They seem to have great potential in the automotive after market. These ingredients are blended in various combinations to produce a variety of products. For these products (and for the ingredients themselves), there are three qualities of interest: 1) opacity, 2) friction coefficient, and 3) adhesiveness. The research lab has provided the following table describing the qualities of various combinations of A and B :

Combination	Fraction of		Quality of this Combination		
	A	B	Opacity	Friction coef.	Adhesiveness
1	0.00	1.00	10.0	400.0	.100
2	0.50	0.50	25.0	480.0	.430
3	.75	.25	32.5	533.3	.522
4	1.00	0.00	40.0	600.0	.600

For example, the opacity of B by itself is 10, while the friction coefficient of A by itself is 600.

- For which qualities do the two ingredients appear to interact in a linear fashion?
 - You wish to prepare a product that, among other considerations, has opacity of at least 17, a friction coefficient of at least 430, and adhesiveness of no more than .35. Denote by T , A , and B the amount of total product produced, amount of A used, and the amount of B used. Write the constraints relating T , A , and B to achieve these qualities.
20. Indiana Flange Inc. produces a wide variety of formed steel products it ships to customers all over the country. It uses several different shipping companies to ship these products. The products are shipped in standard size boxes. A shipping company has typically two constraints it has to worry about in assembling a load: a weight constraint and a volume constraint. One of the shippers, Amarillo Freight, handles this issue by putting a density constraint (kilograms/cubic meter) on all shipments it receives from Indiana Flange. If the shipment has a density greater than a certain threshold (110 kg/m^3), Amarillo imposes a surcharge. Currently, Indiana Flange wants to ship the following products to Los Angeles:

Product	Long Tons	Density
A	100	130
B	85	95

Note, there are 1000 kilograms per long ton.

Let AY and BY be the number of tons shipped via Amarillo Freight. Although the densities of products A and B do not change from week to week, the number of tons Indiana Flange needs to ship varies considerably from week to week. Indiana Flange does not want to incur the surcharge. Write a constraint enforcing the Amarillo density constraint that is general (i.e., need not be changed from week to week).

21. The growth of the World Wide Web has dramatically increased the demand for glass fiber optic cable, the main medium used for high capacity data transfer. A major measure of quality of an optical fiber is its transmissivity, the fraction of the light transmitted into the fiber that is emitted out the other end. Suppose you are a fiber optics vendor, with an order in hand for a single 10 km strand of optic fiber, with a required transmissivity of at least .9875 per kilometer at a certain specified wave length of light. You have in stock two types of optic fiber, a) a very expensive one with a transmissivity of .992, and b) a relatively cheap one with a transmissivity of .982. It

has occurred to you that you could sell more of your fiber optic production if you could "blend" some of the lower quality fiber with the high quality. This is in fact possible by splicing a segment of one to the other, e.g., 8 km of the .992 fiber spliced onto 2 km of the .982 fiber. Suppose these splices are very high quality, i.e., no transmission loss across the splice. Let X_H and X_L be the length of high quality and low quality fiber you propose to use for the above request for 10 km of fiber. Write a constraint to ensure satisfaction of the customer's transmissivity requirement.

Formulating and Solving Integer Programs

*“To be or not to be” is true.
-G. Boole*

11.1 Introduction

In many applications of optimization, one would really like the decision variables to be restricted to integer values. One is likely to tolerate a solution recommending GM produce 1,524,328.37 Chevrolets. No one will mind if this recommendation is rounded up or down. If, however, a different study recommends the optimum number of aircraft carriers to build is 1.37, then a lot of people around the world will be very interested in how this number is rounded. It is clear the validity and value of many optimization models could be improved markedly if one could restrict selected decision variables to integer values.

All good commercial optimization modeling systems are augmented with a capability that allows the user to restrict certain decision variables to integer values. The manner in which the user informs the program of this requirement varies from program to program. In LINGO, for example, one way of indicating variable X is to be restricted to integer values is to put it in the model the declaration as: @GIN(X). The important point is it is straightforward to specify this restriction. We shall see later that, even though easy to specify, sometimes it may be difficult to solve problems with this restriction. The methods for formulating and solving problems with integrality requirements are called *integer programming*.

11.1.1 Types of Variables

One general classification is according to types of variables:

Pure vs. mixed. In a pure integer program, all variables are restricted to integer values. In a mixed formulation, only certain of the variables are integer; whereas, the rest are allowed to be continuous.

0/1 vs. general. In many applications, the only integer values allowed are 0/1. Therefore, some integer programming codes assume integer variables are restricted to the values 0 or 1.

The integrality enforcing capability is perhaps more powerful than the reader at first realizes. A frequent use of integer variables in a model is as a zero/one variable to represent a go/no-go decision. It is probably true that the majority of real world integer programs are of the zero/one variety.

11.2 Exploiting the IP Capability: Standard Applications

You will frequently encounter LP problems with the exception of just a few combinatorial complications. Many of these complications are fairly standard. The next several sections describe many of the standard complications along with the methods for incorporating them into an IP formulation. Most of these complications only require the 0/1 capability rather than the general integer capability. Binary variables can be used to represent a wide variety of go/no-go, or make-or-buy decisions. In the latter use, they are sometimes referred to as “Hamlet” variables as in: “To buy or not to buy, that is the question”. Binary variables are sometimes also called Boolean variables in honor of the logician George Boole. He developed the rules of the special algebra, now known as Boolean algebra, for manipulating variables that can take on only two values. In Boole’s case, the values were “True” and “False”. However, it is a minor conceptual leap to represent “True” by the value 1 and “False” by the value 0. The power of these methods developed by Boole is undoubtedly the genesis of the modern compliment: “Strong, like Boole.”

11.2.1 Binary Representation of General Integer Variables

Some algorithms apply to problems with only 0/1 integer variables. Conceptually, this is no limitation, as any general integer variable with a finite range can be represented by a set of 0/1 variables. For example, suppose X is restricted to the set $[0, 1, 2, \dots, 15]$. Introduce the four 0/1 variables: $y_1, y_2, y_3,$ and y_4 . Replace every occurrence of X by $y_1 + 2 \times y_2 + 4 \times y_3 + 8 \times y_4$. Note every possible integer in $[0, 1, 2, \dots, 15]$ can be represented by some setting of the values of $y_1, y_2, y_3,$ and y_4 . Verify that, if the maximum value X can take on is 31, you will need 5 0/1 variables. If the maximum value is 63, you will need 6 0/1 variables. In fact, if you use k 0/1 variables, the maximum value that can be represented is $2^k - 1$. You can write: $VMAX = 2^k - 1$. Taking logs, you can observe that the number of 0/1 variables required in this so-called binary expansion is approximately proportional to the log of the maximum value X can take on.

Although this substitution is valid, it should be avoided if possible. Most integer programming algorithms are not very efficient when applied to models containing this substitution.

11.2.2 Minimum Batch Size Constraints

When there are substantial economies of scale in undertaking an activity regardless of its level, many decision makers will specify a minimum “batch” size for the activity. For example, a large brokerage firm may require that, if you buy any bonds from the firm, you must buy at least 100. A zero/one variable can enforce this restriction as follows. Let:

x = activity level to be determined (e.g., no. of bonds purchased),
 y = a zero/one variable = 1, if and only if $x > 0$,
 B = minimum batch size for x (e.g., 100), and
 U = known upper limit on the value of x .

The following two constraints enforce the minimum batch size condition:

$$\begin{aligned} x &\leq Uy \\ By &\leq x. \end{aligned}$$

If $y = 0$, then the first constraint forces $x = 0$. While, if $y = 1$, the second constraint forces x to be at least B . Thus, y acts as a switch, which forces x to be either 0 or greater than B . The constant U should be chosen with care. For reasons of computational efficiency, it should be as small as validly possible.

Some IP packages allow the user to directly represent minimum batch size requirements by way of so-called semi-continuous variables. A variable x is semi-continuous if it is either 0 or in the range $B \leq x \leq \infty$. No binary variable need be explicitly introduced.

11.2.3 Fixed Charge Problems

A situation closely related to the minimum batch size situation is one where the cost function for an activity is of the fixed plus linear type indicated in Figure 11.1:

Figure 11.1 A Fixed Plus Linear Cost Curve

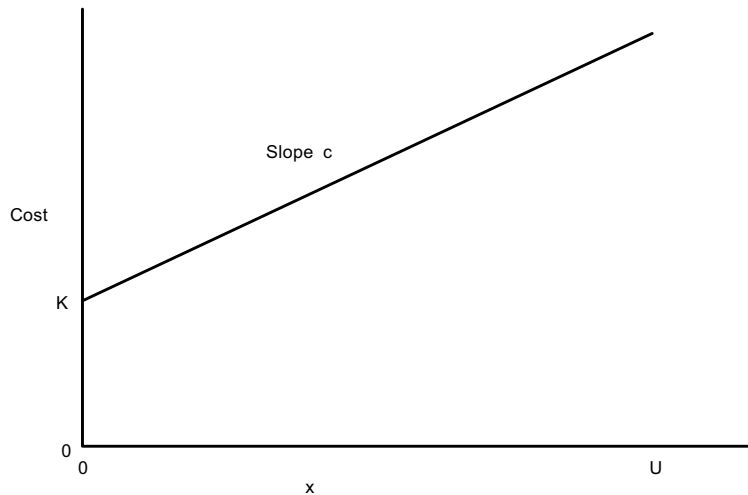

Define x , y , and U as before, and let K be the fixed cost incurred if $x > 0$. Then, the following components should appear in the formulation:

$$\begin{aligned} &\text{Minimize} && Ky + cx + \dots \\ &\text{subject to} && \\ &&& x \leq Uy \\ &&& \vdots \\ &&& \vdots \end{aligned}$$

The constraint and the term Ky in the objective imply x cannot be greater than 0 unless a cost K is incurred. Again, for computational efficiency, U should be as small as validly possible.

11.2.4 The Simple Plant Location Problem

The Simple Plant Location Problem (SPL) is a commonly encountered form of fixed charge problem. It is specified as follows:

- n = the number of sites at which a plant may be located or opened,
- m = the number of customer or demand points, each of which must be assigned to a plant,
- k = the number of plants which may be opened,
- f_i = the fixed cost (e.g., per year) of having a plant at site i , for $i = 1, 2, \dots, n$,
- c_{ij} = cost (e.g., per year) of assigning customer j to a plant at site i , for $i = 1, 2, \dots, n$ and $j = 1, 2, \dots, m$.

The goal is to determine the set of sites at which plants should be located and which site should service each customer.

A situation giving rise to the SPL problem is the lockbox location problem encountered by a firm with customers scattered over a wide area. The plant sites, in this case, correspond to sites at which the firm might locate a postal lockbox that is managed by a bank at the site. The customer points would correspond to the, 100 say, largest metropolitan areas in the firm's market. A customer would mail his or her monthly payments to the closest lockbox. The reason for resorting to multiple lockboxes rather than having all payments mailed to a single site is several days of mail time may be saved. Suppose a firm receives \$60 million per year through the mail. The yearly cost of capital to the firm is 10% per year, and it could reduce the mail time by two days. This reduction has a yearly value of about \$30,000.

The f_i for a particular site would equal the yearly cost of having a lockbox at site i regardless of the volume processed through the site. The cost term c_{ij} would approximately equal the product: (daily cost of capital) \times (mail time in days between i and j) \times (yearly dollar volume mailed from area j).

Define the decision variables:

$$y_i = 1 \text{ if a plant is located at site } i, \text{ else } 0,$$

$$x_{ij} = 1 \text{ if the customer } j \text{ is assigned to a plant site } i, \text{ else } 0.$$

A compact formulation of this problem as an IP is:

$$\text{Minimize } \sum_{i=1}^n f_i y_i + \sum_{i=1}^n \sum_{j=1}^m c_{ij} x_{ij} \quad (1)$$

$$\text{subject to } \sum_{i=1}^n x_{ij} = 1 \quad \text{for } j = 1 \text{ to } m, \quad (2)$$

$$\sum_{j=1}^m x_{ij} \leq m y_i \quad \text{for } i = 1 \text{ to } n, \quad (3)$$

$$\sum_{i=1}^n y_i = k, \quad (4)$$

$$y_i = 0 \text{ or } 1 \quad \text{for } i = 1 \text{ to } n, \quad (5)$$

$$x_{ij} = 0 \text{ or } 1 \quad \text{for } i = 1 \text{ to } n, j = 1 \text{ to } m. \quad (6)$$

The constraints in (2) force each customer j to be assigned to exactly one site. The constraints in (3) force a plant to be located at site i if any customer is assigned to site i .

The reader should be cautioned against trying to solve a problem formulated in this fashion because the solution process may require embarrassingly much computer time for all, but the smallest problem. The difficulty arises because, when the problem is solved as an LP (i.e., with the conditions in (5) and (6) deleted), the solution tends to be highly fractional and with little similarity to the optimal IP solution.

A "tighter" formulation, which frequently produces an integer solution naturally when solved as an LP, is obtained by replacing (3) by the formula:

$$x_{ij} \leq y_i \text{ for } i = 1 \text{ to } n, j = 1 \text{ to } m. \quad (3')$$

At first glance, replacing (3) by (3') may seem counterproductive. If there are 20 possible plant sites and 60 customers, then the set (3) would contain 20 constraints, whereas set (3') would contain $20 \times 60 = 1,200$ constraints. Empirically, however, it appears to be the rule rather than the exception that, when the problem is solved as an LP with (3') rather than (3), the solution is naturally integer.

11.2.5 The Capacitated Plant Location Problem (CPL)

The CPL problem arises from the SPL problem if the volume of demand processed through a particular plant is an important consideration. In particular, the CPL problem assumes each customer has a known volume and each plant site has a known volume limit on total volume assigned to it. The additional parameters to be defined are:

D_j = volume or demand associated with customer j ,
 K_i = capacity of a plant located at i

The IP formulation is:

$$\text{Minimize} \quad \sum_{i=1}^n f_i y_i + \sum_{i=1}^n \sum_{j=1}^m c_{ij} x_{ij} \quad (7)$$

$$\text{subject to} \quad \sum_{i=1}^n x_{ij} = 1 \quad \text{for } j = 1 \text{ to } m \quad (8)$$

$$\sum_{j=1}^m D_j x_{ij} \leq K_i y_i \quad \text{for } i = 1 \text{ to } n \quad (9)$$

$$x_{ij} \leq y_i \quad \text{for } i = 1 \text{ to } n, j = 1 \text{ to } m. \quad (10)$$

$$y_i = 0 \text{ or } 1 \quad \text{for } i = 1 \text{ to } n \quad (11)$$

$$x_{ij} = 0 \text{ or } 1 \quad \text{for } i = 1 \text{ to } n, j = 1 \text{ to } m. \quad (12)$$

This is the “single-sourcing” version of the problem. Because the variables x_{ij} are restricted to 0 or 1, each customer must have all of its volume assigned to a single plant. If “split-sourcing” is allowed, then the variables x_{ij} are allowed to be fractional with the interpretation that x_{ij} is the fraction of customer j 's volume assigned to plant site i . In this case, condition (12) is dropped. Split sourcing, considered alone, is usually undesirable. An example is the assignment of elementary schools to high schools. Students who went to the same elementary school prefer to be assigned to the same high school.

Example: Capacitated Plant Location

Some of the points just mentioned will be illustrated with the following example.

The Zzyzx Company of Zzyzx, California currently has a warehouse in each of the following cities: (A) Baltimore, (B) Cheyenne, (C) Salt Lake City, (D) Memphis, and (E) Wichita. These warehouses supply customer regions throughout the U.S. It is convenient to aggregate customer areas and consider the customers to be located in the following cities: (1) Atlanta, (2) Boston, (3) Chicago, (4) Denver, (5) Omaha, and (6) Portland, Oregon. There is some feeling that Zzyzx is “overwarehoused”. That is, it may be able to save substantial fixed costs by closing some warehouses without unduly increasing transportation and service costs. Relevant data has been collected and assembled on a “per month” basis and is displayed below:

Warehouse	Demand City						Monthly Supply Capacity in Tons	Monthly Fixed Cost
	1	2	3	4	5	6		
A	\$1675	\$400	\$685	\$1630	\$1160	\$2800	18	\$7,650
B	1460	1940	970	100	495	1200	24	3,500
C	1925	2400	1425	500	950	800	27	3,500
D	380	1355	543	1045	665	2321	22	4,100
E	922	1646	700	508	311	1797	31	2,200
Monthly Demand in Tons	10	8	12	6	7	11		

For example, closing the warehouse at *A* (Baltimore) would result in a monthly fixed cost saving of \$7,650. If 5 (Omaha) gets all of its monthly demand from *E* (Wichita), then the associated transportation cost for supplying Omaha is $7 \times 311 = \$2,177$ per month. A customer need not get all of its supply from a single source. Such “multiple sourcing” may result from the limited capacity of each warehouse (e.g., Cheyenne can only process 24 tons per month. Should Zzyzx close any warehouses and, if so, which ones?)

We will compare the performance of four different methods for solving, or approximately solving, this problem:

- 1) Loose formulation of the IP.
- 2) Tight formulation of the IP.
- 3) Greedy open heuristic: start with no plants open and sequentially open the plant giving the greatest reduction in cost until it is worthless to open further plants.
- 4) Greedy close heuristic: start with all plants open and sequentially close the plant saving the most money until it is worthless to close further plants.

The advantage of heuristics 3 and 4 is they are easy to apply. The performance of the four methods is as follows:

Method	Objective value: Best Solution	Computing Time in Seconds	Plants Open	Objective value: LP Solution
Loose IP	46,031	3.38	A,B,D	35,662
Tight IP	46,031	1.67	A,B,D	46,031
Greedy Open Heuristic	46,943	nil	A,B,D,E	—
Greedy Close Heuristic	46,443	nil	A,C,D,E	—

Notice, even though the loose IP finds the same optimum as the tight formulation (as it must), it takes about twice as much computing time. For large problems, the difference becomes much more dramatic. Notice for the tight formulation, however, the objective function value for the LP solution is the same as for the IP solution. When the tight formulation was *solved as an LP*, the solution was naturally integer.

The single product dynamic lotsizing problem is described by the following parameters:

- n = number of periods for which production is to be planned for a product;
- D_j = predicted demand in period j , for $j = 1, 2, \dots, n$;
- f_i = fixed cost of making a production run in period i ;
- h_i = cost per unit of product carried from period i to $i + 1$.

This problem can be cast as a simple plant location problem if we define:

$$c_{ij} = D_j \sum_{r=i}^{j-1} h_r.$$

That is, c_{ij} is the cost of supplying period j 's demand from period i production. Each period can be thought of as both a potential plant site (period for a production run) and a customer.

If, further, there is a finite production capacity, K_i , in period i , then this capacitated dynamic lotsizing problem is a special case of the capacitated plant location problem.

Dual Prices and Reduced Costs in Integer Programs

Dual prices and reduced costs in solution reports for integer programs have a restricted interpretation. For first time users of IP, it is best to simply disregard the reduced cost and dual price column in the solution report. For the more curious, the dual prices and reduced costs in a solution report are obtained from the linear program that remains after all integer variables have been fixed at their optimal values and removed from the model. Thus, for a pure integer program (i.e., all variables are required to be integer), you will generally find:

- all dual prices are zero, and
- the reduced cost of a variable is simply its objective function coefficient (with sign reversed if the objective is MAX).

For mixed integer programs, the dual prices may be of interest. For example, for a plant location problem where the location variables are required to be integer, but the quantity-shipped variables are continuous, the dual prices reported are those from the continuous problem where the locations of plants have been specified beforehand (at the optimal locations).

11.2.6 Modeling Alternatives with the Scenario Approach

We may be confronted by alternatives in two different ways: a) we have to choose among two or more alternatives and we want to figure out which is best, or b) nature or the market place will choose one of two or more alternatives, and we are not sure which alternative nature will choose, so we want to analyze all alternatives so we will be prepared to react optimally once we learn which alternative was chosen by nature. Here we consider only situation (a). We call the approach the scenario approach or the disjunctive formulation, see for example Balas(1979) or section 16.2.3 of Martin(1999).

Suppose that if we disregard the alternatives, our variables are simply called x_1, x_2, \dots, x_n . We call the conditions that must hold if alternative s is chosen, scenario s . Without too much loss of generality, we assume all variables are non-negative. The scenario/disjunctive approach to formulating a discrete decision problem proceeds as follows:

For each scenario s :

- 1) Write all the constraints that must hold if scenario s is chosen.
- 2) For all variables in these constraints add a subscript s , to distinguish them from equivalent variables in other scenarios. So x_j in scenario s becomes x_{sj} .
- 3) Add a 0/1 variable, y_s , to the model with the interpretation that $y_s = 1$ if scenario s is chosen, else 0.
- 4) Multiply the RHS constant term of each constraint in scenario s by y_s .
- 5) For each variable x_{sj} that appears in any of the scenario s constraints, add the constraint:

$$x_{sj} \leq M^* y_s$$
, where M is a large positive constant. The purpose of this step is to force all variables in scenario s to be 0 if scenario s is not chosen.

Finally, we tie all the scenarios together with:

$$\sum_s y_s = 1, \text{ i.e., we must choose one scenario;}$$

For each variable x_j , add the constraint:

$$x_j = \sum_s x_{sj}, \text{ so } x_j \text{ takes on the value appropriate to which scenario was chosen.}$$

For example, if just after step 1 we had a constraint of the form:

$$\sum_j a_{sj} * x_j \leq a_{s0},$$

then steps 2-4 would convert it to:

$$\sum_j a_{sj} * x_{sj} \leq a_{s0} * y_s,$$

The forcing constraints in step 5 are not needed if $y_s = 0$ implies $x_{sj} = 0$, e.g., if all the a_{sj} are nonnegative and the x_j are constrained to be nonnegative.

The next section illustrates the scenario approach for representing a decision problem.

11.2.7 Linearizing a Piecewise Linear Function

If you ask a vendor to provide a quote for selling you some quantity of material, the vendor will typically offer a quantity discount function that looks something like that shown in figure 11.2

Figure 11.2 Quantity Discount Piecewise Linear Cost Curve

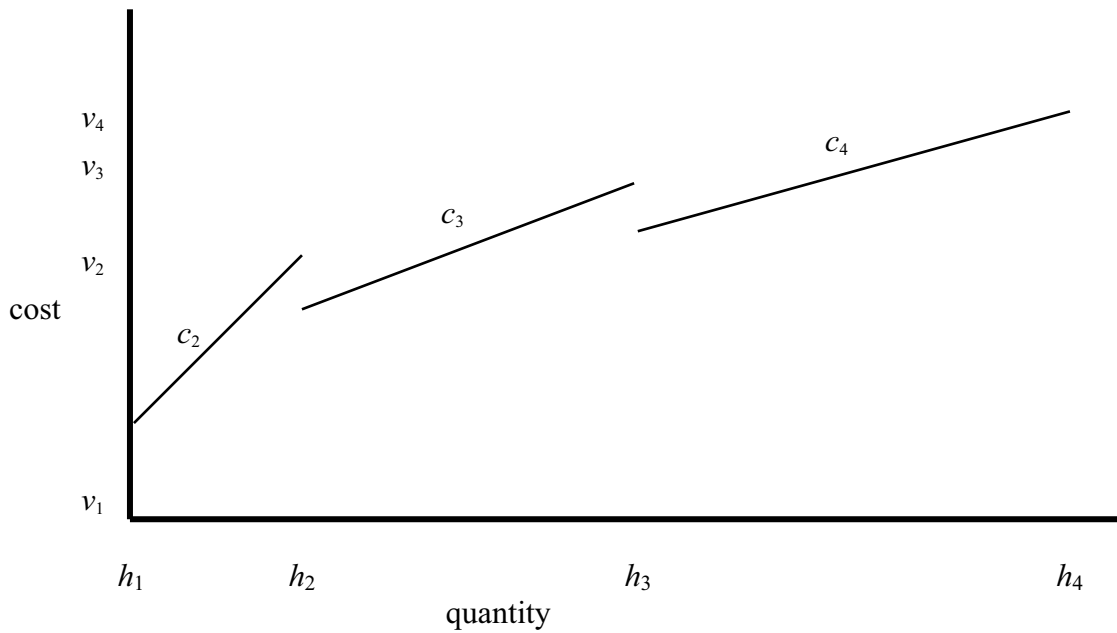

Define:

h_s, v_s = coordinates of the rightmost point of segment s of the piecewise linear function,
 c_s = slope of segment s ,

Note that segment 1 is the degenerate segment of buying nothing. This example illustrates that we do not require that a piecewise linear function be continuous.

Let us consider the following situation:

We pay \$50 if we buy anything in a period, plus
 \$2.00/unit if quantity < 100,
 \$1.90/unit if quantity ≥ 100 but < 1000,
 \$1.80/unit if ≤ 1000 but ≤ 5000 .

We assume h_s, v_s, c_s are constants, and $h_s \leq h_{s+1}$. It then follows that:

h	v	$c =$
0	0	0
100	250	2
1000	1950	1.90
5000	9050	1.80;

Let x denote the amount we decide to purchase. Using step 1 of the scenario formulation approach,

If segment/scenario 1 is chosen, then

$$\begin{aligned} \text{cost} &= 0; \\ x &= 0; \end{aligned}$$

If segment/scenario 2 is chosen, then

$$\begin{aligned} \text{cost} &= v_2 - c_2*(h_2 - x); & [\text{or } 250 - 2*(100 - x)], \\ x &\leq h_2; & [\text{or } x \leq 100], \\ x &\geq h_1; & [\text{or } x \geq 0], \end{aligned}$$

Similar constraints apply for scenario/segments 3 and 4. We assume that fractional values, such as $x = 99.44$ are allowed, else we would write $x \leq 99$ rather than $x \leq 100$ above.

If we apply steps 2-4 of the scenario formulation method, then we get:

For segment/scenario 1 is chosen, then

$$\begin{aligned} \text{cost}_1 &= 0; \\ x_1 &= 0; \end{aligned}$$

If segment/scenario 2 is chosen, then

$$\begin{aligned} \text{cost}_2 &= v_2*y_2 - c_2*h_2*y_2 + c_2*x_2; & [\text{ or } \text{cost}_2 = 50*y_2 + 2*x_2], \\ x_2 &\leq h_2*y_2; & [\text{ or } x_2 \leq 100*y_2], \\ x_2 &\geq h_1*y_2; & [\text{ or } x_2 \geq 0*y_2], \end{aligned}$$

If segment/scenario 3 is chosen, then

$$\begin{aligned} \text{cost}_3 &= v_3*y_3 - c_3*h_3*y_3 + c_3*x_3; & [\text{ or } \text{cost}_3 = 50*y_3 + 1.9*x_3], \\ x_3 &\leq h_3*y_3; & [\text{ or } x_3 \leq 1000*y_3], \\ x_3 &\geq h_2*y_3; & [\text{ or } x_3 \geq 100*y_3], \end{aligned}$$

If segment/scenario 4 is chosen, then

$$\begin{aligned} \text{cost}_4 &= v_4*y_4 - c_4*h_4*y_4 + c_4*x_4; & [\text{ or } \text{cost}_4 = 50*y_3 + 1.8*x_4] \\ x_4 &\leq h_4*y_4; & [\text{ or } x_3 \leq 5000*y_4], \\ x_4 &\geq h_3*y_4; & [\text{ or } x_3 \geq 1000*y_4], \end{aligned}$$

We must choose one of the four segments, so:

$$\begin{aligned} y_1 + y_2 + y_3 + y_4 &= 1; \\ y_1, y_2, y_3, y_4 &= 0 \text{ or } 1; \end{aligned}$$

and the true quantity and cost are found with:

$$\begin{aligned} x_1 + x_2 + x_3 + x_4 &= x; \\ \text{cost}_1 + \text{cost}_2 + \text{cost}_3 + \text{cost}_4 &= \text{cost}; \end{aligned}$$

Example

The previous quantity discount example illustrated what is called an “all units discount”. Sometimes, a vendor will instead quote an incremental units discount, in which the discount applies only to the units above a threshold. The following example illustrates. There is a fixed cost of \$150 for placing an order. The first 1,000 gallons of the product can be purchased for \$2 per gallon. The price drops to \$1.90 per gallon for anything in excess of 1,000 gallons. At most, 5,000 gallons will be purchased. Using the scenario/disjunctive approach again.

Define the variables:

$y_0 = 1$ if nothing is bought, else 0;
 $y_1 = 1$ if more than 0, but no more than 1000, gallons are purchased, else 0;
 $y_2 = 1$ if more than 1,000 gallons are purchased, else 0;
 $x_1 =$ gallons purchased if no more than 1,000 gallons are purchased;
 $x_2 =$ gallons purchased if more than 1,000 gallons are purchased.

The formulation would include:

```

MIN = cost + ...;
!s.t.;
! Segment/scenario 1;
  cost1 = 150*y1 + 2*x1;
  x1 <= 1000 *y1;
! Segment/scenario 2;
  cost2 = (150 + (2.0-1.9)*1000)*y1 + 1.9*x2;
  x2 >= 1000*y2;
  x2 <= 5000*y2;
! Choose a scenario/segment;
  y0 + y1 + y2 = 1;
  cost1 + cost2 = cost;
  x1 + x2 = x;
  @BIN(y1); @BIN(y2);
! Plus other constraints & variables to complete model;
  
```

11.2.8 Converting to Separable Functions

The previous method is applicable only to nonlinear functions of one variable. There are some standard methods available for transforming a function of several variables, so a function is obtained that is additively separable in the transformed variables. The most common such transformation is for converting a product of two variables into separable form. For example, given the function:

$$x_1 * x_2,$$

add the linear constraints:

$$y_1 = (x_1 + x_2)/2$$

$$y_2 = (x_1 - x_2)/2.$$

Then, replace every instance of $x_1 * x_2$ by the term $y_1^2 - y_2^2$. That is, the claim is:

$$x_1 * x_2 = y_1^2 - y_2^2.$$

The justification is observed by noting:

$$y_1^2 - y_2^2 = (x_1^2 + 2 * x_1 * x_2 + x_2^2)/4$$

$$- (x_1^2 - 2 * x_1 * x_2 + x_2^2)/4$$

$$= 4 * x_1 * x_2 /4 = x_1 * x_2$$

This example suggests that, any time you have a product of two variables, you can add two new variables to the model and replace the product term by a sum of two squared variables. If you have n original variables, you could have up to $n(n-1)/2$ cross product terms. This suggests that you might

need up to $n(n-1)$ new variables to get rid of all cross product terms. In fact, under certain conditions, the above ideas can be generalized (using the technique of Cholesky factorization), so only n new variables are needed.

11.3 Outline of Integer Programming Methods

The time a computer requires to solve an IP may depend dramatically on how you formulated it. It is, therefore, worthwhile to know a little about how IPs are solved. There are two general approaches for solving IPs: “cutting plane” methods and “branch-and-bound” (B & B) method. For a comprehensive introduction to integer programming solution methods, see Nemhauser and Wolsey (1988), and Wolsey (1998). Most commercial IP programs use the B & B method, but aided by some cutting plane features. Fortunately for the reader, the B & B method is the easier to describe. In most general terms, B & B is a form of intelligent enumeration.

More specifically, B & B first solves the problem as an LP. If the LP solution is integer valued in the integer variables, then no more work is required. Otherwise, B & B resorts to an intelligent search of all possible ways of rounding the fractional variables.

We shall illustrate the application of the branch-and-bound method with the following problem:

$$\begin{aligned} \text{MAX} &= 75 * X1 + 6 * X2 + 3 * X3 + 33 * X4; \\ 774 * X1 + 76 * X2 + 22 * X3 + 42 * X4 &\leq 875; \\ 67 * X1 + 27 * X2 + 794 * X3 + 53 * X4 &\leq 875; \\ @\text{BIN}(X1); @\text{BIN}(X2); @\text{BIN}(X3); @\text{BIN}(X4); \end{aligned}$$

The search process a computer might follow in finding an integer optimum is illustrated in Figure 11.4. First, the problem is solved as an LP with the constraints $X1, X2, X3, X4 \leq 1$. This solution is summarized in the box labeled 1. The solution has fractional values for $X2$ and $X3$ and is, therefore, unacceptable. At this point, $X2$ is arbitrarily selected and the following reasoning is applied. At the integer optimum, $X2$ must equal either 0 or 1.

Figure 11.4 Branch-and-Bound Search Tree

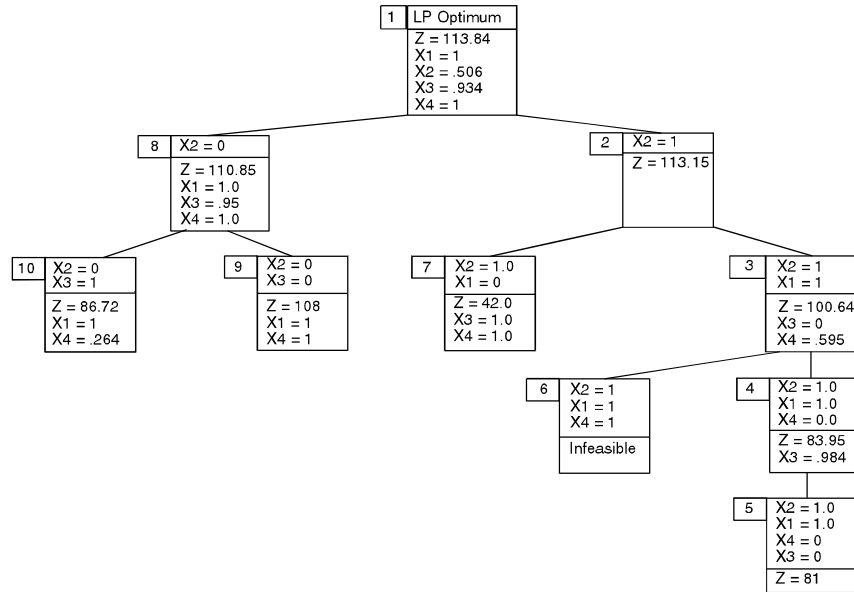

Therefore, replace the original problem by two new subproblems. One with X_2 constrained to equal 1 (box or node 2) and the other with X_2 constrained to equal 0 (node 8). If we solve both of these new IPs, then the better solution must be the best solution to the original problem. This reasoning is the motivation for using the term “branch”. Each subproblem created corresponds to a branch in an enumeration tree.

The numbers to the upper left of each node indicate the order in which the nodes (or equivalently, subproblems) are examined. The variable Z is the objective function value. When the subproblem with X_2 constrained to 1 (node 2) is solved as an LP, we find X_1 and X_3 take fractional values. If we argue as before, but now with variable X_1 , two new subproblems are created:

- Node 7) one with X_1 constrained to 0, and
- Node 3) one with X_1 constrained to 1.

This process is repeated with X_4 and X_3 until node 5. At this point, an integer solution with $Z = 81$ is found. We do not know this is the optimum integer solution, however, because we must still look at subproblems 6 through 10. Subproblem 6 need not be pursued further because there are no feasible solutions having all of X_2 , X_1 , and X_4 equal to 1. Subproblem 7 need not be pursued further because it has a Z of 42, which is worse than an integer solution already in hand.

At node 9, a new and better integer solution with $Z = 108$ is found when X_3 is set to 0. Node 10 illustrates the source for the “bound” part of “branch-and-bound”. The solution is fractional. However, it is not examined further because the Z -value of 86.72 is less than the 108 associated with an integer solution already in hand. The Z -value at any node is a bound on the Z -value at any offspring node. This is true because an offspring node or subproblem is obtained by appending a constraint to the parent problem. Appending a constraint can only hurt. Interpreted in another light, this means the Z -values cannot improve as one moves down the tree. The tree presented in the preceding figure was only one illustration of how the tree might be searched. Other trees could be developed for the same problem by playing with the following two degrees of freedom:

- (a) Choice of next node to examine, and
- (b) Choice of how the chosen node is split into two or more subnodes.

For example, if nodes 8 and then 9 were examined immediately after node 1, then the solution with $Z = 108$ would have been found quickly. Further, nodes 4, 5, and 6 could then have been skipped because the Z -value at node 3 (100.64) is worse than a known integer solution (108), and, therefore, no offspring of node 3 would need examination.

In the example tree, the first node is split by branching on the possible values for X_2 . One could have just as well chosen X_3 or even X_1 as the first branching variable.

The efficiency of the search is closely related to how wisely the choices are made in (a) and (b) above. Typically, in (b) the split is made by branching on a single variable. For example, if, in the continuous solution, $x = 1.6$, then the obvious split is to create two subproblems. One with the constraint $x \leq 1$, and the other with the constraint $x \geq 2$. The split need not be made on a single variable. It could be based on an arbitrary constraint. For example, the first subproblem might be based on the constraint $x_1 + x_2 + x_3 \leq 0$, while the second is obtained by appending the constraint $x_1 + x_2 + x_3 \geq 1$. Also, the split need not be binary. For example, if the model contains the constraint $y_1 + y_2 + y_3 = 1$, then one could create three subproblems corresponding to either $y_1 = 1$, or $y_2 = 1$, or $y_3 = 1$.

If the split is based on a single variable, then one wants to choose variables that are “decisive.” In general, the computer will make intelligent choices and the user need not be aware of the details of the search process. The user should, however, keep the general B & B process in mind when formulating a model. If the user has *a priori* knowledge that an integer variable x is decisive, then for the LINGO program it is useful to place x early in the formulation to indicate its importance. This general understanding should drive home the importance of a “tight” LP formulation. A tight LP formulation is one which, when solved, has an objective function value close to the IP optimum. The LP solutions at the subproblems are used as bounds to curtail the search. If the bounds are poor, many early nodes in the tree may be explicitly examined because their bounds look good even though, in fact, these nodes have no good offspring.

11.4 Computational Difficulty of Integer Programs

Integer programs can be very difficult to solve. This is in marked contrast to LP problems. The solution time for an LP is fairly predictable. For an LP, the time increases approximately proportionally with the number of variables and approximately with the square of the number of constraints. For a given IP problem, the time may in fact decrease as the number of constraints is increased. As the number of integer variables is increased, the solution time may increase dramatically. Some small IPs (e.g., 6 constraints, 60 variables) are extremely difficult to solve.

Just as with LPs, there may be alternate IP formulations of a given problem. With IPs, however, the solution time generally depends critically upon the formulation. Producing a good IP formulation

requires skill. For many of the problems in the remainder of this chapter, the difference between a good formulation and a poor formulation may be the difference between whether the problem is solvable or not.

11.4.1 NP-Complete Problems

Integer programs belong to a class of problems known as *NP*-hard. We may somewhat loosely think of *NP* as meaning "not polynomial". This means that there is no known algorithm of solving these problems such that the computational effort at worst increases as a polynomial in the problem size. For our purposes, we will say that an algorithm runs in polynomial time if there is a positive constant k , such that the time to solve a problem of size n is proportional to n^k . For example, sorting a set of n numbers can easily be done in (polynomial) time proportional to n^2 , ($n \log(n)$ if one is careful), whereas solving an integer program in n zero/one variables may, in the worst case, take (exponential) time proportional to 2^n . There may be a faster way, but no one has published an algorithm for integer programs that is guaranteed to take polynomial time on every problem presented to it. The terms *NP*-complete and *P*-complete apply to problems that can be stated as "yes/no" or feasibility problems. The yes/no variation of an optimization problem would be a problem of the form: Is there a feasible solution to this problem with cost less-than-or-equal-to 1250. In an optimization problem, we want a feasible solution with minimum cost. Khachian (1979) showed that the feasibility version of LP is solvable in polynomial time. So, we say LP is in *P*. Integer programming stated in feasibility form, and a wide range of similar problems, belong to a class of problems called *NP*-complete. These problems have the feature that it is possible to convert any one of these problems into any other *NP*-complete problem in time that is polynomial in the problem size. Thus, if we can convert problem A into problem B in polynomial time, then solve B in polynomial time, and then convert the solution to B to a valid solution to A in polynomial time, we then have a way of solving A in polynomial time.

The notable thing about *NP*-complete problems is that, if someone develops a guaranteed fast (e.g., polynomial worst case) time method for solving one of these problems, then that someone also has a polynomial time algorithm for every other *NP*-complete problem. An important point to remember is that the *NP*-completeness classification is defined in terms of worst case behavior, not average case behavior. For practical purposes, one is interested mainly in average case behavior. The current situation is that the average time to solve many important practical integer programming problems is quite short. The fact that someone may occasionally present us with an extremely difficult integer programming problem does not prevent us from profiting from the fact that a large number of practical integer programs can be solved rapidly. Perhaps the biggest open problem in modern mathematics is whether the problems in the *NP*-complete class are inherently difficult. This question is cryptically phrased as is: $P = NP$? Are these problems really difficult, or is it that we are just not smart enough to discover the universally fast algorithm? In fact, a "Millenium prize" of \$1,000,000 is offered by the Clay Mathematics Institute, www.claymath.org, for an answer to this question. For a more comprehensive discussion of the *NP*-complete classification, see Martin (1999).

11.5 Problems with Naturally Integer Solutions and the Prayer Algorithm

The solution algorithms for IP are generally based on first solving the IP as an LP by disregarding the integrality requirements and praying the solution is naturally integer. For example, if x is required to be 0 or 1, the problem is first solved by replacing this requirement by the requirement that simply $0 \leq x \leq 1$. When initiating the analysis of a problem in which integer answers are important, it is useful to know beforehand whether the resulting IP will be easy to solve. After the fact, one generally

observes the IP was easy to solve if the objective function values for the LP optimum and the IP optimum were close. About the only way we can predict beforehand the objective function values of the LP and IP will be close is if we know beforehand the LP solution will be almost completely integer valued. Thus, we are interested in knowing what kinds of LPs have naturally integer solutions.

The classes of LP problems for which we know beforehand there is a naturally integer optimum have integer right-hand sides and are in one of the classes:

- (a) Network LPs,
- (b) MRP or Integral Leontief LPs,
- (c) Problems that can be transformed to (a) or (b) by either row operations or taking the dual.

We first review the distinguishing features of network and MRP LPs.

11.5.1 Network LPs Revisited

A LP is said to be a network LP if: 1) disregarding simple upper and lower bound constraints (such as $x \leq 3$), each variable appears in at most two constraints, and 2) if each variable appears in two constraints, its coefficients in the two are +1 and -1. If the variable appears in one constraint, its coefficient is either +1 or -1.

Result: If the right-hand side is integer, then there is an integer optimum. If the objective coefficients are all integer, then there is an optimum with integral dual prices.

11.5.2 Integral Leontief Constraints

A constraint set is said to be *integral Leontief* or MRP (for Material Requirements Planning) if (see Jeroslow, Martin, et al. (1992)):

- Each constraint is an equality,
- Every column has exactly one positive coefficient and it is a +1,
- Each column has 0 or more negative coefficients, every one of which is integer,
- Each RHS coefficient is a nonnegative integer.

Result: An LP whose complete constraint set is an MRP set has an optimal solution that is integer. Further, if the objective coefficients are all integer, then there is an optimal solution with integral dual prices.

11.5.3 Example: A One-Period MRP Problem

The Schwindle Cycle Company makes three products: Unicycles (U), Regular Bicycles (R), and Twinbikes (T). Each product is assembled from a variety of components including: seats (S), wheels (W), hubs (H), spokes (P), chains (C), and links (L). The full bills of materials for each product are shown below. The numbers in parentheses specify how many units of the child are required per parent:

Figure 11.5 MRP Structure for Bicycles

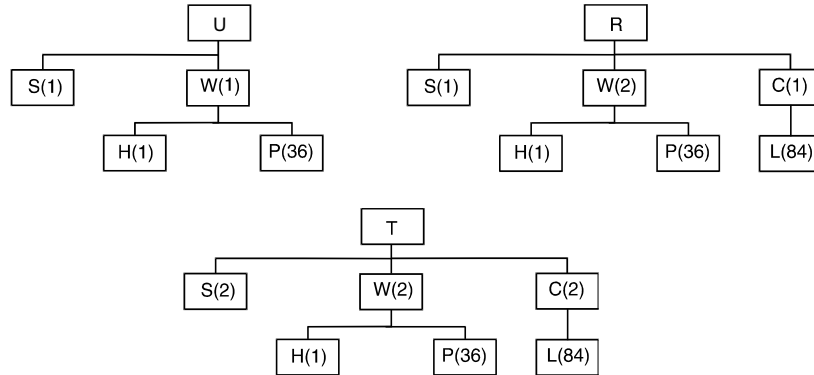

Current inventories are zero. Schwindle needs to supply 100 Unicycles, 500 Regular bicycles, and 200 Twinbikes. Finished products and complete sub-assemblies can be either manufactured or bought at the following prices:

Item:	U	R	T	S	W	C	H	P	L
Bought Price:	2.60	5.2	3.10	0.25	1.40	0.96	0.19	0.07	0.05
Assembly Cost:	1.04	1.16	1.90	0.20	0.22	0.26	0.16	0.04	0.03

Note the assembly cost is the immediate cost at the level of assembly. It does not include the cost of the components going into the assembly. How many units of each item should be made or bought to satisfy demand at minimum price?

An LP formulation is:

```

MODEL:
SETS:
  TYPES/U, R, T/:M, B, MP, BP, NEED;
  MATERIALS/S, W, C/:MM, MB, MMP, MBP;
  SUBMATS/H, P, L/:SMM, SMB, SMP, SBP;
  REQ(TYPES, MATERIALS): MATREQ;
  MREQ(MATERIALS, SUBMATS): SMATREQ;
ENDSETS
DATA:
  NEED    = 100 500 200;
  MP      = 1.04 1.16 1.9;
  BP      = 2.6 5.2 3.1;
  MMP     = .2 .22 .26;
  MBP     = .25 1.4 .96;
  SMP     = .16 .04 .03;
  SBP     = .19 .07 .05;
  MATREQ  = 1 1 0
           1 2 1
           2 2 2;
  SMATREQ = 0 0 0
           1 36 0
           0 0 84;
ENDDATA
  MIN = @SUM(TYPES : M * MP + B * BP)
        + @SUM(MATERIALS : MM * MMP + MB * MBP)
        + @SUM(SUBMATS: SMM * SMP + SMB * SBP);
  @FOR(TYPES: M + B = NEED);
  @FOR(MATERIALS(I): MM(I) + MB(I) =
        @SUM(TYPES(J): M(J) * MATREQ(J, I)));
  @FOR(SUBMATS(I): SMM(I) + SMB(I) =
        @SUM(MATERIALS(J): MM(J) * SMATREQ(J, I)));
END

```

In the PICTURE of the formulation below, notice it has the MRP structure:

```

          U U R R T T S S W W C C H H P P L L
          M B M B M B M B M B M B M B M B M B
1: A A A A A A T T T A T T T U U U U U MIN
UNICYCLE: 1 1 ' ' ' ' ' ' ' ' ' ' ' ' = B
REGULAR: ' '1 1 ' ' ' ' ' ' ' ' ' ' = C
TWINBIKE: ' '1 1 ' ' ' ' ' ' ' ' ' ' = C
SEATS:-1 -1 '-2 1 1 ' ' ' ' ' ' =
WHEELS:-1 -2 '-2' ' '1 1 ' ' ' ' ' ' =
CHAINS: -1 '-2 ' ' ' '1 1 ' ' ' ' =
HUBS: ' ' ' ' ' -1 ' '1 1 ' ' =
SPOKES: ' ' ' ' ' -B ' ' ' '1 1 ' =
LINKS: ' ' ' ' '-B ' ' '1 1 =

```

The solution is:

```

Optimal solution found at step:          0
Objective value:                        3440.000
Variable      Value      Reduced Cost
M( R)         500.0000      0.0000000
B( U)         100.0000      0.0000000
B( T)         200.0000      0.0000000
MM( S)        500.0000      0.0000000
MB( W)        1000.000      0.0000000
MB( C)         500.0000      0.0000000
    
```

Notice it is naturally integer. Thus, we should buy all the unicycles and twin bikes (and paste our own brand name on them). We assemble our own regular bicycles. They are assembled from manufactured seats and bought wheels and chains.

If we put an upper limit of 300 on the number of links manufactured by adding the constraint $LM \leq 300$, we will get a fractional solution because this constraint violates the MRP structure.

11.5.4 Transformations to Naturally Integer Formulations

A *row operation* consists of either of the following:

- multiplication through an equation by some non-zero constant,
- adding a finite multiple of one equation to another.

A row operation changes neither the feasible region nor the set of optimal solutions to a problem. Thus, if we can show a model can be transformed to either a network LP or an MRP LP by row operations, then we know there is an integer optimum. We do not actually need to do the transformation to get the solution.

Similarly, if we have a model with an integer right-hand side and we can show it is the dual of either a network LP or an MRP LP, then we know the model has an integer optimum.

Example

Consider the following LP that arose in planning how much to produce in each of four periods:

```

      P P P P P P P P P
      1 1 1 1 2 2 2 3 3 4
      4 3 2 1 4 3 2 4 3 4
1:   9 6 4 3 6 4 3 4 3 3 MIN
2:   1 1 1 1
3:   1 1 1   1 1 1
4:   1 1     1 1   1 1
5:   1       1     1 1
    
```

When solved as an LP, we obtained the following naturally integer solution:

$P12 = P34 = 1$; all others 0.

Could we have predicted a naturally integer solution beforehand? If we perform the row operations: $(5') = (5) - (4)$; $(4') = (4) - (3)$; $(3') = (3) - (2)$, we obtain the equivalent LP:

$$\begin{array}{cccccccccccc}
 & P & P & P & P & P & P & P & P & P & P & P \\
 & 1 & 1 & 1 & 1 & 2 & 2 & 2 & 3 & 3 & 4 & \\
 & 4 & 3 & 2 & 1 & 4 & 3 & 2 & 4 & 3 & 4 & \\
 1: & 9 & 6 & 4 & 3 & 6 & 4 & 3 & 4 & 3 & 3 & \text{MIN} \\
 2: & 1 & 1 & 1 & 1 & & & & & & & = 1 \\
 3': & & & -1 & 1 & 1 & 1 & & & & & = 0 \\
 4': & & -1 & & & -1 & 1 & 1 & & & & = 0 \\
 5': & -1 & & & & -1 & & -1 & 1 & & & = 0
 \end{array}$$

This is a network LP, so it has a naturally integer solution.

Example

In trying to find the minimum elapsed time for a certain project composed of seven activities, the following LP was constructed (in PICTURE form):

$$\begin{array}{cccccc}
 & A & B & C & D & E & F \\
 1: & -1 & & & & & 1 \text{ MIN} \\
 AB: & -1 & 1 & & & & \geq 3 \\
 AC: & -1 & & 1 & & & \geq 2 \\
 BD: & & -1 & & 1 & & \geq 5 \\
 BE: & & -1 & & & 1 & \geq 6 \\
 CF: & & & -1 & & & 1 \geq 4 \\
 DF: & & & & -1 & & 1 \geq 7 \\
 EF: & & & & & -1 & 1 \geq 6
 \end{array}$$

This is neither a network LP (e.g., consider columns A , B , or F) nor an MRP LP (e.g., consider columns A or F). Nevertheless, when solved, we get the naturally integer solution:

Optimal solution found at step:		0
Objective value:		15.00000
Variable	Value	Reduced Cost
A	0.000000	0.000000
B	3.000000	0.000000
C	2.000000	0.000000
D	8.000000	0.000000
E	9.000000	0.000000
F	15.000000	0.000000
Row	Slack or Surplus	Dual Price
1	15.00000	1.000000
AB	0.000000	-1.000000
AC	0.000000	0.000000
BD	0.000000	-1.000000
BE	0.000000	0.000000
CF	9.000000	0.000000
DF	0.000000	-1.000000
EF	0.000000	0.000000

Could we have predicted a naturally integer solution beforehand? If we look at the PICTURE of the model, we see each constraint has exactly one +1 and one -1. Thus, its dual model is a network LP and expectation of integer answers is justified.

11.6 The Assignment Problem and Related Sequencing and Routing Problems

The assignment problem is a simple LP problem, which is frequently encountered as a major component in more complicated practical problems.

The assignment problem is:

Given a matrix of costs:

$$c_{ij} = \text{cost of assigning object } i \text{ to person } j,$$

and variables:

$$x_{ij} = 1 \text{ if object } i \text{ is assigned to person } j.$$

Then, we want to:

$$\text{Minimize } \sum_i \sum_j c_{ij} x_{ij}$$

subject to

$$\sum_j x_{ij} = 1 \text{ for each object } i,$$

$$\sum_i x_{ij} = 1 \text{ for each person } i,$$

$$x_{ij} \geq 0.$$

This problem is easy to solve as an LP and the x_{ij} will be naturally integer.

There are a number of problems in routing and sequencing that are closely related to the assignment problem.

11.6.1 Example: The Assignment Problem

Large airlines tend to base their route structure around the hub concept. An airline will try to have a large number of flights arrive at the hub airport during a certain short interval of time (e.g., 9 A.M. to 10 A.M.) and then have a large number of flights depart the hub shortly thereafter (e.g., 10 A.M. to 11 A.M.). This allows customers of that airline to travel between a large combination of origin/destination cities with one stop and at most one change of planes. For example, United Airlines uses Chicago as a hub, Delta Airlines uses Atlanta, and American uses Dallas/Fort Worth.

A desirable goal in using a hub structure is to minimize the amount of changing of planes (and the resulting moving of baggage) at the hub. The following little example illustrates how the assignment model applies to this problem.

A certain airline has six flights arriving at O'Hare airport between 9:00 and 9:30 A.M. The same six airplanes depart on different flights between 9:40 and 10:20 A.M. The average numbers of people transferring between incoming and leaving flights appear below:

	L01	L02	L03	L04	L05	L06	
I01	20	15	16	5	4	7	
I02	17	15	33	12	8	6	
I03	9	12	18	16	30	13	
I04	12	8	11	27	19	14	<i>Flight I05 arrives too late to</i>
I05	0	7	10	21	10	32	<i>connect with L01. Similarly I06 is</i>
I06	0	0	0	6	11	13	<i>too late for flights L01, L02, and L03.</i>

All the planes are identical. A decision problem is which incoming flight should be assigned to which outgoing flight. For example, if incoming flight *I02* is assigned to leaving flight *L03*, then 33 people (and their baggage) will be able to remain on their plane at the stop at O'Hare. How should incoming flights be assigned to leaving flights, so a minimum number of people need to change planes at the O'Hare stop?

This problem can be formulated as an assignment problem if we define:

$$x_{ij} = \begin{cases} 1 & \text{if incoming flight } i \text{ is assigned to outgoing flight } j, \\ 0 & \text{otherwise.} \end{cases}$$

The objective is to maximize the number of people not having to change planes. A formulation is:

```

MODEL:      ! Assignment model(ASSIGNMX);
SETS:
  FLIGHT;
  ASSIGN( FLIGHT, FLIGHT): X, CHANGE;
ENDSETS
DATA:
  FLIGHT = 1..6;
! The value of assigning i to j;
  CHANGE = 20  15  16  5  4  7
           17  15  33  12  8  6
           9  12  18  16  30  13
           12  8  11  27  19  14
          -999  7  10  21  10  32
          -999 -999 -999  6  11  13;
ENDDATA
!-----;
! Maximize value of assignments;
MAX = @SUM(ASSIGN: X * CHANGE);
@FOR( FLIGHT( I):
! Each I must be assigned to some J;
  @SUM( FLIGHT( J): X( I, J)) = 1;
! Each I must receive an assignment;
  @SUM( FLIGHT( J): X( J, I)) = 1;
);
END

```

Notice, we have made the connections that are impossible prohibitively unattractive. A solution is:

```

Optimal solution found at step:          9
Objective value:                      135.0000
Variable      Value      Reduced Cost
X( 1, 1)      1.000000      0.0000000
X( 2, 3)      1.000000      0.0000000
X( 3, 2)      1.000000      0.0000000
X( 4, 4)      1.000000      0.0000000
X( 5, 6)      1.000000      0.0000000
X( 6, 5)      1.000000      0.0000000

```

Notice, each incoming flight except *I03* is able to be assigned to its most attractive outgoing flight. The solution is naturally integer even though we did not declare any of the variables to be integer.

11.6.2 The Traveling Salesperson Problem

One of the more famous optimization problems is the traveling salesperson problem (TSP). It is an assignment problem with the additional condition that the assignments chosen must constitute a tour. The objective is to minimize the total distance traveled. Lawler et al. (1985) presents a tour-de-force on this fascinating problem. One example of a TSP occurs in the manufacture of electronic circuit boards. Danusaputro, Lee, and Martin-Vega (1990) discuss the problem of how to optimally sequence the drilling of holes in a circuit board, so the total time spent moving the drill head between holes is minimized. A similar TSP occurs in circuit board manufacturing in determining the sequence in which components should be inserted onto the board by an automatic insertion machine. Another example is the sequencing of cars on a production line for painting: each time there is a change in color, a setup cost and time is incurred.

A TSP is described by the data:

c_{ij} = cost of traveling directly from city i to city j , e.g., the distance.

A solution is described by the variables:

y_{ij} = 1 if we travel directly from i to j , else 0.

The objective is:

$$\text{Min } \sum_i \sum_j c_{ij} y_{ij};$$

We will describe several different ways of specifying the constraints.

Subtour Elimination Formulation:

- (1) We must enter each city j exactly once:

$$\sum_{i \neq j}^n y_{ij} = 1 \quad \text{for } j = 1 \text{ to } n,$$

- (2) We must exit each city i exactly once:

$$\sum_{j \neq i}^n y_{ij} = 1 \quad \text{for } i = 1 \text{ to } n,$$

- (3) $y_{ij} = 0$ or 1, for $i = 1, 2, \dots, n$, $j = 1, 2, \dots, n$, $i \neq j$:

- (4) No subtours are allowed for any subset of cities S not including city 1:

$$\sum_{i,j \in S} y_{ij} \leq |S| - 1 \quad \text{for every subset } S,$$

where $|S|$ is the size of S .

The above formulation is usually attributed to Dantzig, Fulkerson, and Johnson(1954). An unattractive feature of the Subtour Elimination formulation is that if there are n cities, then there are approximately 2^n constraints.

Cumulative Load Formulation:

We can reduce the number of constraints substantially if we define: u_j = the sequence number of city j on the trip. Equivalently, if each city requires one unit of something to be picked up(or delivered), then u_j = cumulative number of units picked up(or delivered) after the stop at j . We replace constraint set (4) by:

$$(5) \quad u_j \geq u_i + 1 - (1 - y_{ij})n \quad \text{for } i = 1, 2, \dots, j = 2, 3, 4, \dots; j \neq i.$$

The approach of constraint set (5) is due to Miller, Tucker, and Zemlin(1960). There are only approximately n^2 constraints of type (5), however, constraint set (4) is much tighter than (5). Large problems may be computationally intractable if (4) is not used. Even though there are a huge number of constraints in (4), only a few of them may be binding at the optimum. Thus, an iterative approach that adds violated constraints of type (4) as needed works surprisingly well. Padberg and Rinaldi (1987) used essentially this iterative approach and were able to solve to optimality problems with over 2000 cities. The solution time was several hours on a large computer.

Multi-commodity Flow Formulation:

Similar to the previous formulation, imagine that each city needs one unit of some commodity distinct to that city. Define:

$$x_{ijk} = \text{units of commodity carried from } i \text{ to } j, \text{ destined for ultimate delivery to } k.$$

If we assume that we start at city 1 and there are n cities, then we replace constraint set (4) by:

For $k = 1, 2, 3, \dots, n$:

$$\sum_{j>1} x_{1jk} = 1; \quad (\text{Each unit must be shipped out of the origin.})$$

$$\sum_{i \neq k} x_{ikk} = 1; \quad (\text{Each city } k \text{ must get its unit.})$$

For $j = 2, 3, \dots, n, k=1, 2, 3, \dots, n, j \neq k$:

$$\sum_i x_{ijk} = \sum_{t \neq j} x_{jtk} \quad (\text{Units entering } j, \text{ but not destined for } j, \text{ must depart } j \text{ to some city } t.)$$

A unit cannot return to 1, except if its final destination is 1:

$$\sum_i \sum_{k>1} x_{i1k} = 0,$$

For $i = 1, 2, \dots, n, j = 1, 2, \dots, n, k = 1, 2, \dots, n, i \neq j$:

$$x_{ijk} \leq y_{ij} \quad (\text{If anything shipped from } i \text{ to } j, \text{ then turn on } y_{ij}.)$$

The drawback of this formulation is that it has approximately n^3 constraints and variables. A remarkable feature of the multicommodity flow formulation is that it is just as tight as the Subtour Elimination formulation. The multi-commodity formulation is due to Claus(1984).

Heuristics

For practical problems, it may be important to get good, but not necessarily optimal, answers in just a few seconds or minutes rather than hours. The most commonly used heuristic for the TSP is due to Lin and Kernighan (1973). This heuristic tries to improve a given solution by clever re-orderings of cities in the tour. For practical problems (e.g., in operation sequencing on computer controlled machines), the heuristic seems always to find solutions no more than 2% more costly than the optimum. Bland and Shallcross (1989) describe problems with up to 14,464 "cities" arising from the sequencing of operations on a computer controlled machine. In no case was the Lin-Kernighan heuristic more than 1.7% from the optimal for these problems.

Example of a Traveling Salesperson Problem

P. Rose, currently unemployed, has hit upon the following scheme for making some money. He will guide a group of 18 people on a tour of all the baseball parks in the National League. He is betting his life savings on this scheme, so he wants to keep the cost of the tour as low as possible. The tour will start and end in Cincinnati. The following distance matrix has been constructed:

	Atl	Chi	Cin	Hou	LA	Mon	NY	Phi	Pit	StL	SD	SF
Atlanta	0	702	454	842	2396	1196	864	772	714	554	2363	2679
Chicago	702	0	324	1093	2136	764	845	764	459	294	2184	2187
Cinci.	454	324	0	1137	2180	798	664	572	284	338	2228	2463
Houston	842	1093	1137	0	1616	1857	1706	1614	1421	799	1521	2021
L.A.	2396	2136	2180	1616	0	2900	2844	2752	2464	1842	95	405
Montreal	1196	764	798	1857	2900	0	396	424	514	1058	2948	2951
New York	864	845	664	1706	2844	396	0	92	386	1002	2892	3032
Phildpha.	772	764	572	1614	2752	424	92	0	305	910	2800	2951
Pittsbrg.	714	459	284	1421	2464	514	386	305	0	622	2512	2646
St. Louis	554	294	338	799	1842	1058	1002	910	622	0	1890	2125
San Diego	2363	2184	2228	1521	95	2948	2892	2800	2512	1890	0	500
San Fran.	2679	2187	2463	2021	405	2951	3032	2951	2646	2125	500	0

Solution

We will illustrate the subtour elimination approach, exploiting the fact that the distance matrix is symmetric. Define the decision variables:

$Y_{ij} = 1$ if the link between cities i and j is used, regardless of the direction of travel; 0 otherwise.

Thus, $Y_{ATLCHI} = 1$ if the link between Atlanta and Chicago is used. Each city or node must be connected to two links. In words, the formulation is:

Minimize the cost of links selected

subject to:

For each city, the number of links connected to it that are selected = 2

Each link can be selected at most once.

The LINGO formulation is shown below:

```

MODEL:
SETS:
  CITY;
  ROUTE(CITY, CITY)|&1 #GT# &2:COST, Y;
ENDSETS
DATA:
  CITY=
    ATL  CHI  CIN  HOU  LA  MON  NY  PHI  PIT  STL  SD  SF;
  COST=
    702
    454  324
    842 1093 1137
    2396 2136 2180 1616
    1196 764 798 1857 2900
    864 845 664 1706 2844 396
    772 764 572 1614 2752 424 92
    714 459 284 1421 2464 514 386 305
    554 294 338 799 1842 1058 1002 910 622
    2363 2184 2228 1521 95 2948 2892 2800 2512 1890
    2679 2187 2463 2021 405 2951 3032 2951 2646 2125 500;
ENDDATA
MIN = @SUM( ROUTE: Y * COST);
@SUM( CITY( I)|I #GE# 2: Y(I, 1)) = 2;
@FOR( CITY( J)|J #GE# 2: @SUM(CITY(I)| I #GT# J:
  Y(I, J)) + @SUM(CITY(K)|K #LT# J: Y(J, K))=2);
@FOR( ROUTE: Y <= 1);
END

```

When this model is solved *as an LP*, we get the solution:

```

Optimal solution found at step:      105
Objective value:                    5020.000

```

Variable	Value	Reduced Cost
Y(CIN, ATL)	1.000000	0.0000000
Y(CIN, CHI)	1.000000	0.0000000
Y(HOU, ATL)	1.000000	0.0000000
Y(NY, MON)	1.000000	0.0000000
Y(PHI, NY)	1.000000	0.0000000
Y(PIT, MON)	1.000000	0.0000000
Y(PIT, PHI)	1.000000	0.0000000
Y(STL, CHI)	1.000000	0.0000000
Y(STL, HOU)	1.000000	0.0000000
Y(SD, LA)	1.000000	0.0000000
Y(SF, LA)	1.000000	0.0000000
Y(SF, SD)	1.000000	0.0000000

This has a cost of 5020 miles. Graphically, it corresponds to Figure 11.6.

Figure 11.6

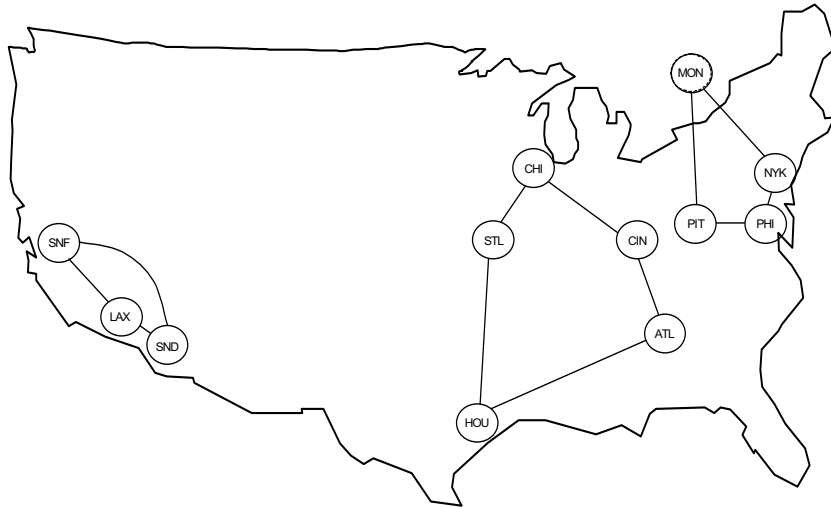

Unfortunately, the solution has three subtours. We can cut off the smallest subtour by adding the constraint:

```
!SUBTOUR ELIMINATION;
Y( SF, LA) + Y( SD, LA) + Y( SF, SD) <= 2;
```

Now, when we solve it *as an LP*, we get a solution with cost 6975, corresponding to Figure 11.7:

Figure 11.7

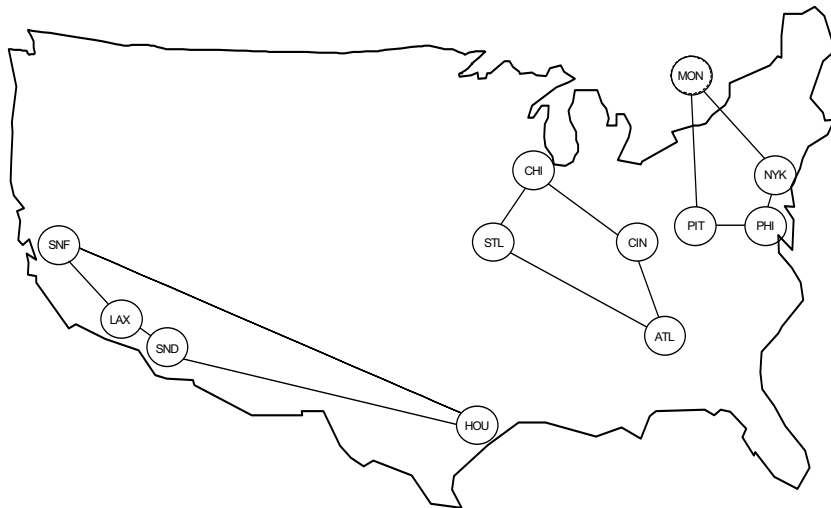

We cut off the subtour in the southwest by appending the constraint:

$$Y(LA, HOU) + Y(SD, HOU) + Y(SF, LA) + Y(SF, SD) \leq 3;$$

We continue in this fashion appending subtour elimination cuts:

$$\begin{aligned} Y(CIN, ATL) + Y(CIN, ATL) + Y(CIN, CHI) + Y(HOU, ATL) + Y(STL, CHI) + \\ Y(STL, HOU) &\leq 4; \\ Y(NY, MON) + Y(PHI, NY) + Y(PIT, MON) + Y(PIT, PHI) &\leq 3; \\ Y(SD, LA) + Y(SF, LA) + Y(SF, SD) &\leq 2; \\ Y(NY, MON) + Y(PHI, MON) + Y(PHI, NY) &\leq 2; \\ Y(CIN, ATL) + Y(PIT, CHI) + Y(PIT, CIN) + Y(STL, ATL) + Y(STL, CHI) &\leq 4; \\ Y(SD, HOU) + Y(SD, LA) + Y(SF, HOU) + Y(SF, LA) &\leq 3; \\ Y(CIN, ATL) + Y(CIN, CHI) + Y(STL, ATL) + Y(STL, CHI) &\leq 3; \\ Y(PHI, MON) + Y(PHI, NY) + Y(PIT, MON) + Y(PIT, NY) &\leq 3; \\ Y(CIN, ATL) + Y(MON, CHI) + Y(NY, MON) + Y(PHI, NY) + Y(PIT, CIN) + \\ PIT, PHI) + Y(STL, ATL) + Y(STL, CHI) &\leq 7; \\ Y(SD, LA) + Y(SF, HOU) + Y(SF, SD) + Y(LA, HOU) &\leq 3; \end{aligned}$$

After the above are all appended, we get the solution shown in Figure 11.8. It is a complete tour with cost \$7,577.

Figure 11.8

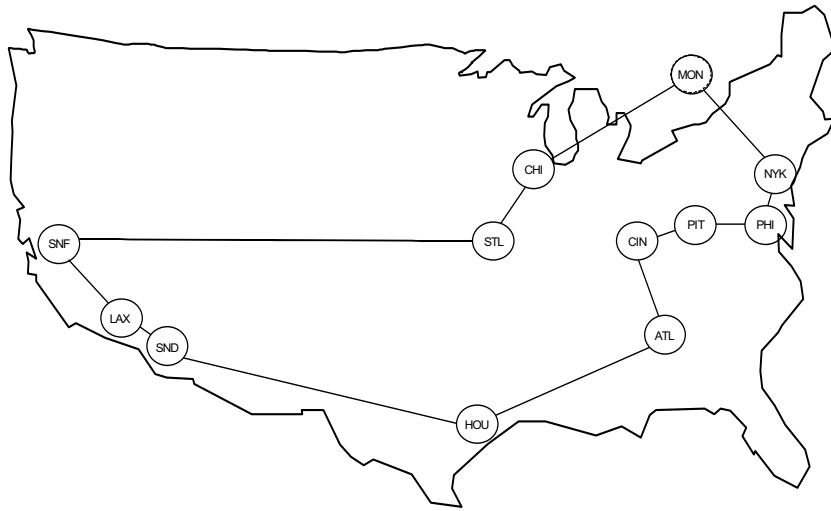

Note only LPs were solved. No branch-and-bound was required, although in general branching may be required.

Could P. Rose have done as well by trial and error? The most obvious heuristic is the “closest unvisited city” heuristic. If one starts in Cincinnati and next goes to the closest unvisited city at each step and finally returns to Cincinnati, the total distance is 8015 miles, about 6% worse than the optimum.

The Optional Stop TSP

If we drop the requirement that every stop must be visited, we then get the optional stop TSP. This might correspond to a job sequencing problem where v_j is the profit from job j if we do it and c_{ij} is the cost of switching from job i to job j . Let:

$$y_j = 1 \text{ if city } j \text{ is visited, } 0 \text{ otherwise.}$$

If v_j is the value of visiting city j , then the objective is:

$$\text{Minimize } \sum_i \sum_j c_{ij} x_{ij} - \sum_j v_j y_j.$$

The constraint sets are:

- (1) Each city j can be visited at most once

$$\sum_{i \neq j} x_{ij} = y_j$$

- (2) If we enter city j , then we must exit it:

$$\sum_{k \neq j} x_{jk} = y_j$$

- (3) No subtours allowed for each subset, S , of cities not including the home base 1.

$$\sum_{i, j \in S} x_{ij} \leq |S| - 1, \text{ where } |S| \text{ is the size of } S.$$

For example, if there are n cities, including the home base, then there are $(n-1)(n-2)/(3 \times 2)$ subsets of size 3.

- (4) Alternatively, (3) may be replaced by

$$u_j \geq u_i + 1 - (1 - x_{ij})n \quad \text{for } j = 2, 3, \dots, n.$$

Effectively, u_j is the sequence number of city j in its tour. Constraint set (3) is much tighter than (4).

11.6.3 Capacitated Multiple TSP/Vehicle Routing Problems

An important practical problem is the routing of vehicles from a central depot. An example is the routing of delivery trucks for a metropolitan newspaper. You can think of this as a multiple traveling salesperson problem with finite capacity for each salesperson. This problem is sometimes called the LTL (Less than TruckLoad) routing problem because a typical recipient receives less than a truck load of goods. A formulation is:

Given:

V = capacity of a vehicle

d_j = demand of city or stop j

Each city, j , must be visited once for $j > 1$:

$$\sum_j x_{ij} = 1$$

Each city $i > 1$, must be exited once:

$$\sum_i x_{ij} = 1$$

No subtours:

$$\sum_{i,j \in S} x_{ij} \leq |S| - 1,$$

No overloads: For each set of cities T , including 1, which constitute more than a truckload:

$$\sum_{i,j \in T} x_{ij} \leq |T| - k,$$

where k = minimum number of cities that must be dropped from T to reduce it to one load.

This formulation can solve to optimality modest-sized problems of say, 25 cities. For larger or more complicated practical problems, the heuristic method of Clarke and Wright (1964) is a standard starting point for quickly finding good, but not necessarily optimal, solutions.

The following is a generic LINGO model for vehicle routing problems:

```

MODEL:      ! (VROUTE);
! The Vehicle Routing Problem (VRP) occurs in many service
systems such as delivery, customer pick-up, repair and
maintenance. A fleet of vehicles, each with fixed
capacity, starts at a common depot and returns to the
depot after visiting locations where service is demanded.
Problems with more than a dozen cities can take lots of
time.
This instance involves delivering the required amount of
goods to 9 cities from a depot at city 1;
SETS:
  CITY/ Chi Den Frsn Hous KC LA Oakl Anah Peor Phnx/: Q, U;
  ! Q(I) = amount required at city I(given),
  ! must be delivered by just 1 vehicle.
  U(I) = accumulated deliveries at city I ;
  CXC( CITY, CITY): DIST, X;
  ! DIST(I,J) = distance from city I to city J
  ! X(I,J) is 0-1 variable,
  ! = 1 if some vehicle travels from city I to J,
  ! else 0 ;
ENDSETS
DATA:
  ! city 1 represents the common depot, i.e. Q( 1) = 0;
Q= 0   6   3   7   7   18   4   5   2   6;

```



```

! distance from city I to city J is same from J to I,
distance from city I to the depot is 0,
because vehicle need not return to the depot ;
DIST= ! To City;
!Chi Den Frsn Hous KC LA Oakl Anah Peor Phnx From;
0 996 2162 1067 499 2054 2134 2050 151 1713! Chicago;
0 0 1167 1019 596 1059 1227 1055 904 792! Denver;
0 1167 0 1747 1723 214 168 250 2070 598! Fresno;
0 1019 1747 0 710 1538 1904 1528 948 1149! Houston;
0 596 1723 710 0 1589 1827 1579 354 1214! K. City;
0 1059 214 1538 1589 0 371 36 1943 389! L. A.;
0 1227 168 1904 1827 371 0 407 2043 755! Oakland;
0 1055 250 1528 1579 36 407 0 1933 379! Anaheim;
0 904 2070 948 354 1943 2043 1933 0 1568! Peoria;
0 792 598 1149 1214 389 755 379 1568 0;! Phoenix;
! VCAP is the capacity of a vehicle ;
VCAP = 18;
ENDDATA
!-----;
! The objective is to minimize total travel distance;
MIN = @SUM( CXC: DIST * X);
! for each city, except depot....;
@FOR( CITY( K)| K #GT# 1:
! a vehicle does not travel inside itself,...;
X( K, K) = 0;
! a vehicle must enter it,... ;
@SUM( CITY( I)| I #NE# K #AND# ( I #EQ# 1 #OR#
Q( I) + Q( K) #LE# VCAP): X( I, K)) = 1;
! a vehicle must leave it after service ;
@SUM( CITY( J)| J #NE# K #AND# ( J #EQ# 1 #OR#
Q( J) + Q( K) #LE# VCAP): X( K, J)) = 1;
! U( K) = amount delivered on trip up to city K
>= amount needed at K but <= vehicle capacity;
@BND( Q( K), U( K), VCAP);
! If K follows I, then can bound U( K) - U( I);
@FOR( CITY( I)| I #NE# K #AND# I #NE# 1: U( K) >=
U( I) + Q( K) - VCAP + VCAP*( X( K, I) + X( I, K))
- ( Q( K) + Q( I) ) * X( K, I);
);
! If K is 1st stop, then U( K) = Q( K);
U( K) <= VCAP - ( VCAP - Q( K) ) * X( 1, K);
! If K is not 1st stop...;
U( K) >=
Q( K) + @SUM( CITY( I)| I #GT# 1: Q( I) * X( I, K));
);
! Make the X's binary;
@FOR( CXC( I, J): @BIN( X( I, J) ););
! Must send enough vehicles out of depot;
@SUM( CITY( J)| J #GT# 1: X( 1, J) ) >=
@FLOOR((@SUM( CITY( I)| I #GT# 1: Q( I))/ VCAP) + .999);
END

```

```

Optimal solution found at step:      973
Objective value:                      6732.000

      Variable      Value
X( CHI, HOUS)      1.000000
X( CHI, LA)        1.000000
X( CHI, PEOR)      1.000000
X( CHI, PHNX)      1.000000
X( DEN, CHI)       1.000000
X( FRSN, OAKL)     1.000000
X( HOUS, CHI)      1.000000
X( KC, DEN)        1.000000
X( LA, CHI)        1.000000
X( OAKL, CHI)      1.000000
X( ANAH, FRSN)     1.000000
X( PEOR, KC)       1.000000
X( PHNX, ANAH)    1.000000

```

By following the links, you can observe that the trips are:

Chicago - Houston;
 Chicago - LA;
 Chicago - Peoria - KC - Denver;
 Chicago - Phoenix - Anaheim - Fresno - Oakland.

Combined DC Location/Vehicle Routing

Frequently, there is a vehicle routing problem associated with opening a new plant or distribution center (DC). Specifically, given the customers to be served from the DC, what trips are made, so as to serve the customers at minimum cost. A “complete” solution to the problem would solve the location and routing problems simultaneously. The following IP formulation illustrates one approach:

Parameters

F_i = fixed cost of having a DC at location i ,
 C_j = cost of using route j ,
 $a_{ijk} = 1$ if route j originates at DC i and serves customer k . There is exactly one DC associated with each route.

Decision variables

$y_i = 1$ if we use DC i , else 0,
 $x_j = 1$ if we use route j , else 0

The Model

$$\text{Minimize } \sum_i F_i y_i + \sum_j c_j x_j$$

subject to

(Demand constraints)

For each customer k :

$$\sum_i \sum_j a_{ijk} x_j = 1$$

(Forcing constraints)

For each DC i and customer k :

$$\sum_j a_{ijk} x_j \leq y_i$$

11.6.4 Minimum Spanning Tree

A spanning tree of n nodes is a collection of $n - 1$ arcs, so there is exactly one path between every pair of nodes. A minimum cost spanning tree might be of interest, for example, in designing a communications network.

Assume node 1 is the root of the tree. Let $x_{ij} = 1$ if the path from 1 to j goes through node i immediately before node j , else $x_{ij} = 0$.

A formulation is:

$$\text{Minimize } \sum_i \sum_j c_{ij} x_{ij}$$

subject to

$$(1) \sum_i \sum_j x_{ij} = n - 1,$$

$$(2) \sum_{i,j \in S} x_{ij} \leq |S| - 1 \text{ for every strict subset } S \text{ of } \{1, 2, \dots, n\},$$

$$x_{ij} = 0 \text{ or } 1.$$

An alternative to (1) and (2) is the following set of constraints based on assigning a unique sequence number u_j to each node:

$$\sum_{i \neq j} x_{ij} = 1, \text{ for } j = 2, 3, 4, \dots, n,$$

$$u_j \geq u_i + x_{ij} - (n-2)(1-x_{ij}) + (n-3)x_{ji}, \text{ for } j = 2, 3, 4, \dots, n,$$

$$u_j \geq 0.$$

In this case, u_j is the number of arcs between node j and node 1. A numeric example of the sequence numbering formulation is in section 8.9.8.

If one has a pure spanning tree problem, then the “greedy” algorithm of Kruskal (1956) is a fast way of finding optimal solutions.

11.6.5 The Linear Ordering Problem

A problem superficially similar to the TSP is the linear ordering problem. One wants to find a strict ordering of n objects. Applications are to ranking in sports tournaments, product preference ordering in marketing, job sequencing on one machine, ordering of industries in an input-output matrix, ordering of historical objects in archeology, and others. See Grötschel et al. (1985) for a further discussion. The linear ordering problem is similar to the approach of conjoint analysis sometimes used in marketing. The crucial input data are cost entries c_{ij} . If object i appears *anywhere* before object j in the proposed ordering, then c_{ij} is the resulting cost. The decision variables are:

$$x_{ij} = 1 \text{ if object } i \text{ precedes object } j, \text{ either directly or indirectly for all } i \neq j.$$

The problem is:

$$\text{Minimize } \sum_i \sum_j c_{ij} x_{ij}$$

subject to

$$(1) x_{ij} + x_{ji} = 1 \text{ for all } i \neq j$$

If i precedes j and j precedes k , then we want to imply that i precedes k . This is enforced with the constraints:

$$(2) x_{ij} + x_{jk} + x_{ki} \leq 2 \text{ for all } i, j, k \text{ with } i \neq j, i \neq k, j \neq k.$$

The size of the formulation can be cut in two by noting that $x_{ij} = 1 - x_{ji}$. Thus, we substitute out x_{ji} for $j > i$. Constraint set (1) becomes simply $0 \leq x_{ij} \leq 1$. Constraint set (2) becomes:

$$(2') x_{ij} + x_{jk} - x_{ik} + s_{ijk} = 1 \text{ for all } i < j < k \\ 0 \leq s_{ijk} \leq 1$$

There are $n!/((n-3)!3!) = n \times (n-1) \times (n-2)/6$ ways of choosing 3 objects from n , so the number of constraints is approximately $n^3/6$.

Example

Ten Czech, German, and North American beverages were subject to taste tests by unbiased German testers. Each of the $10 \times 9/2 = 45$ possible pairs was subject to a taste test by six judges. The element $C(I, J)$ in the C matrix in the model below is the number of times out of six beverage I was preferred to beverage J . If we want to have a complete ranking for the beverages, a reasonable objective is to maximize the number of pairwise comparisons for which our ranking agrees with the pairwise ranking of the judges:

```

MODEL:
! Linear ordering of objects or products,
  based on pairwise comparisons(LINERORD);
SETS:
  PROD: RANK; ! Each product will get a rank;
  PXP( PROD, PROD): C;
ENDSETS
DATA:
  PROD = KONIG, FURST, PILSURQ, GUNZB, RIEGELE,
        PAULA, JEVER, BECKS, WARST, BUD;
! Some data on German beverages;
  C= ! Times that object I was preferred over J;
0   2   2   3   3   5   5   5   4   4
4   0   3   3   4   3   2   3   2   2
4   3   0   3   5   4   3   2   4   4
3   3   3   0   5   6   3   4   4   3
3   2   1   1   0   1   4   4   5   3
1   3   2   0   5   0   5   4   1   4
1   4   3   3   2   1   0   2   1   3
1   3   4   2   2   2   4   0   4   2
2   4   2   2   1   5   5   2   0   4
2   4   2   3   3   2   3   4   2   0;
ENDDATA
!-----;
SETS:
  PIP( PROD, PROD) | &1 #LT# &2:
    X; ! X(I,J) = 1 if I precedes J in our ranking;
  PIIPI( PROD, PROD)
    | &1 #LT# &2 #AND# &2 #LT# &3: S;
ENDSETS

```

```

! Maximize the number of times our pairwise
  ordering matches that of our testers;
MAX =
@SUM( PIP( I, J): C( I, J) * X( I, J)
      + C( J, I) *(1 - X( I, J)));
! The rankings must be transitive, that is,
  If I->J and J->K, then I->K;
@FOR( PIP( I, J, K):
!   Note N*(N-1)*(N-2)/6 of these!;
X( I, J) + X( J, K) - X( I, K)
      + S( I, J, K) = 1;
      @BND( 0, S( I, J, K), 1);
      );
@FOR( PIP: @BIN( X);); ! Make X's 0 or 1;

! Count number products before product I( + 1);
@FOR( PROD( I):
RANK( I) = 1 + @SUM( PIP( K, I): X( K, I))
      + @SUM( PIP( I, K): 1 - X( I, K));
      );
END

```

When solved, we get an optimal objective value of 168. This means out of the $(10 * 9/2) * 6 = 270$ pairwise comparisons, the pairwise rankings agreed with LINGO's complete ranking 168 times:

```

Optimal solution found at step:      50
Objective value:                     168.0000
Branch count:                        0

```

Variable	Value	Reduced Cost
RANK(KONIG)	3.000000	0.0000000
RANK(FURST)	10.000000	0.0000000
RANK(PILSURQ)	2.000000	0.0000000
RANK(GUNZB)	1.000000	0.0000000
RANK(RIEGELE)	7.000000	0.0000000
RANK(PAULA)	5.000000	0.0000000
RANK(JEVER)	9.000000	0.0000000
RANK(BECKS)	8.000000	0.0000000
RANK(WARST)	4.000000	0.0000000
RANK(BUD)	6.000000	0.0000000

According to this ranking, *GUNZB* comes out number 1 (most preferred), while *FURST* comes out tenth (least preferred). It is important to note that there may be alternate optima. This means there may be alternate orderings, all of which match the input pairings 168 times out of 270. In fact, you can show that there is another ordering with a value of 168 in which *PILSURQ* is ranked first.

11.6.6 Quadratic Assignment Problem

The quadratic assignment problem has the same constraint set as the linear assignment problem. However, the objective function contains products of two variables. Notationally, it is:

$$\text{Min } \sum_i \sum_j \sum_k \sum_l c_{ijkl} x_{ij} x_{kl}$$

subject to:

For each j :

$$\sum_i x_{ij} = 1$$

For each i :

$$\sum_j x_{ij} = 1$$

Some examples of this problem are:

- (a) *Facility layout.* If d_{jl} is the physical distance between room j and room l ; s_{ik} is the communication traffic between department i and k ; and $x_{ij} = 1$ if department i is assigned to room j , then we want to minimize:

$$\sum_i \sum_j \sum_k \sum_l x_{ij} x_{kl} d_{jl} s_{ik}$$

- (b) *Vehicle to gate assignment at a terminal.* If d_{jl} is the distance between gate j and gate l at an airline terminal, passenger train station, or at a truck terminal; s_{ik} is the number of passengers or tons of cargo that needs to be transferred between vehicle i and vehicle k ; and $x_{ij} = 1$ if vehicle i (incoming or outgoing) is assigned to gate j , then we again want to minimize:

$$\sum_i \sum_j \sum_k \sum_l x_{ij} x_{kl} d_{jl} s_{ik}$$

- (c) *Radio frequency assignment.* If d_{ij} is the physical distance between transmitters i and j ; s_{kl} is the distance in frequency between k and l ; and p_i is the power of transmitter i , then we want $\max\{p_i, p_j\} (1/d_{ij})(1/s_{kl})$ to be small if transmitter i is assigned frequency k and transmitter j is assigned frequency l .
- (d) *VLSI chip layout.* The initial step in the design of a VLSI (very large scale integrated) chip is typically to assign various required components to various areas on the chip. See Sarrafzadeh and Wong (1996) for additional details. Steinberg (1961) describes the case of assigning electronic components to a circuit board, so as to minimize the total interconnection wire length. For the chip design case, typically the chip area is partitioned into 2 to 6 areas. If d_{jl} is the physical distance between area j and area l ; s_{ik} is the number of connections required between components i and k ; and $x_{ij} = 1$ if component i is assigned to area j , then we again want to minimize:

$$\sum_i \sum_j \sum_k \sum_l x_{ij} x_{kl} d_{jl} s_{ik}$$

- (e) *Disk file allocation.* If w_{ij} is the interference if files i and j are assigned to the same disk, we want to assign files to disks, so total interference is minimized.

- (f) *Type wheel design.* Arrange letters and numbers on a type wheel, so (a) most frequently used ones appear together and (b) characters that tend to get typed together (e.g., q u) appear close together on the wheel.

The quadratic assignment problem is a notoriously difficult problem. If someone asks you to solve such a problem, you should make every effort to show the problem is not really a quadratic assignment problem. One indication of its difficulty is the solution is not naturally integer.

One of the first descriptions of quadratic assignment problems was by Koopmans and Beckmann (1957). For this reason, this problem is sometimes known as the Koopmans-Beckmann problem. They illustrated the use of this model to locate interacting facilities in a large country. Elshafei (1977) illustrates the use of this model to lay out a hospital. Specifically, 19 departments are assigned to 19 different physical regions in the hospital. The objective of Elshafei was to minimize the total distance patients had to walk between departments. The original assignment used in the hospital required a distance of 13,973,298 meters per year. An optimal assignment required a total distance of 8,606,274 meters. This is a reduction in patient travel of over 38%.

Small quadratic assignment problems can be converted to linear integer programs by the transformation:

Replace the product $x_{ij} x_{kl}$ by the single variable z_{ijkl} . The objective is then:

$$\text{Min} \quad \sum_i \sum_j \sum_k \sum_l c_{ijkl} z_{ijkl}$$

Notice if there are N departments and N locations, then there are $N \times N$ variables of type x_{ij} , and $N \times N \times N \times N$ variables of type z_{ijkl} variables. This formulation can get large quickly. Several reductions are possible:

- 1) The terms $c_{ijkl} x_{ij} x_{kl}$ and $c_{klij} x_{kl} x_{ij}$ can be combined into the term:

$$(c_{ijkl} + c_{klij}) x_{kl} x_{ij}$$

to reduce the number of z variables and associated constraints needed by a factor of 2.

- 2) Certain assignments can be eliminated beforehand (e.g., a large facility to a small location). Many of the cross terms, c_{ijkl} , are zero (e.g., if there is no traffic between facility i and facility k), so the associated z variables need not be introduced.

The non-obvious thing to do now is to ensure that $z_{ijkl} = 1$ if and only if both $x_{ij} = 1$ and $x_{kl} = 1$. Sherali and Adams (1999) point out that constraints of the following type will enforce this requirement:

For a given i, k, l :

$$x_{kl} = \sum_{j, j \neq l} z_{ijkl}$$

In words, if object k is assigned to location l , then for any other object $i, i \neq k$, there must be some other location $j, j \neq l$, to which i is assigned.

The following is a LINGO implementation of the above for deciding which planes should be assigned to which gates at an airport, so that the distance weighted cost of changing planes for the passengers is minimized:

```

MODEL:
! Quadratic assignment problem(QAP006);
! Given number of transfers between flights,
  distance between gates,
  assign flights to gates to minimize total transfer cost;
SETS:
  FLIGHT/1..6/;
  GATE/ E3 E4 E5 F3 F4 F5/;! Gates at terminal 2 of O'Hare;
  GXG( GATE, GATE)| &1 #LT# &2: T; ! Inter gate times(symmetrical);
  FXF( FLIGHT, FLIGHT)| &1 #LT# &2: N; ! Transfers between flights;
  FXG( FLIGHT, GATE): X; ! Flight to gate assignment variable;
ENDSETS
DATA:
  T = 70 40 60 90 90 ! Time between gates;
      50 100 80 110
      100 90 130
      60 40
      30;
  N = 12 0 12 0 5
      30 35 20 13 ! No. units between flights;
      40 20 10
      0 6
      14;
ENDDATA
!-----;
! Warning: may be very slow for no. objects > 7;
SETS: ! Warning: this set gets big fast!;
  TGTG( FLIGHT, GATE, FLIGHT, GATE)| &1 #LT# &3: Z;
ENDSETS
! Min the cost of transfers * distance;
  MIN = @SUM( TGTG( B, J, C, K)| J #LT# K:
    Z( B, J, C, K) * N( B, C) * T( J, K))
    + @SUM( TGTG( B, J, C, K)| J #GT# K:
    Z( B, J, C, K) * N( B, C) * T( K, J));
! Each flight, B, must be assigned to a gate;
  @FOR( FLIGHT( B):
    @SUM( GATE( J): X( B, J)) = 1;
  );
! Each gate, J, must receive one flight;
  @FOR( GATE( J):
    @SUM( FLIGHT( B): X( B, J)) = 1;
  );
! Make the X's binary;
  @FOR( FXG: @BIN( X);
  );

```



```

! Force the Z() to take the correct value relative to the X();
@FOR( FXG( C, K):
  @FOR( GATE( J) | J #NE# K:
! If C is assigned to K, some B must be assigned to J...;
  X( C, K) = @SUM( TGTG( B, J, C, K) | B #NE# C : Z( B, J, C, K))
    + @SUM( TGTG( C, K, B, J) | B #NE# C : Z( C, K, B, J));
  );
  @FOR( FLIGHT( B) | B #NE# C:
! and B must be assigned to some J;
  X( C, K) = @SUM( TGTG( B, J, C, K) | J #NE# K : Z( B, J, C, K))
    + @SUM( TGTG( C, K, B, J) | J #NE# K : Z( C, K, B, J));
  );
);
END

```

The solution is:

```

Global optimal solution found at step:          1258
Objective value:                             13490.00
Branch count:                                 0

```

Variable	Value
X(1, E4)	1.000000
X(2, F4)	1.000000
X(3, F3)	1.000000
X(4, F5)	1.000000
X(5, E3)	1.000000
X(6, E5)	1.000000

Thus, flight 1 should be assigned to gate *E4*, flight 2 to gate *F4*, etc. The total passenger travel time in making the connections will be 13,490. Notice that this formulation was fairly tight. No branches were required to get an integer solution from the LP solution.

11.7 Problems of Grouping, Matching, Covering, Partitioning, and Packing

There is a class of problems that have the following essential structure:

- 1) There is a set of m objects, and
- 2) They are to be grouped into subsets, so some criterion is optimized.

Some example situations are:

Objects	Group	Criteria for a Group
(i) Dormitory inhabitants	Roommates	At most two to a room; no smokers with nonsmokers.
(ii) Deliveries to customers	Trip	Total weight assigned to trip is less-than-or-equal-to vehicle capacity. Customers in same trip are close together.
(iii) Sessions at a scientific meeting	Sessions scheduled for same time slot	No two sessions on same general topic. Enough rooms of sufficient size.
(iv) Exams to be scheduled	Exams scheduled for same time slot	No student has more than one exam in a given time slot.
(v) Sportsmen	Foursome (e.g., in golf or tennis doubles).	Members are of comparable ability, appropriate combination of sexes as in tennis mixed doubles.
(vi) States on map to be colored.	All states of a given color	States in same group/color cannot be adjacent.
(vii) Finished good widths needed in a paper plant	Widths cut from a single raw paper roll.	Sum of finished good widths must not exceed raw material width.
(viii) Pairs of points to connect on a circuit board	Connection layers underneath the circuit board	Connection paths in a layer should not intersect. Total lengths of paths are small.

If each object can belong to at most one group, it is called a *packing* problem. For example, in a delivery problem, as in (ii) above, it may be acceptable that a low priority customer not be included in any trip today if we are confident the customer could be almost as well served by a delivery tomorrow. If each object must belong to exactly one group, it is called a *partitioning* problem. For example, in circuit board routing as in (viii) above, if a certain pair of points must be connected, then that pair of points must be assigned to exactly one connection layer underneath the board. If each object must belong to at least one group, it is called a *covering* problem. A packing or partitioning problem with group sizes limited to two or less is called a *matching* problem. Specialized and fast algorithms exist for matching problems. A problem closely related to covering problems is the cutting stock problem. It arises in paper, printing, textile, and steel industries. In this problem, we want to determine cutting patterns to be used in cutting up large pieces of raw material into finished-good-size pieces.

Although grouping problems may be very easy to state, it may be very difficult to find a provably optimal solution if we take an inappropriate approach. There are two common approaches to formulating grouping problems: (1) assignment style, or (2) the partition method. The former is convenient for small problems, but it quickly becomes useless as the number of objects gets large.

11.7.1 Formulation as an Assignment Problem

The most obvious formulation for the general grouping problem is based around the following definition 0/1 decision variables:

$$X_{ij} = 1 \text{ if object } j \text{ is assigned to group } i, 0 \text{ otherwise.}$$

A drawback of this formulation is that it has a lot of symmetry. There are many alternate optimal solutions. All of which essentially are identical. For example, assigning golfers A, B, C , and D to group 1 and golfers E, F, G , and H to group 2 is essentially the same as assigning golfers E, F, G , and H to group 1 and golfers A, B, C and D to group 2. These alternate optima make the typical integer programming algorithm take much longer than necessary.

We can eliminate this symmetry and the associated alternate optima with no loss of optimality if we agree to the following restrictions: (a) object 1 can only be assigned to group 1; (b) object 2 can only be assigned to groups 1 or 2 and only to 1 if object 1 is also assigned to 1; (c) and in general, object j can be assigned to group $i < j$, only if object i is also assigned to group i . This implies in particular that:

$$X_{ii} = 1, \text{ if and only if object } i \text{ is the lowest indexed object in its group, and}$$

$$X_{ij} \text{ is defined only for } i \leq j.$$

Now we will look at several examples of grouping problems and show how to solve them.

11.7.2 Matching Problems, Groups of Size Two

The roommate assignment problem is a simple example of a grouping problem where the group size is two. An example of this is a problem solved at many universities at the start of the school year before the first-year or freshman students arrive. The rooms in a freshman dormitory typically take exactly two students. How should new incoming students be paired up? One approach that has been used is that for every possible pair of students, a score is calculated which is a measure of how well the school thinks this particular pair of students would fare as roommates. Considerations that enter into a score are things such as: a smoker should not be matched with a nonsmoker, a person who likes to study late at night should not be paired with a student who likes to get up early and study in the morning. Let us suppose we have computed the scores for all possible pairs of the six students: Joe, Bob, Chuck, Ed, Evan, and Sean. A scalar model for this problem might be:

```
! Maximize total score of pairs selected;
MAX= 9*X_JOE_BOB + 7*X_JOE_CHUCK + 4*X_JOE_ED
    + 6*X_JOE_EVAN + 3*X_JOE_SEAN + 2*X_BOB_CHUCK
    + 8*X_BOB_ED + X_BOB_EVAN + 7*X_BOB_SEAN
    + 3*X_CHUCK_ED + 4*X_CHUCK_EVAN + 9*X_CHUCK_SEAN
    + 5*X_ED_EVAN + 5*X_ED_SEAN + 6*X_EVAN_SEAN;

! Each student must be in exactly one pair;
[JOE] X_JOE_BOB + X_JOE_CHUCK + X_JOE_ED
    + X_JOE_EVAN + X_JOE_SEAN = 1;
[BOB] X_JOE_BOB + X_BOB_CHUCK + X_BOB_ED
    + X_BOB_EVAN + X_BOB_SEAN = 1;
[CHUCK] X_JOE_CHUCK + X_BOB_CHUCK + X_CHUCK_ED
    + X_CHUCK_EVAN + X_CHUCK_SEAN = 1;
[ED] X_JOE_ED + X_BOB_ED + X_CHUCK_ED + X_ED_EVAN
    + X_ED_SEAN = 1;
[EVAN] X_JOE_EVAN + X_BOB_EVAN + X_CHUCK_EVAN + X_ED_EVAN
    + X_EVAN_SEAN = 1;
[SEAN] X_JOE_SEAN + X_BOB_SEAN + X_CHUCK_SEAN
    + X_ED_SEAN + X_EVAN_SEAN = 1;
```

```

! Assignments must be binary, not fractional;
@BIN( X_JOE_BOB;    @BIN( X_JOE_CHUCK;    @BIN( X_JOE_ED;
@BIN( X_JOE_EVAN;  @BIN( X_JOE_SEAN;    @BIN( X_BOB_CHUCK;
@BIN( X_BOB_ED);   @BIN( X_BOB_EVAN;    @BIN( X_BOB_SEAN);
@BIN( X_CHUCK_ED); @BIN( X_CHUCK_EVAN); @BIN( X_CHUCK_SEAN);
@BIN( X_ED_EVAN);  @BIN( X_ED_SEAN);    @BIN( X_EVAN_SEAN);

```

Notice that there is a variable `X_JOE_BOB`, but not a variable `X_BOB_JOE`. This is because we do not care whose name is listed first on the door. We only care about which two are paired together. We say we are interested in unordered pairs.

A typical dormitory may have 60, or 600, rather than 6 students, so a general, set based formulation would be useful. The following formulation shows how to do this in LINGO. One thing we want to do in the model is to tell LINGO that we do not care about the order of persons in a pair. LINGO conveniently allows us to put conditions on which of all possible members (pairs in this case) of a set are to be used in a specific model. The key statement in the model is:

```

PXP( PERSON, PERSON) | &1 #LT# &2: VALUE, X;

```

The fragment, `PXP(PERSON, PERSON)`, by itself, tells LINGO that the set `PXP` should consist of all possible combinations, 6×6 for this example, of two persons. The conditional phrase, `| &1 #LT# &2`, however, tells LINGO to restrict the combinations to those in which the index number, `&1`, of the first person in a pair should be strictly less than the index number, `&2`, of the second person.

```

MODEL: ! (roomates.lng);
SETS:
  PERSON;
! Joe rooms with Bob means the same as
  Bob rooms with Joe, so we need only the
  upper triangle;
  PXP( PERSON, PERSON) | &1 #LT# &2: VALUE, X;
ENDSETS
DATA:
  PERSON = Joe  Bob  Chuck  Ed  Evan  Sean;

  Value =
        9    7    4    6    3    ! Joe;
         2    8    1    7    ! Bob;
          3    4    9    ! Chuck;
           5    5    ! Ed;
            6 ; ! Evan;

ENDDATA

! Maximize the value of the matchings;
MAX = @SUM( PXP(I,J): Value(i,j) * X(I,J));

! Each person appears in exactly one match;

```

```

@FOR( PERSON( K ):
    @SUM( PXP( K, J ): X( K, J ) ) + @SUM( PXP( I, K ): X( I, K ) ) = 1;
);
! No timesharing;
@FOR( PXP( I, J ): @BIN( X( I, J ) ) );
END

```

The constraint, $\text{@SUM}(\text{PXP}(K, J): X(K, J)) + \text{@SUM}(\text{PXP}(I, K): X(I, K)) = 1$ has two terms, the first where student K is the first person in the pair, the second summation is over the variables where student K is the second person in the pair. For example, in the scalar formulation, notice that ED is the first person in two of the pairs, and the second person of three of the pairs.

The following solution, with value 23, is found.

Variable	Value
X(JOE, EVAN)	1.000000
X(BOB, ED)	1.000000
X(CHUCK, SEAN)	1.000000

So Joe is to be paired with Evan, Bob with Ed, and Chuck with Sean. This model scales up well in that it can be easily solved for large numbers of objects, e.g., many hundreds.

For a different perspective on matching, see the later section on “stable matching”.

11.7.3 Groups with More Than Two Members

The following example illustrates a problem recently encountered by an electricity generating firm and its coal supplier. You are a coal supplier and you have a nonexclusive contract with a consumer owned and managed electric utility, Power to the People (PTTP). You supply PTTP by barge. Your contract with PTTP stipulates that the coal you deliver must have at least 13000 BTU’s per ton, no more than 0.63% sulfur, no more than 6.5% ash, and no more than 7% moisture. Historically, PTTP would not accept a barge if it did not meet the above requirements.

You currently have the following barge loads available.

Barge	BTU/ton	Sulfur%	Ash%	Moisture%
1	13029	0.57	5.56	6.2
2	14201	0.88	6.76	5.1
3	10630	0.11	4.36	4.6
4	13200	0.71	6.66	7.6
5	13029	0.57	5.56	6.2
6	14201	0.88	6.76	5.1
7	13200	0.71	6.66	7.6
8	10630	0.11	4.36	4.6
9	14201	0.88	6.76	5.1
10	13029	0.57	5.56	6.2
11	13200	0.71	6.66	7.6
12	14201	0.88	6.76	5.1

This does not look good. Only barges 1, 5, and 10 satisfy PTTT's requirement. What can we do? Suppose that after reading the fine print of your PTTT contract carefully, you initiate some discussions with PTTT about how to interpret the above requirements. There might be some benefits if you could get PTTT to reinterpret the wording of the contract so that the above requirements apply to collections of up to three barges. That is, if the average quality taken over a set of N barges, N less than four, meets the above quality requirements, then that set of N barges is acceptable. You may specify how the sets of barges are assembled. Each barge can be in at most one set. All the barges in a set must be in the same shipment.

Looking at the original data, we see, even though there are twelve barges, there are only four distinct barge types represented by the original first four barges. In reality, you would expect this: each barge type corresponding to a specific mine with associated coal type.

Modeling the barge grouping problem as an assignment problem is relatively straightforward. The essential decision variable is defined as $X(I, J)$ = number of barges of type I assigned to group J . Note we have retained the convention of not distinguishing between barges of the same type. Knowing there are twelve barges, we can restrict ourselves to at most six groups without looking further at the data. The reasoning is: Suppose there are seven nonempty groups. Then, at least two of the groups must be singletons. If two singletons are feasible, then so is the group obtained by combining them. Thus, we can write the following LINGO model:

```

MODEL:
SETS:
  MINE: BAVAIL;
  GROUP;
  QUALITY: QTARG;
! Composition of each type of MINE load;
  MXQ( MINE, QUALITY): QACT;
!assignment of which MINE to which group;
!no distinction between types;
  MXG( MINE, GROUP):X;
ENDSETS
DATA:
  MINE = 1..4;
      ! Barges available of each type(or mine);
  BAVAIL = 3 4 2 3;
  QUALITY = BTU, SULF, ASH, MOIST;
      ! Quality targets as upper limits;
  QTARG = - 13000 0.63 6.5 7;
      ! Actual qualities of each mine;
  QACT = -13029 0.57 5.56 6.2
          -14201 0.88 6.76 5.1
          -10630 0.11 4.36 4.6
          -13200 0.71 6.66 7.6;
! We need at most six groups;
  GROUP = 1..6;
  GRPSIZ = 3;
ENDDATA
! Maximize no. of barges assigned;
MAX = @SUM( MXG: X);
! Upper limit on group size;
@FOR( GROUP(J): @SUM( MINE( I): X( I, J))
      <= GRPSIZ;);
! Assign no more of a type than are available;
@FOR( MINE( I): @SUM( GROUP( J): X( I, J))
      <= BAVAIL( I));
! The blending constraints for each group;
@FOR( GROUP(J):
  @FOR( QUALITY ( H):
    @SUM( MINE( I): X( I, J) * QACT( I, H)) <=
    @SUM( MINE( I): X( I, J) * QTARG( H));
  );
! barges must be integers;
@FOR( MXG: @GIN( X));
END

```

The following solution shows that you can now sell ten barges, rather than three, to PTTT.

```
Objective value:                10.00000
Variable           Value
X( 1, 1)           1.000000
X( 2, 2)           2.000000
X( 3, 2)           1.000000
X( 1, 4)           2.000000
X( 4, 4)           1.000000
X( 2, 5)           2.000000
X( 3, 5)           1.000000
```

For example, group 1 is simply one barge of type 1. Group 2 consists two barges of type 2 and one barge of type 3. The above formulation may not scale well. The actual application typically had about 60 barges in a candidate set. The above formulation may be slow to solve problems of that size. The next section discusses how the partitioning approach can be efficiently used for such problems.

Solving with a Partitioning Formulation

Modest-sized integer programs can nevertheless be very difficult to solve. There are a number of rules that are useful when facing such problems. Two useful rules for difficult integer programs are:

- 1) Do Not Distinguish the Indistinguishable;
- 2) Presolve subproblems.

The barge matching example can be solved almost “by hand” with the matching or grouping (as opposed to the assignment) approach. Applying the rule “Presolve subproblems,” we can enumerate all feasible combinations of three or less barges selected from the four types. Applying the “Don’t distinguish” rule again, we do not have to consider combinations such as (1,1) and (2,2,2), because such sets are feasible if and only if the singleton sets (e.g., (1) and (2)) are also feasible. Thus, disregarding quality, there are four singleton sets, six doubleton sets, four distinct triplets (e.g., (1,2,3)) and twelve paired triplets (e.g., (1,1,2)) for a total of 26 combinations. It is not hard to show, even manually, that the only feasible combinations are (1), (1,1,4), and (2,2,3). Thus, the matching-like IP we want to solve to maximize the number of barges sold is:

```
Max = S001 + 3 * S114 + 3 * S223;
S001 + 2 * S114          <= 3 ;
!(No. of type 1 barges);
      2 * S223 <= 4 ;
!(No. of type 2 barges);
      S223 <= 2 ;
!(No. of type 3 barges);
      S114          <= 3 ;
!(No. of type 4 barges);
```

This is easily solved to give $S001 = 1$, $S114 = 1$, and $S223 = 2$, with an objective value of 10.

For the given data, we can ship at most ten barges. One such way of matching them, so each set satisfies the quality requirements is as follows:

Barges in set	Average Quality of the Set			
	BTU%	Sulfur%	Ash%	Moisture%
1	13029	0.57	5.56	6.2
4, 5, 10	13086	0.6167	5.927	6.667
2, 3, 6	13010	0.6233	5.96	4.933
8, 9, 12	13010	0.6233	5.96	4.933

This matches our LINGO derived solution.

11.7.4 Groups with a Variable Number of Members, Assignment Version

In many applications of the grouping idea, the group size may be variable. The following example from the financial industry illustrates. A financial services firm has financial objects (e.g., mortgages) it wants to “package” and sell. One of the features of a package is that it must contain a combination of objects whose values total at least one million dollars. For our purposes, we will assume this is the only qualification in synthesizing a package. We want to maximize the number of packages we form. We first give an assignment formulation. The key declaration in this formulation is:

```
OXO( OBJECT, OBJECT) | &1 #LE# &2: X;
```

This implies there will be a variable of the form $X(I, J)$ with always the index $I \leq J$. Our interpretation of this variable will be:

$X(I, J) = 1$ means object J is assigned to the same group as object I , and further,
 $X(I, I) = 1$ means object I is the lowest indexed object in that group.

```
MODEL:
! Object bundling model. (OBJBUNDL);
!A broker has a number of loans of size from $55,000 to $946,000.
The broker would like to group the loans into packages
so that each package has at least $1M in it,
and the number of packages is maximized;
! Keywords: bundling, financial, set packing;
SETS:  OBJECT: VALUE, OVER;
      OXO( OBJECT, OBJECT) | &1 #LE# &2: X;
ENDSETS
DATA:
OBJECT= A  B  C  D  E  F  G  H  I  J  K  L  M  N  P  Q  R;
VALUE=910 870 810 640 550 250 120 95 55 200 321 492 567 837 193 364 946;
! The value in each bundle must be >= PKSIZE;
PKSIZE = 1000;
ENDDATA
!-----;
! Definition of variables;
! X( I, I) = 1 if object I is lowest numbered
      object in its package;
! X( I, J) = 1 if object j is assigned to package I;
! Maximize number of packages assembled;
MAX = @SUM( OBJECT( I): X( I, I));
```

```

@FOR( OBJECT( K):
! Each object can be assigned to at most one package;
  @SUM( OXO( I, K): X( I, K)) <= 1;
! A package must be at least PSIZE in size;
  @SUM( OXO( K, J): VALUE( J) * X( K, J))
    - OVER( K) = PKSIZE * X( K, K);
);
! The X( I, J) must = 0 or 1;
@FOR( OXO( I, J): @BIN( X( I, J)));
END

```

A solution is:

Variable	Value
X(A, A)	1.000000
X(A, H)	1.000000
X(B, B)	1.000000
X(B, F)	1.000000
X(C, C)	1.000000
X(C, J)	1.000000
X(D, D)	1.000000
X(D, Q)	1.000000
X(E, E)	1.000000
X(E, L)	1.000000
X(G, G)	1.000000
X(G, K)	1.000000
X(G, M)	1.000000
X(I, I)	1.000000
X(I, R)	1.000000
X(N, N)	1.000000
X(N, P)	1.000000

Thus, eight packages are constructed. Namely: *AH*, *BF*, *CJ*, *DQ*, *EL*, *IR*, *JN*, *GKM*, and *NP*. It happens that every object appears in some package. There are alternate packings of all the objects into eight groups. Thus, one may wish to consider secondary criteria for choosing one alternate optimum over another (e.g., the largest package should be as close as possible to one million in size). The worst package in the fairness sense in the above solution is *BF*. It is over the target of 1,000,000 by 120,000.

11.7.5 Groups with A Variable Number of Members, Packing Version

An alternative approach is first to enumerate either all possible or all interesting feasible groups and then solve an optimization problem of the form:

Maximize value of the groups selected
subject to:
Each object is in at most one of the selected groups.

The advantage of this formulation is, when it can be used, it typically can be solved more easily than the assignment formulation. The disadvantages are it may have a huge number of decision variables, especially if the typical group size is more than three. If there are n distinct objects, and all groups are of size k , then there are $n!/(k! (n-k)!)$ distinct groups. For example, if $n = 50$ and $k = 3$, then there are 19,600 candidate groups.

This formulation uses the idea of composite variables. This is frequently a useful approach for a problem for which the original or “natural” formulation is difficult to solve. Setting a particular composite variable to 1 represents setting a particular combination of the original variables to 1. We generate only those composite variables that correspond to feasible combinations of the original variables. This effectively eliminates many of the fractional solutions that would appear if one solved the LP relaxation of the original formulation. The composite variable idea is a form of what is sometimes called column generation. The path formulation in network models is also an example of the use of composite variables.

Example: Packing Financial Instruments, revisited.

The packing approach to formulating a model for this problem constructs all possible packages or groups that just satisfy the one million minimum. The general form of the LP/IP is:

Maximize value of packages selected
subject to:
Each object appears in at most one selected package.

In the formulation below, we will use sparse sets to represent our packages. We assume that we need not consider packages of more than four objects. An attractive feature of the packing/partitioning formulation is that we can easily attach an essentially arbitrary score to each possible group. In particular, the following formulation applies a squared penalty to the extent to which a package of loans exceeds the target of \$1M.

```
MODEL:
! Object bundling model. (OBJBUNDH);
! A broker has a number of loans of size from $55,000 to
$946,000.
The broker would like to group the loans into packages
so that each package has at least $1M in it, preferably
not much more,
and the number of packages is maximized;
! Keywords: bundling, financial, set packing;
SETS:
OBJECT: VALUE;
ENDSETS
DATA:
OBJECT = A B C D E F G H I J K L M N P Q R;
VALUE = 910 870 810 640 550 250 120 95 55 200 321 492 567 837 193 364
946;
! The value in each bundle must be >= PKSIZE;
PKSIZE = 1000;
ENDDATA
SETS:
!Enumerate all 2,3, and 4 object unordered sets ≤ package
size;
BNDL2 ( OBJECT, OBJECT) | &1 #LT# &2
#AND# (VALUE (&1) + VALUE (&2)) #GE# PKSIZE: X2, OVER2;
BNDL3 ( OBJECT, OBJECT, OBJECT) | &1 #LT# &2 #AND# &2 #LT#
&3
```

```

#AND# ( VALUE(&1) + VALUE(&2) + VALUE(&3) #GE# PKSIZE):
  X3, OVER3;
BNDL4( OBJECT, OBJECT, OBJECT, OBJECT) | &1 #LT# &2
#AND# &2 #LT# &3 #AND# &3 #LT# &4 #AND# (( VALUE(&1) +
VALUE(&2) + VALUE(&3) + VALUE(&4)) #GE# PKSIZE): X4,
OVER4;
ENDSETS
!-----;
!Compute the overage of each bundle;
@FOR( BNDL2( I,J):
  OVER2( I,J) = VALUE( I) + VALUE( J) - PKSIZE;
);
@FOR( BNDL3( I,J,K):
  OVER3( I,J,K) = VALUE( I)+VALUE( J)+VALUE( K) - PKSIZE
);
@FOR( BNDL4( I,J,K,L):
  OVER4( I,J,K,L) = VALUE( I)+VALUE( J)+VALUE( K)+VALUE( L)-
PKSIZE;
);

! Maximize score of packages assembled. Penalize a package
that
is over the minimum package size;
MAX= @SUM( BNDL2( I,J): X2( I,J) * (1-(OVER2( I,J)/PKSIZE)^2))
+@SUM( BNDL3( I,J,K):
      X3( I, J,K) * (1-(OVER3( I,J,K)/PKSIZE)^2))
+ @SUM( BNDL4( I,J,K,L):
      X4( I,J,K,L) * (1-
(OVER4( I,J,K,L)/PKSIZE)^2));

@FOR( OBJECT( M):
! Each object M can be in at most one of the selected bundles;
@SUM( BNDL2( I, J)| I #EQ# M #OR# J #EQ# M: X2( I, J))
+ @SUM( BNDL3( I, J, K)| I #EQ# M #OR# J #EQ# M #OR# K #EQ#
M:
      X3( I, J, K))
+ @SUM( BNDL4( I, J, K, L)|
      I #EQ# M #OR# J #EQ# M #OR# K #EQ# M #OR# L #EQ# M:
      X4( I, J, K, L)) <= 1;
);

! The X's must = 0 or 1;
@FOR( BNDL2( I, J): @BIN( X2( I, J)););
@FOR( BNDL3( I, J, K): @BIN( X3( I, J, K)););
@FOR( BNDL4( I, J, K, L): @BIN( X4( I, J, K, L)););
END

```

```

Global optimal solution found at iteration:          19
Objective value:                                  7.989192
      Variable          Value
      X2 ( A, H)         1.000000
      OVER2 ( A, H)       5.000000
      X2 ( B, P)         1.000000
      OVER2 ( B, P)       63.000000
      X2 ( C, F)         1.000000
      OVER2 ( C, F)       60.000000
      X2 ( D, Q)         1.000000
      OVER2 ( D, Q)       4.000000
      X2 ( E, L)         1.000000
      OVER2 ( E, L)       42.000000
      X2 ( I, R)         1.000000
      OVER2 ( I, R)       1.000000
      X2 ( J, N)         1.000000
      OVER2 ( J, N)       37.000000
      X3 ( G, K, M)       1.000000
      OVER3 ( G, K, M)    8.000000

```

Notice that this allocation is slightly more balanced than the previous solution based on the assignment formulation. The largest “overage” is 63,000 rather than 120,000. This is because the grouping formulation provided an easy way to penalize large packages.

11.7.6 Groups with A Variable Number of Members, Cutting Stock Problem

Another application in which the partitioning or packing approach has worked well is the cutting stock problem in the paper and steel industry. We revisit the example introduced in chapter 7. There we manually enumerated all possible patterns or packings drawn from 8 different finished good widths into each of three different raw material widths. The formulation below automatically enumerates all possible patterns. For each raw material width, the formulation automatically enumerates all possible groupings of 1, 2, ..., 7 finished good widths so that the sum of the finished good widths is less than or equal to the raw material width.

One notable feature of this formulation is that it introduces a shortcut that may be important in keeping computation time low when there are many, e.g., more than 20, objects. To illustrate the shortcut, consider the three declarations:

```

! Enumerate all possible cutting patterns with 1 fg;
  rxf (rm, fg) | lenf (&2) #le# lenr (&1): x1;
! Enumerate all possible patterns with 2 fg;
  rxf2 ( rxf, fg) |
    &2 #le# &3 #and# (lenf (&2) + lenf (&3) #le# lenr (&1)): x2;
! Enumerate all possible patterns with 3 fg;
  rxf3 ( rxf2, fg) | &3 #le# &4
    #and# (lenf (&2) + lenf (&3) + lenf (&4) #le# lenr (&1)): x3;

```

The declaration `rx f (rm, fg)`, by itself, tells LINGO to generate all combinations of one raw material and one finished good. The condition `| lenf(&2) #le# lenr(&1)`, however, tells LINGO to not generate a combination of a raw material (the index `&1`) and finished good (index `&2`) for which the length (or width depending upon your orientation) of the finished good is greater than that of the raw material. So, for example, the combination `(R36, F38)` will not be a member of `rx f`. There will be four elements in `rx f` for which the first item of the pair is R36, namely `(R36, F34)`, `(R36, F24)`, `(R36, F15)`, and `(R36, F10)`.

Now consider how to generate all feasible combinations containing two finished good widths. The obvious declaration would be: `rx f2 (rm, fg, fg) | &2 #le# &3 #and# (lenf(&2) + lenf(&3) #le# lenr(&1))`

The condition `&2 #le# &3` says we do not care about the order of the finished goods in the pattern, so we might as well restrict ourselves to listing the finished goods in the pattern in sorted order. The condition `lenf(&2) + lenf(&3) #le# lenr(&1)` restricts the elements of set `rx f2` to feasible ones. This declaration would be valid, but we did not do it. Why? Instead we used the declaration `rx f2 (rx f, fg)`. The latter was used mainly for computational reasons. With the latter, LINGO considers every combination of the elements of the set `rx f` and each finished good. Consider the case when the raw material is `r36`. If the declaration `rx f2 (rm, fg, fg)` is used, then LINGO would look at $8 * 8 = 64$ combinations of two finished goods and keep only the four combinations `(r36, f24, f10)`, `(r36, f15, f15)`, `(r36, f15, f10)`, and `(r36, f10, f10)`. If on the other hand, the declaration `rx f2 (rx f, fg)` is used, then when the raw material is R36, LINGO will only consider $4 * 8 = 32$ combinations. The 4 arises because set `rx f` contains only 4 elements for which the first member of the pair is R36. For sets `rx f3`, and higher, the computational savings can be even higher.

```
! Cutting stock solver(cutgent);
! Keywords: cutting stock;
sets:
! Each raw material has a size(length) and quantity;
  rm: lenr, qr;
! Ditto for each finished good;
  fg: lenf, qf;
endsets
data:
! Describe the raw materials available;
  rm, lenr, qr =
  R72  72  9999
  R45  48  9999
  R36  36  9999;
! Describe the finished goods needed;
  fg, lenf, qf =
  F60  60  500
  F56  56  400
  F42  42  300
  F38  38  450
  F34  34  350
  F24  24  100
```

```

F15 15 800
F10 10 1000;
enddata

sets:
! Enumerate all possible cutting patterns with 1 fg;
  rxf(rm,fg) | lenf(&2) #le# lenr(&1): x1;
! Enumerate all possible patterns with 2 fg;
  rxf2( rxf, fg) |
    &2 #le# &3 #and# (lenf(&2) + lenf(&3) #le# lenr(&1)):
x2;
! Enumerate all possible patterns with 3 fg;
  rxf3( rxf2, fg) | &3 #le# &4 #and#
    (lenf(&2) + lenf(&3)+ lenf(&4) #le# lenr(&1)):
x3;
! Enumerate all possible patterns with 4 fg;
  rxf4( rxf3, fg) | &4 #le# &5 #and#
    (lenf(&2) + lenf(&3) + lenf(&4)+lenf(&5) #le# lenr(&1)):
x4;
! Enumerate all possible patterns with 5 fg;
  rxf5( rxf4, fg) | &5 #le# &6 #and# (lenf(&2) + lenf(&3)+
lenf(&4)+lenf(&5)+lenf(&6)
    #le# lenr(&1)): x5;
! Enumerate all possible patterns with 6 fg;
  rxf6( rxf5, fg) | &6 #le# &7 #and# (lenf(&2) + lenf(&3)+
lenf(&4)+lenf(&5)
    +lenf(&6)+lenf(&7) #le# lenr(&1)): x6;

endsets

! Minimize length of material used;

min = @sum( rxf(r, f1): lenr(r)*x1(r, f1))
      + @sum( rxf2(r, f1, f2): lenr(r)*x2(r, f1, f2))
      + @sum( rxf3(r, f1, f2, f3): lenr(r)*x3(r, f1, f2, f3))
      + @sum( rxf4(r, f1, f2, f3, f4): lenr(r)*x4(r, f1, f2, f3, f4))
      + @sum( rxf5(r, f1, f2, f3, f4, f5):
lenr(r)*x5(r, f1, f2, f3, f4, f5))
      + @sum( rxf6(r, f1, f2, f3, f4, f5, f6):
lenr(r)*x6(r, f1, f2, f3, f4, f5, f6));

! We have to satisfy each finished good demand;
@for( fg(f):
  @sum(rxf(r, f): x1(r, f))
  + @sum(rxf2(r, f1, f2) | f #eq# f1: x2(r, f1, f2))
  + @sum(rxf2(r, f1, f2) | f #eq# f2: x2(r, f1, f2))
  + @sum(rxf3(r, f1, f2, f3) | f #eq# f1: x3(r, f1, f2, f3))
  + @sum(rxf3(r, f1, f2, f3) | f #eq# f2: x3(r, f1, f2, f3))
  + @sum(rxf3(r, f1, f2, f3) | f #eq# f3: x3(r, f1, f2, f3))

```

```

+ @sum(rxf4(r, f1, f2, f3, f4) | f #eq# f1: x4(r, f1, f2, f3, f4))
+ @sum(rxf4(r, f1, f2, f3, f4) | f #eq# f2: x4(r, f1, f2, f3, f4))
+ @sum(rxf4(r, f1, f2, f3, f4) | f #eq# f3: x4(r, f1, f2, f3, f4))
+ @sum(rxf4(r, f1, f2, f3, f4) | f #eq# f4: x4(r, f1, f2, f3, f4))
+ @sum(rxf5(r, f1, f2, f3, f4, f5) | f #eq# f1:
x5(r, f1, f2, f3, f4, f5))
+ @sum(rxf5(r, f1, f2, f3, f4, f5) | f #eq# f2:
x5(r, f1, f2, f3, f4, f5))
+ @sum(rxf5(r, f1, f2, f3, f4, f5) | f #eq# f3:
x5(r, f1, f2, f3, f4, f5))
+ @sum(rxf5(r, f1, f2, f3, f4, f5) | f #eq# f4:
x5(r, f1, f2, f3, f4, f5))
+ @sum(rxf5(r, f1, f2, f3, f4, f5) | f #eq# f5:
x5(r, f1, f2, f3, f4, f5))
+ @sum(rxf6(r, f1, f2, f3, f4, f5, f6) | f #eq# f1:
x6(r, f1, f2, f3, f4, f5, f6))
+ @sum(rxf6(r, f1, f2, f3, f4, f5, f6) | f #eq# f2:
x6(r, f1, f2, f3, f4, f5, f6))
+ @sum(rxf6(r, f1, f2, f3, f4, f5, f6) | f #eq# f3:
x6(r, f1, f2, f3, f4, f5, f6))
+ @sum(rxf6(r, f1, f2, f3, f4, f5, f6) | f #eq# f4:
x6(r, f1, f2, f3, f4, f5, f6))
+ @sum(rxf6(r, f1, f2, f3, f4, f5, f6) | f #eq# f5:
x6(r, f1, f2, f3, f4, f5, f6))
+ @sum(rxf6(r, f1, f2, f3, f4, f5, f6) | f #eq# f6:
x6(r, f1, f2, f3, f4, f5, f6))

>= qf(f);
);

```

! We cannot use more raw material than is available;

```

@for( rm( r ):
@sum(rxf(r, f): x1(r, f))
+ @sum(rxf2(r, f1, f2): x2(r, f1, f2))
+ @sum(rxf3(r, f1, f2, f3): x3(r, f1, f2, f3))
+ @sum(rxf4(r, f1, f2, f3, f4): x4(r, f1, f2, f3, f4))
+ @sum(rxf5(r, f1, f2, f3, f4, f5): x5(r, f1, f2, f3, f4, f5))
+ @sum(rxf6(r, f1, f2, f3, f4, f5, f6): x6(r, f1, f2, f3, f4, f5, f6))
<= qr(r);
);

```

! Can only run integer quantities of each pattern;

```

@for(rxf: @gin(x1));
@for(rxf2: @gin(x2));
@for(rxf3: @gin(x3));
@for(rxf4: @gin(x4));
@for(rxf5: @gin(x5));
@for(rxf6: @gin(x6));

```

If you click on LINGO | Generate menu item, to display the scalar version of the model, you can see that the constraint for the 56 inch width is(hopefully reassuringly):

$$X2_R72_F56_F15 + X2_R72_F56_F10 + X1_R72_F56 \geq 400 ;$$

When we click on the Solve icon we get the solution:

Global optimal solution found at iteration: 31
Objective value: 119832.0

	Variable	Value
	X2 (R72, F60, F10)	500.0000
	X2 (R72, F56, F15)	400.0000
	X2 (R72, F38, F34)	350.0000
	X3 (R72, F42, F15, F15)	186.0000
	X3 (R72, F38, F24, F10)	100.0000
	X4 (R72, F42, F10, F10, F10)	114.0000
	X4 (R45, F15, F10, F10, F10)	2.000000
	X6 (R72, F15, F15, F10, F10, F10, F10)	13.000000

11.7.7 Groups with A Variable Number of Members, Vehicle Routing

The following vehicle routing example demonstrates that you can in fact perform a little optimization computation as part of the column or group generation. The example we use is a variation of the vehicle routing problem considered in section 11.6.3. The first and major part of this model is devoted to enumerating all minimal feasible trips with at most seven stops. By feasible trip, we mean that the amount of material to be delivered to the stops in the trip does not exceed the vehicle capacity of 18 pallets. By minimal we mean that for a trip that visits a given set of stops, the trip visits the stops in a sequence that minimizes the distance traveled.

Given that all minimal feasible trips have been generated, the following simple integer program is solved:

Minimize Cost of trips selected;
Subject to:
For each stop:
Exactly one trip includes this stop.

This little example has 15 stops, so the integer program has 15 constraints, and a large number of 0/1 variables(about 7300 in fact), equal in number to the number of minimal feasible trips.

The tricky part is how we generate the sets of minimal feasible trips, PSET2, PSET3, etc. and the associated minimal distances, D2(), D3(), etc. To start understanding ideas, consider the variable D4 (I, J, K, L). It has the following definition.

D4 (I, J, K, L) = minimum distance required to start at the depot, visit stops I, J, and K in any order and then visit stop L. If DIST (I, J) is the distance matrix, then Held and Karp(1962) observed that if D3 is defined in similar fashion, then D4 can be computed by the dynamic programming recursion:

$$D4 (I, J, K, L) = \min [D3 (I, J, K) + DIST (K, L) , \\ D3 (I, K, J) + DIST (J, L) , \\ D3 (J, K, I) + DIST (I, L)]$$

The complete formulation follows.

```

MODEL:    ! (vrngenxt);
! The Vehicle Routing Problem (VRP) occurs in many service
systems such as delivery, customer pick-up, repair and
maintenance. A fleet of vehicles, each with fixed
capacity, starts at a common depot and returns to the
depot after visiting locations where service is demanded.
This LINGO model generates all feasible one vehicle routes
and then chooses the least cost feasible multi-vehicle
combination;
SETS:
CITY: Q;
! Q(I) = amount required at city I(given),
      must be delivered by just 1 vehicle;
CXC(CITY, CITY): DIST;
! DIST(I,J) = distance from city I to city J
ENDSETS
DATA:
CITY= Chi Den Frsn Hous  KC  LA Oakl Anah Peor Phnx Prtl Rvrs Sacr SLC Sntn SBrn;
! Amount to be delivered to each customer;
Q= 0   6   3   7   7  18   4   5   2   6   7   2   4   3   3   2  ;
! city 1 represents the common depot, i.e. Q(1) = 0;
! Distance from city I to city J is same (but need not be) from J to I;
DIST= ! To City;
!Chi  Den Frsn Hous  KC  LA Oakl Anah Peor Phnx Prtl Rvrs Sacr  SLC Sntn SBrn From;
0   996 2162 1067  499 2054 2134 2050  151 1713 2083 2005 2049 1390 1187 1996 ! Chicago;
996   0 1167 1019  596 1059 1227 1055  904  792 1238 1010 1142  504 939 1001 ! Denver;
2162 1167   0 1747 1723  214  168  250 2070  598  745  268  162  814 1572 265 ! Fresno;
1067 1019 1747   0  710 1538 1904 1528  948 1149 2205 1484 1909 1438  197 1533 ! Huston;
499  596 1723  710   0 1589 1827 1579  354 1214 1809 1535 1742 1086  759 1482 ! K-City;
2054 1059 214 1538 1589   0 371  36 1943  389  959  54 376  715 1363  59 ! L. A.;
2134 1227 168 1904 1827 371  0 407 2043  755  628  425  85  744 1729 422 ! Oaklnd;
2050 1055 250 1528 1579  36 407  0 1933  379  995  45 412  711 1353  55 ! Anahm;
151  904 2070  948  354 1943 2043 1933  0 1568 2022 1889 1958 1299 1066 1887 ! Peoria;
1713  792  598 1149 1214  389  755  379 1568  0 1266  335  760  648  974  333 ! Phnix;
2083 1238  745 2205 1809  959  628  995 2022 1266  0 1001  583  767 2086  992 ! Prtlnd;
2005 1010 268 1484 1535  54 425  45 1889  335 1001  0 430  666 1309  10 ! Rvrsde;
2049 1142 162 1909 1742 376  85 412 1958  760  583  430  0 659 1734 427 ! Scrmto;
1390  504  814 1438 1086  715  744  711 1299  648  767  666  659  0 1319  657 ! SLC;
1187  939 1572  197  759 1363 1729 1353 1066  974 2086 1309 1734 1319  0 1307 ! SAnt;
1996 1001 265 1482 1533  59 422  55 1887  333  992  10 427  657 1307  0 ! SBrn;;
! VCAP is the capacity of a vehicle in 40"x48" pallets;
VCAP = 18;
ENDDATA
SETS:
! Enumerate all sets of various sizes of cities that are load
feasible;
SET2(CITY,CITY) |&1 #GT# 1 #AND# &1 #LT# &2
#AND# (Q(&1)+Q(&2)#LE# VCAP) ;;
SET3(SET2,CITY) |&2 #LT# &3
#AND# (Q(&1)+Q(&2)+Q(&3)#LE# VCAP) ;;
SET4(SET3,CITY) |&3 #LT# &4
#AND# (Q(&1)+Q(&2)+Q(&3)+Q(&4)#LE# VCAP) ;;
SET5(SET4,CITY) |&4 #LT# &5

```

```

        #AND# (Q (&1)+Q (&2)+Q (&3)+Q (&4)+Q (&5) #LE# VCAP) ;;
SET6 (SET5,CITY) | &5 #LT# &6
        #AND# (Q (&1)+Q (&2)+Q (&3)+Q (&4)+Q (&5)+Q (&6) #LE#
VCAP) ;;
SET7 (SET6,CITY) | &6 #LT# &7
        #AND# (Q (&1)+Q (&2)+Q (&3)+Q (&4)+Q (&5)+Q (&6)+Q (&7) #LE#
VCAP) ;;

! Enumerate all partially ordered sets with a
  specific city as the last one;
PSET2 (CITY,CITY) | &1 #GT# 1 #AND# &1#NE#&2
        #AND# (Q (&1)+Q (&2) #LE# VCAP) : D2,X2;
PSET3 (SET2,CITY) | &1#NE#&3 #AND# &2#NE#&3
        #AND# (Q (&1)+Q (&2)+Q (&3) #LE# VCAP) :
D3,X3;
PSET4 (SET3,CITY) | &1#NE#&4 #AND# &2#NE#&4 #AND# &3 #NE# &4
        #AND# (Q (&1)+Q (&2)+Q (&3)+Q (&4) #LE# VCAP) :
D4,X4;
PSET5 (SET4,CITY) | &1#NE#&5 #AND# &2#NE#&5 #AND# &3 #NE# &5
        #AND# &4 #NE# &5
        #AND# (Q (&1)+Q (&2)+Q (&3)+Q (&4)+Q (&5) #LE# VCAP) :
D5,X5;
PSET6 (SET5,CITY) | &1#NE#&6 #AND#
        &2#NE#&6 #AND# &3 #NE# &6 #AND# &4 #NE# &6 #AND# &5
#NE# &6
        #AND# (Q (&1)+Q (&2)+Q (&3)+Q (&4)+Q (&5)+Q (&6) #LE# VCAP) :
D6,X6;
PSET7 (SET6,CITY) | &1#NE#&7 #AND# &2#NE#&7 #AND# &3#NE#&7
#AND#
        &4#NE#&7 #AND# &5#NE#&7 #AND# &6#NE#&7
        #AND# (Q (&1)+Q (&2)+Q (&3)+Q (&4)+Q (&5)+Q (&6)+Q (&7) #LE# VCAP) :
D7,X7;
ENDSETS

! Compute shortest distance to visit all cities in PSET, and
  ending up at last city in each
  partially ordered set, using Held&Karp DP.
Essential idea:
DS( S,t) = minimum distance to visit all cities in
  S and then end up at t. The recursion is:
DS( S, t) = min{k in S: DS(S-k,k) + DIST(k,t)};
@FOR (PSET2 (I,J) :
D2 (I,J) = DIST (1,I) + DIST (I,J);
@BIN (X2);
);
@FOR (PSET3 (I,J,K) :
! @SMIN is the min of a list of scalars. D3(I,J,K) = min cost
of

```

```

    starting at 1, visiting I and J in some order, and then K;
    D3(I,J,K) = @SMIN( D2(I,J) + DIST(J,K), D2(J,I) +
DIST(I,K) );
    @BIN(X3);
    );
@FOR(PSET4(I,J,K,L) :
!D4(I,J,K,L) = min cost of starting at 1, visiting I, J, & K
in some order, and then L;
D4(I,J,K,L) =
    @SMIN( D3(I,J,K)+DIST(K,L),
           D3(I,K,J)+DIST(J,L),
           D3(J,K,I)+DIST(I,L) );
    @BIN(X4);
    );

@FOR(PSET5(I,J,K,L,M) :
D5(I,J,K,L,M) =
    @SMIN( D4(I,J,K,L)+DIST(L,M),
           D4(I,J,L,K)+DIST(K,M),
           D4(I,K,L,J)+DIST(J,M),
           D4(J,K,L,I)+DIST(I,M) );
    @BIN(X5);
    );

@FOR(PSET6(I,J,K,L,M,N) :
D6(I,J,K,L,M,N) =
    @SMIN( D5(I,J,K,L,M)+DIST(M,N),
           D5(I,J,K,M,L)+DIST(L,N),
           D5(I,J,L,M,K)+DIST(K,N),
           D5(I,K,L,M,J)+DIST(J,N),
           D5(J,K,L,M,I)+DIST(I,N) );
    @BIN(X6);
    );

@FOR(PSET7(I,J,K,L,M,N,P) :
D7(I,J,K,L,M,N,P) =
    @SMIN( D6(I,J,K,L,M,N)+DIST(N,P),
           D6(I,J,K,L,N,M)+DIST(M,P),
           D6(I,J,K,M,N,L)+DIST(L,P),
           D6(I,J,L,M,N,K)+DIST(K,P),
           D6(I,K,L,M,N,J)+DIST(J,P),
           D6(J,K,L,M,N,I)+DIST(I,P) );
    @BIN(X7);
    );

! and finally, the optimization model...
Min cost of routes chosen, over complete routes ending back
at 1;

```

```

Min =
+ @SUM( PSET2 (I,J) | J #EQ# 1: D2 (I,J) *X2 (I,J) )
+ @SUM( PSET3 (I,J,K) | K #EQ# 1: D3 (I,J,K) *X3 (I,J,K) )
+ @SUM( PSET4 (I,J,K,L) | L #EQ# 1: D4 (I,J,K,L) *X4 (I,J,K,L) )
+ @SUM( PSET5 (I,J,K,L,M) | M #EQ# 1:
D5 (I,J,K,L,M) *X5 (I,J,K,L,M) )
+ @SUM( PSET6 (I,J,K,L,M,N) | N #EQ# 1:
D6 (I,J,K,L,M,N) *X6 (I,J,K,L,M,N) )
+ @SUM( PSET7 (I,J,K,L,M,N,P) | P #EQ# 1:
D7 (I,J,K,L,M,N,P) *X7 (I,J,K,L,M,N,P) );

! Each city must be on exactly one complete route;
@FOR( CITY(I1) | I1 #GT# 1:
+ @SUM( PSET2 (I,J) | J #EQ# 1 #AND# ( I #EQ# I1): X2 (I,J) )
+ @SUM( PSET3 (I,J,K) |K #EQ# 1 #AND# (I#EQ#I1 #OR# J#EQ#
I1):
X3 (I,J,K) )
+ @SUM( PSET4 (I,J,K,L) |L #EQ# 1 #AND#
(I#EQ#I1 #OR# J#EQ# I1 #OR# K#EQ# I1): X4 (I,J,K,L) )
+ @SUM( PSET5 (I,J,K,L,M) |M #EQ# 1 #AND#
(I#EQ#I1 #OR# J#EQ# I1 #OR# K#EQ# I1 #OR# L#EQ#I1):
X5 (I,J,K,L,M) )
+ @SUM( PSET6 (I,J,K,L,M,N) |N #EQ# 1 #AND#
(I#EQ#I1 #OR# J#EQ# I1 #OR# K#EQ# I1 #OR# L#EQ#I1
#OR# M#EQ#I1): X6 (I,J,K,L,M,N) )
+ @SUM( PSET7 (I,J,K,L,M,N,P) |P #EQ# 1 #AND#
(I#EQ#I1 #OR# J#EQ#I1 #OR# K#EQ#I1 #OR# L#EQ#I1
#OR# M#EQ#I1 #OR# N#EQ#I1)
: X7 (I,J,K,L,M,N,P) = 1;
);

```

It takes about 4 seconds to get the following solution

Global optimal solution found at iteration:	134	
Objective value:	17586.00	
	Variable	Value
	X2 (LA, CHI)	1.000000
	X3 (KC, PEOR, CHI)	1.000000
	X4 (DEN, HOUS, SNTN, CHI)	1.000000
	X5 (FRSN, OAKL, PRTL, SACR, CHI)	1.000000
	X6 (ANAH, PHNX, RVRS, SLC, SBRN, CHI)	1.000000

The obvious question is, how well does this formulation scale up? The final set partitioning integer program is not too challenging. The big challenge is generating and storing the possibly huge number

of trips. A crucial consideration is the number of stops per trip. If this is small, e.g., three, then the number of trips will be manageable. A typical vehicle routing problem may have around 100 stops. The number of possible minimal distance trips, each of which visit three out of 100 stops, is $100!/[3!97!] = 161,700$. This is a manageable number of variables for an efficient IP solver.

11.8 Linearizing Products of Variables

We have previously seen products of 0/1 variables, such as $y_1 \times y_2$ and y_1^2 can be represented by linear expressions by means of a simple transformation. This transformation generalizes to the case of the product of a 0/1 variable and a continuous variable.

To illustrate, suppose the product $x \times y$ appears in a model, where y is 0/1 while x is nonnegative continuous. We want to replace this nonlinear component by a (somewhat bigger) linear component. If we have an upper bound (M_x) on the value of x , an upper bound (M_y) on the product $x \times y$, and we define $P = x \times y$, then the following linear constraints will cause P to take on the correct value:

$$\begin{aligned} P &\leq x \\ P &\leq M_y \times y \\ P &\geq x - M_x \times (1 - y) \end{aligned}$$

Hanson and Martin (1990) show how this approach is useful in setting prices for products when we allow bundling of products. Bundle pricing is a form of quantity discounting. Examples of products that might be bundled are (a) airfare, hotel, rental car, tours, and meals or (b) computer, monitor, printer, and hard disk. Stigler (1963) showed how a movie distributor might improve profits by leasing bundles of movies rather than leasing individual movies. Bundling assumes it is easy for the seller to assemble the bundle and difficult for a buyer to unbundle. Otherwise, a reseller could buy the bundle at a discount and then sell the individual components at a markup.

11.8.1 Example: Bundling of Products

Microland Software has recently acquired an excellent word processing product to complement its own recently developed spreadsheet product. Microland is contemplating offering the combination of the two products for a discount. After demonstrating the products at a number of diverse professional meetings, Microland developed the following characterization of the market:

Market Segment	Size in 10,000	Maximum Price Market Segment is Willing To Pay for Various Bundles		
		Spreadsheet Only	Wordprocessor Only	Both
Business/Scientific	7	450	110	530
Legal/Administrative	5	75	430	480
Educational	6	290	250	410
Home	4.5	220	380	390

We will refer to each market segment as simply a “customer”. Economic theory suggests a customer will buy the product that gives the greatest consumer surplus, where consumer surplus is defined as the price the customer is willing to pay for the product (the “reservation price”) minus the market price for the product. For example, if the prices for the three bundles, spreadsheet only, word

processor only, and both together, were set respectively at 400, 150, and 500, then the business/scientific market would buy the spreadsheet alone because the consumer surplus is 50 vs. -40 and 30 for the other two bundles.

To give a general model of this situation, define:

- R_{ij} = reservation price of customer i for bundle j ,
- N_i = “size of customer” i (i.e., number of individual customers in segment i),
- s_i = consumer surplus achieved by customer i ,
- y_{ij} = 1 if customer i buys bundle j , 0 otherwise,
- x_j = price of bundle j set by the seller.

We will treat the empty bundle as just another bundle, so we can say every customer buys exactly one bundle.

The seller, Microland, would like to choose the x_j to:

$$\text{Maximize } \sum_i \sum_j N_i y_{ij} x_j$$

The fact that each customer will buy exactly one bundle is enforced with:

For each customer i :

$$\sum_j y_{ij} = 1$$

For each customer i , its achieved consumer surplus is:

$$s_i = \sum_j (R_{ij} - x_j) y_{ij}$$

Customer i will buy only the bundle j for which its consumer surplus, s_i , is the maximum. This is enforced by the constraints:

For each customer i and bundle j :

$$s_i \geq R_{ij} - x_j$$

A difficulty with the objective function and the consumer surplus constraints is they involve the product $y_{ij}x_j$. Let us follow our previous little example and replace the product $y_{ij}x_j$ by P_{ij} . If M_j is an upper bound on x_j , then, proceeding as before, to enforce the definition $P_{ij} = y_{ij}x_j$, we need the constraints:

$$\begin{aligned} P_{ij} &\leq x_j \\ P_{ij} &\leq R_{ij} y_{ij} \\ P_{ij} &\geq x_j - (1 - y_{ij})M_j. \end{aligned}$$

Making these adjustments to the model, we get:

$$\text{Maximize } \sum_i \sum_j N_i P_{ij}$$

subject to:

For each customer i

$$\sum_j y_{ij} = 1;$$

For each customer i , bundle j :

$$s_i \geq R_{ij} - x_j;$$

For each customer i :

$$s_i = \sum_j (R_{ij} y_{ij} - P_{ij});$$

To enforce the nonlinear condition $P_{ij} = y_{ij} x_j$, we have for each i and j :

$$P_{ij} \leq x_j$$

$$P_{ij} \leq R_{ij} y_{ij}$$

$$P_{ij} \geq x_j - (1 - y_{ij})M_j.$$

For all i and j :

$$y_{ij} = 0 \text{ or } 1$$

In explicit form, the LINGO model is:

```

MODEL:
SETS:
  MARKET/B, L, E, H/:S, N;
  ITEM/NONE, SO, WO, BOTH/:X;
  CROSS(MARKET, ITEM):R, Y, P;
ENDSETS
DATA:
  N = 7, 5, 6, 4.5;
  R = 0 450 110 530
      0 75 430 480
      0 290 250 410
      0 220 380 390;
ENDDATA

```



```

MAX = @SUM(CROSS(I, J): P(I, J) * N(I));
!Make the PICK variables 0/1;
@FOR(CROSS:@BIN(PICK));
!Each customer buys exactly one bundle;
@FOR(MARKET(I): @SUM(ITEM(J): Y(I, J)) = 1);
!Each customer's achieved surplus, SURP, must be at
  least as good from every possible bundle;
@FOR(ITEM(I): @FOR(MARKET(J): X(I) + S(J)
  >= R(J, I)));
!Compute the achieved surplus;
@FOR(MARKET(I): @SUM(ITEM(J): P(I, J)
  - R(I, J) * Y(I, J)) + S(I) = 0);
! Each product variable Pij must be.. ;
!   <= Xj ;
!   <= Rij * Yij ;
!   >= Xj   M + M * Yij ;
M = 600; !Max price of any bundle;
@FOR(CROSS(I, J): P(I, J) <= X(J);
  P(I, J) <= Y(I, J) * R(I, J);
  R(I, J) >= X(J) - M + M * Y(I, J));
! Price of bundle should be < sum of component
  prices;
X(BOTH) <= X(SO) + X(WO);
! Price of bundle should be > any one component;
X(BOTH) >= X(SO); X(BOTH) >= X(WO);
END

```

For the Microland problem, the solution is to set the following prices:

	Spreadsheet Only	Word Processing Only	Both
Bundle Price:	410	380	410

Thus, the business, legal and educational markets will buy the bundle of both products. The home market will buy only the word processor. Total revenues obtained by Microland are 90,900,000. The interested reader may show that, if bundling is not possible, then the highest revenue that Microland can achieve is only 67,150,000.

11.9 Representing Logical Conditions

For some applications, it may be convenient, perhaps even logical, to state requirements using logical expressions. A logical variable can take on only the values TRUE or FALSE. Likewise, a logical expression involving logical variables can take on only the values TRUE or FALSE. There are two major logical operators, .AND. and .OR., that are useful in logical expressions.

The logical expression:

$$A \text{ .AND. } B$$

is TRUE if and only if both A and B are true.

The logical expression:

$$A \text{ .OR. } B$$

is TRUE if and only if at least one of A and B is true.

It is sometimes useful also to have the logical operator implication (\Rightarrow) written as follows:

$$A \Rightarrow B$$

with the meaning that if A is true, then B must be true.

Logical variables are trivially representable by binary variables with:

TRUE being represented by 1, and
FALSE being represented by 0.

If A , B , and C are 0/1 variables, then the following constraint combinations can be used to represent the various fundamental logical expressions:

Logical Expression	Mathematical Constraints
$C = A \text{ .AND. } B$	$C \leq A$ $C \leq B$ $C \geq A + B - 1$
$C = A \text{ .OR. } B$	$C \geq A$ $C \geq B$ $C \leq A + B$
$A \Rightarrow C$	$A \leq C$

11.10 Problems

- The following problem is known as a segregated storage problem. A feed processor has various amounts of four different commodities, which must be stored in seven different silos. Each silo can contain at most one commodity. Associated with each commodity and silo combination is a loading cost. Each silo has a finite capacity, so some commodities may have to be split over several silos. For a similar problem arising in the loading of fuel tank trucks at Mobil Oil Company, see Brown, Ellis, Graves, and Ronen (1987). The following table contains the data for this problem.

Loading Cost per Ton								
Commodity	Silo							Amount of Commodity To Be Stored
	1	2	3	4	5	6	7	
A	\$1	\$2	\$2	\$3	\$4	\$5	\$5	75 tons
B	2	3	3	3	1	5	5	50 tons
C	4	4	3	2	1	5	5	25 tons
D	1	1	2	2	3	5	5	80 tons
Silo Capacity in Tons	25	25	40	60	80	100	100	

- a) Present a formulation for solving this class of problems.
 - b) Find the minimum cost solution for this particular example.
 - c) How would your formulation change if additionally there was a fixed cost associated with each silo that is incurred if anything is stored in the silo?
2. You are the scheduling coordinator for a small, growing airline. You must schedule exactly one flight out of Chicago to each of the following cities: Atlanta, Los Angeles, New York, and Peoria. The available departure slots are 8 A.M., 10 A.M., and 12 noon. Your airline has only two departure lounges, so at most two flights can be scheduled per slot. Demand data suggest the following expected profit contribution per flight as a function of departure time:

Expected Profit Contribution in \$1000's

Destination	Time		
	8	10	12
Atlanta	10	9	8.5
Los Angeles	11	10.5	9.5
New York	17	16	15
Peoria	6.4	2.5	-1

Formulate a model for solving this problem.

3. A problem faced by an electrical utility each day is that of deciding which generators to start up at which hour based on the forecast demand for electricity each hour. This problem is also known as the unit commitment problem. The utility in question has three generators with the following characteristics:

Generator	Fixed Startup Cost	Fixed Cost per Period of Operation	Cost per Period per Megawatt Used	Maximum Capacity in Megawatts Each Period
A	3000	700	5	2100
B	2000	800	4	1800
C	1000	900	7	3000

There are two periods in a day and the number of megawatts needed in the first period is 2900. The second period requires 3900 megawatts. A generator started in the first period may be used in the second period without incurring an additional startup cost. All major generators (e.g., *A*, *B*, and *C* above) are turned off at the end of each day.

- a) First, assume fixed costs are zero and thus can be disregarded. What are the decision variables?
- b) Give the LP formulation for the case where fixed costs are zero.
- c) Now, take into account the fixed costs. What are the additional (zero/one) variables to define?
- d) What additional terms should be added to the objective function? What additional constraints should be added?

4. *Crude Integer Programming.* Recently, the U.S. Government began to sell crude oil from its Naval Petroleum Reserve in sealed bid auctions. There are typically six commodities or products to be sold in the auction, corresponding to the crude oil at the six major production and shipping points. A “bid package” from a potential buyer consists of (a) a number indicating an upper limit on how many barrels (bbl.) the buyer is willing to buy overall in this auction and (b) any number of “product bids”. Each product bid consists of a product name and three numbers representing, respectively, the bid price per barrel of this product, the minimum acceptable quantity of this product at this price, and the maximum acceptable quantity of this product at this price. Not all product bids of a buyer need be successful. The government usually places an arbitrary upper limit (e.g., 20%) on the percentage of the total number of barrels over all six products one firm is allowed to purchase.

To illustrate the principal ideas, let us simplify slightly and suppose there are only two supply sources/products, which are denoted by A and B . There are 17,000 bbls. available at A while B has 13,000. Also, there are only two bidders, the Mobon and the Exxil companies. The government arbitrarily decides either one can purchase at most 65% of the total available crude. The two bid packages are as follows:

Mobon:

Maximum desired = 16,000 bbls. total.

Product	Bid per Barrel	Minimum Barrels Accepted	Maximum Barrels Wanted
A	43	9000	16,000
B	51	6000	12,000

Exxil:

Maximum desired = No limit.

Product	Bid per Barrel	Minimum Barrels Accepted	Maximum Barrels Wanted
A	47	5000	10,000
B	50	5000	10,000

Formulate and solve an appropriate IP for the seller.

5. A certain state allows a restricted form of branch banking. Specifically, a bank can do business in county i if the bank has a “principal place of business” in county i or in a county sharing a nonzero-length border with county i . Figure 11.9 is a map of the state in question:

Figure 11.9 Districts in a State

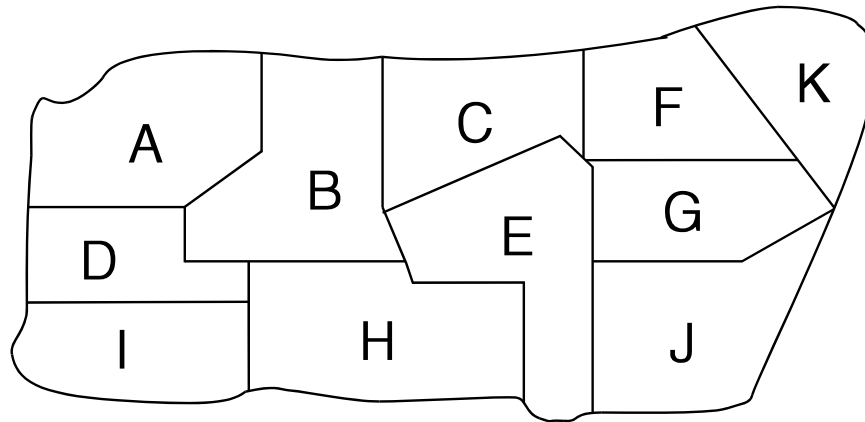

Formulate the problem of locating a minimum number of principal places of business in the state, so a bank can do business in every county in the state. If the problem is formulated as a covering problem, how many rows and columns will it have? What is an optimal solution? Which formulation is tighter: set covering or simple plant location?

6. *Data Set Allocation Problem.* There are 10 datasets or files, each of which is to be allocated to 1 of 3 identical disk storage devices. A disk storage device has 885 cylinders of capacity. Within a storage device, a dataset will be assigned to a contiguous set of cylinders. Dataset sizes and interactions between datasets are shown in the table below. Two datasets with high interaction rates should not be assigned to the same device. For example, if datasets C and E are assigned to the same disk, then an interaction cost of 46 is incurred. If they are assigned to different disks, there is no interaction cost between C and E .

Dataset for Interaction (Seek Transition) Rates

	A	B	C	D	E	F	G	H	I	J	Dataset Size in Cylinders
A											110
B	43										238
C	120	10									425
D	57	111	188								338
E	96	78	46	88							55
F	83	58	421	60	63						391
G	77	198	207	109	73	74					267
H	31	50	43	47	51	21	88				105
I	38	69	55	21	36	391	47	96			256
J	212	91	84	53	71	40	37	35	221		64
											2249

Find an assignment of datasets to disks, so total interaction cost is minimized and no disk capacity is exceeded.

7. The game or puzzle of mastermind pits two players, a “coder” and a “decoder”, against each other. The game is played with a pegboard and a large number of colored pegs. The pegboard has an array of 4×12 holes. For our purposes, we assume there are only six colors: red, blue, clear, purple, gold, and green. Each peg has only one color. The coder starts the game by selecting four pegs and arranging them in a fixed order, all out of sight of the decoder. This ordering remains fixed throughout the game and is appropriately called the code. At each play of the game, the decoder tries to match the coder’s ordering by placing four pegs in a row on the board. The coder then provides two pieces of information about how close the decoder’s latest guess is to the coder’s order:
- 1) The number of pegs in the correct position (i.e., color matching the coder’s peg in that position), and
 - 2) The maximum number of pegs that would be in correct position if the decoder were allowed to permute the ordering of the decoder’s latest guess.

Call these two numbers m and n . The object of the decoder is to discover the code in a minimum number of plays.

The decoder may find the following IP of interest.

```

MAX = XRED1;
  XRED1 + XBLUE1 + XCLEAR1 + XPURP1 + XGOLD1
    + XGREEN1 = 1;
  XRED2 + XBLUE2 + XCLEAR2 + XPURP2 + XGOLD2
    + XGREEN2 = 1;
  XRED3 + XBLUE3 + XCLEAR3 + XPURP3 + XGOLD3
    + XGREEN3 = 1;
  XRED4 + XBLUE4 + XCLEAR4 + XPURP4 + XGOLD4
    + XGREEN4 = 1;
  XRED1 + XRED2 + XRED3 + XRED4 - RED = 0;
  XBLUE1 + XBLUE2 + XBLUE3 + XBLUE4 - BLUE = 0;
  XCLEAR1 + XCLEAR2 + XCLEAR3 + XCLEAR4 - CLEAR = 0;
  XPURP1 + XPURP2 + XPURP3 + XPURP4 - PURP = 0;
  XGOLD1 + XGOLD2 + XGOLD3 + XGOLD4 - GOLD = 0;
  XGREEN1 + XGREEN2 + XGREEN3 + XGREEN4 - GREEN = 0;
END

```

All variables are required to be integer. The interpretation of the variables is as follows. $XRED1 = 1$ if a red peg is in position 1, otherwise 0, etc.; $XGREEN4 = 1$ if a green peg is in position 4, otherwise 0. Rows 2 through 5 enforce the requirement that exactly one peg be placed in each position. Rows 6 through 11 are simply accounting constraints, which count the number of pegs of each color. For example, RED = the number of red pegs in any position 1 through 4. The objective is unimportant. All variables are (implicitly) required to be nonnegative.

At each play of the game, the decoder can add new constraints to this IP to record the information gained. Any feasible solution to the current formulation is a reasonable guess for the next play. An interesting question is what constraints can be added at each play.

To illustrate, suppose the decoder guesses the solution $XBLUE1 = XBLUE2 = XBLUE3 = XRED4 = 1$, and the coder responds with the information that $m = 1$ and $m - n = 1$. That is, one peg is in the correct position and, if permutations were allowed, at most two pegs would be in the correct position. What constraints can be added to the IP to incorporate the new information?

8. The Mathematical Football League (MFL) is composed of M teams (M is even). In a season of $2(M - 1)$ consecutive Sundays, each team will play $(2M - 1)$ games. Each team must play each other team twice, once at home and once at the other team's home stadium. Each Sunday, k games from the MFL are televised. We are given a matrix $\{v_{ij}\}$ where v_{ij} is the viewing audience on a given Sunday if a game between teams i and j playing at team j 's stadium is televised.
 - a) Formulate a model for generating a schedule for the MFL that maximizes the viewing audience over the entire season. Assume viewing audiences are additive.
 - b) Are some values of k easier to accommodate than others? How?

9. The typical automobile has close to two dozen electric motors. However, if you examine these motors, you will see that only about a half dozen distinct motor types are used. For inventory and maintenance reasons, the automobile manufacturer would like to use as few distinct types as possible. For cost, quality, and weight reasons, one would like to use as many distinct motor types as possible, so the most appropriate motor can be applied to each application. The table below describes the design possibilities for a certain automobile:

24-Month Failure Probability						
Application	Number Required	Motor type				
		A	B	C	D	E
Head lamps	2	0.002	0.01		0.01	0.007
Radiator fan	2		0.01	0.002		0.004
Wipers	2				0.007	
Seat	4	0.003			0.006	0.008
Mirrors	2			0.004	0.001	
Heater fan	1		0.006	0.001		
Sun roof	1	0.002			0.003	0.009
Windows	4	0.004	0.008	0.005		
Antenna	1	0.003		0.003	0.002	
	Weight	2	3	1.5	1	4
	Cost per Motor	24	20	36	28	39

For example, two motors are required to operate the headlamps. If type *D* motors are used for headlamps, then the estimated probability of a headlamp motor failure in two years is about 0.01. If no entry appears for a particular combination of motor type and application, it means the motor type is inappropriate for that application (e.g., because of size).

Formulate a solvable linear integer program for deciding which motor type to use for each application, so at most 3 motor types are used, the total weight of the motors used is at most 36, total cost of motors used is at most 585, and probability of any failure in two years is approximately minimized.

10. We have a rectangular three-dimensional container that is $30 \times 50 \times 50$. We want to pack in it rectangular three-dimensional boxes of the three different sizes: (a) $5 \times 5 \times 10$, (b) $5 \times 10 \times 10$, and (c) $5 \times 15 \times 25$.

A particular packing of boxes into the container is undominated if there is no other packing that contains at least as many of each of the three box types and strictly more of one of the box types.

Show there are no more than 3101 undominated packings.

11. Given the following:

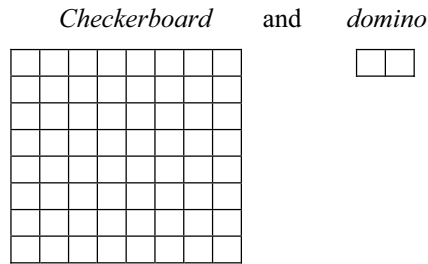

If two opposite corners of the checkerboard are made unavailable, prove there is no way of exactly covering the remaining grid with 31 dominoes.

12. Which of the following requirements could be represented exactly with linear constraints? (You are allowed to use transformations if you wish.)
- $(3 \times x + 4 \times y) / (2 \times x + 3 \times y) \leq 12$;
 - $\text{MAX}(x, y) < 8$;
 - $3 \times x + 4 \times y \times y \geq 11$; where y is 0 or 1;
 - $\text{ABS}(10 - x) \leq 7$ (Note ABS means absolute value);
 - $\text{MIN}(x, y) < 12$.
13. A common way of controlling access in many systems, such as information systems or the military, is with priority levels. Each user i is assigned a clearance level U_i . Each object j is assigned a security level L_j . A user i does not have access to object j if the security level of j is higher than the clearance level of i . Given a set of users; and, for each user, a list of objects to which that user does not to have access; and a list of objects to which the user should have access, can we assign U_i 's and L_j 's, so these access rights and denials are satisfied? Formulate as an integer program.
14. One of the big consumption items in the U.S. is automotive fuel. Any petroleum distributor who can deliver this fuel reliably and efficiently to the hundreds of filling stations in a typical distribution region has a competitive advantage. This distribution problem is complicated by the fact that a typical customer (i.e., filling station) requires three major products: premium gasoline, an intermediate octane grade (e.g., "Silver"), and regular gasoline. A typical situation is described below. A delivery tank truck has four compartments with capacities in liters of 13,600, 11,200, 10,800, and 4400. We would like to load the truck according to the following limits:

	Liters of		
	Premium	Intermediate	Regular
At least:	8,800	12,000	12,800
At most:	13,200	17,200	16,400

Only one gasoline type can be stored per compartment in the delivery vehicle. Subject to the previous considerations, we would like to maximize the amount of fuel loaded on the truck.

- Define the decision variables you would use in formulating this problem as an IP.
- Give a formulation of this problem.
- What allocation do you recommend?

15. Most lotteries are of the form:

Choose n numbers (e.g., $n = 6$) from the set of numbers $\{1, 2, \dots, m\}$ (e.g., $m = 54$).

You win the grand prize if you buy a ticket and choose a set of n numbers identical to the n numbers eventually chosen by lottery management. Smaller prizes are awarded to people who match k of the n numbers. For $n = 6$, typical values for k are 4 and 5. Consider a modest little lottery with $m = 7$, $n = 3$, and $k = 2$. How many tickets would you have to buy to guarantee winning a prize? Can you set this up as a grouping/covering problem?

16. A recent marketing phenomenon is the apparent oxymoron, “mass customization”. The basic idea is to allow each customer to design his/her own product, and yet do it on an efficient, high-volume scale. A crucial component of the process is to automate the final design step involving the customer. As an example, IBM and Blockbuster recently announced a plan to offer “on-demand” production of customized music products at retail stores. Each store would carry an electronic “master” for every music piece a customer might want. The physical copy for the customer would then be produced for the customer while they wait. This opens up all manners of opportunities for highly customized musical products. Each customer might provide a list of songs to be placed on an audiocassette. A design issue when placing songs on a two-sided medium such as a cassette is how to allocate songs to sides. A reasonable rule is to distribute the songs, so the playing times on the two sides are as close to equal as possible. For an automatic tape player, this will minimize the “dead time” when switching from one side to another. As an example, we mention that Willie Nelson has recorded the following ten songs in duets with other performers:

Song	Time (min:secs)	Other Performer
1) Pancho and Lefty	4:45	Merle Haggard
2) Slow Movin Outlaw	3:35	Lacy J. Dalton
3) Are There any More Real Cowboys	3:03	Neil Young
4) I Told a Lie to My Heart	2:52	Hank Williams
5) Texas on a Saturday Night	2:42	Mel Tillis
6) Seven Spanish Angels	3:50	Ray Charles
7) To All the Girls I've Loved Before	3:30	Julio Iglesias
8) They All Went to Mexico	4:45	Carlos Santana
9) Honky Tonk Women	3:30	Leon Russell
10) Half a Man	3:02	George Jones

You want to collect these songs on a two-sided tape cassette album to be called “Half Nelson.”

- Formulate and solve an integer program for minimizing the dead time on the shorter side.
- What are some of the marketing issues of allowing the customer to decide which song goes on which side?

17. Bill Bolt is hosting a party for his daughter Lydia on the occasion of her becoming of college age. He has reserved a banquet room with 18 tables at the Racquet Club on Saturday night. Each table can accommodate at most 8 people. A total of 140 young people are coming, 76 young men and 64 young ladies. Lydia and her mother, Jane, would like to have the sexes as evenly distributed as possible at the tables. They want to have at least 4 men and at least 3 women at each table.
- Is it possible to have an allocation satisfying the above as well as the restriction there be at most 4 men at each table?
 - Provide a good allocation of the sexes to the tables.
18. The game or puzzle of Clue is played with a deck of 21 cards. At the beginning of a game, three of the cards are randomly selected and placed face down in the center of the table. The remaining cards are distributed face down as evenly as possible to the players. Each player may look at his or her own cards. The object of the game is to correctly guess the three cards in the center. At each player's turn, the player is allowed to either guess the identity of the three cards in the center or ask any other player a question of the form: "Do you have any of the following three cards?" (The asking player then publicly lists the three cards.) If the asked player has one of the three identified cards, then the asked player must show one of the cards to the asking player (and only to the asking player). Otherwise, the asked player simply responds "No". If a player correctly guesses the three cards in the center, then that player wins. If a player incorrectly guesses the three cards in the center, the player is out of the game.

Deductions about the identity of various cards can be made if we define:

$$X(i, j) = 1 \text{ if player } i \text{ has card } j, \text{ else } 0.$$

Arbitrarily define the three cards in the center as player 1. Thus, we can initially start with the constraints:

$$\sum_{j=1}^{21} X(1, j) = 3.$$

For each card, $j = 1, 2, \dots, 21$:

$$\sum_i X(i, j) = 1.$$

- Suppose player 3 is asked: "Do you have either card 4, 8, or 17?" and player 3 responds "No." What constraint can be added?
- Suppose in response to your question in (a), player 3 shows you card 17. What constraint can be added?
- What LP would you solve in order to determine whether card 4 must be one of the cards in the center?

Note, in the "implementation" of the game marketed in North America, the 21 cards are actually divided into three types: (i) six suspect cards with names like "Miss Scarlet," (ii) six weapons cards with names like "Revolver," and (c) nine room cards with names like "Kitchen." This has essentially no effect on our analysis above.

Decision making Under Uncertainty and Stochastic Programs

If you come to a fork in the road, take it.
-Y. Berra

12.1 Introduction

The main reason multiperiod planning is difficult is because of uncertainty about the future. Typically, some action or decision must be taken today, which somehow strikes a compromise between the actions that would be, in retrospect, best for each of the possible “futures”. For example, next year, if the demand for your new product proves to be large and the cost of raw material increases markedly, then buying a lot of raw material today would win you a lot of respect next year as a wise and perceptive manager. On the other hand, if the market disappears for both your product and your raw material, the company stockholders would probably not be so kind as to call your purchase of lots of raw material bad luck.

12.2 Identifying Sources of Uncertainty

In a discussion with the author, the chief financial officer of a large petroleum company made the comment: “The trouble with you academics is that you assume the probabilities add up to one. In the real world, they do not. You may think the possible outcomes are: ‘hit oil’, ‘hit gas’, or ‘dry hole’. In reality, the drilling rig catches fire and causes a major disaster.” The point of the comment is that an important part of managing uncertainty is identifying as many sources of uncertainty as possible. The following is a typical list with which to start:

1. Weather related:
 - decisions about how much and where to stockpile supplies of fuel and road salt in preparation for the winter;
 - water release decisions in the spring for a river and dam system, taking into account hydroelectric, navigation, and flooding considerations.

2. Financial uncertainty:
 - market price movements (e.g., stock price, interest rate, and foreign exchange rate movements);
 - defaults by business partner (e.g., bankruptcy of a major customer).
3. Political events:
 - changes of government;
 - outbreaks of hostilities.
4. Technology related:
 - whether a new technology is useable by the time the next version of a product is scheduled to be released.
5. Market related:
 - shifts or fads in tastes;
 - population shifts.
6. Competition:
 - the kinds of strategies used by the competition next year.
7. Acts of God:
 - hurricane, tornado, earthquake, or fire;
 - equipment failure.

In an analysis of a decision under uncertainty, we would proceed through a list such as the above and identify those items that might interact with our decision. Weather, in particular, can be a big source of uncertainty. Hidroeléctrica Española, for example (see Dembo et al. (1990)), reports available power output per year from one of its hydroelectric facilities varied from 8,350 Gwh (Giga-watt-hours) to 2,100 Gwh over a three-year period simply because of rainfall variation.

Methods very similar to those described here have been used in the automotive industry to make plant opening and closing decisions in the face of uncertainty about future demand. These methods have also been used in the utilities industry to make fuel purchase decisions in the face of uncertainties about weather in the next few years.

12.3 The Scenario Approach

We will start by considering planning problems with two periods. These situations consist of the following sequence of events:

- 1) We make a first-period decision.
- 2) Nature (frequently known as the marketplace) makes a random decision.
- 3) We make a second-period decision that attempts to repair the havoc wrought by nature in (2).

The scenario approach assumes there are a finite number of decisions nature can make. We call each of these possible states of nature a “scenario”. For example, in practice, most people are satisfied with classifying demand for a product as being low, medium, or high; or classifying a winter as being severe, normal, or mild, rather than requiring a statement of the average daily temperature and total snowfall measured to six decimal places. General Motors has historically used low, medium, and high scenarios to represent demand uncertainty. The type of model we will describe for representing uncertainty in the context of LPs is called a “stochastic program”. For a survey of applications and methodology, see Birge (1997). For an extensive introduction to stochastic programming ideas, see Kall and Wallace (1994). For a good discussion of some of the issues in applying stochastic programming to financial decisions, see Infanger (1994).

The first example analyzes a situation in which only steps (1) and (2) are important. A farmer can plant his land to either corn, sorghum, or beans. He is willing to classify the growing season as being either wet or dry. For simplicity, assume the season will be either wet or dry, nothing in between. If it is wet, then corn is more profitable. Otherwise, beans are more profitable. The specifics are listed in the table below:

		Profit/Acre as a Function of Decisions		
		Our Decision		
Nature's Decision		All Corn	All Sorghum	All Beans
	Wet		\$100	\$70
Dry		-\$10	\$40	\$35

In step (1), the farmer decides upon how much to plant of each crop. In step (2), nature decides if the season is wet or dry. Step (3) is trivial. The farmer simply enjoys his profit or suffers his losses.

There is no scenario in which beans are the best crop. You might be tempted to eliminate beans from further consideration. However, we shall see this could be wrong.

A situation in which there are exactly two possible decisions by nature can be fruitfully analyzed by the kind of graph appearing in Figure 12.1:

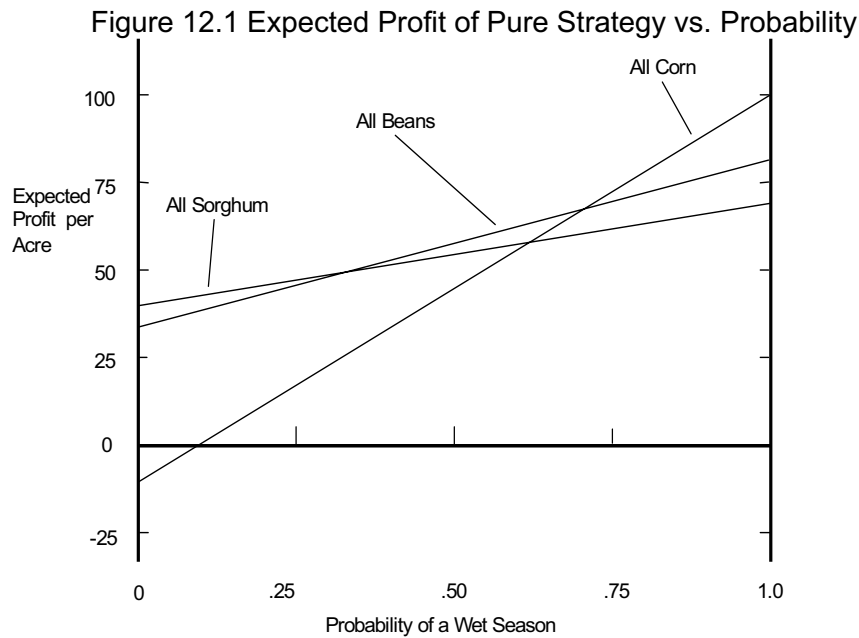

The three lines specify expected profit for a given pure policy (all corn, all sorghum, or all soybeans) as a function of the probability of a wet season. If the probability of a wet season is p , then the expected profit for various crops is:

	Corn	Sorghum	Beans
Expected Profit	$-10 + 110p$	$40 + 30p$	$35 + 45p$

Assuming expected profit is to be maximized, we are indifferent between sorghum and beans when $p = 1/3$. We are indifferent between beans and corn when $p = 9/13$. Thus, if the probability of a

wet season is judged to be less than $1/3$, then all sorghum should be planted. If we feel p is greater than $9/13$, then all corn should be planted. If $1/3 < p < 9/13$, then all beans should be sown. All of this assumes the farmer is risk neutral and is interested only in maximizing expected profits. It is important to note that, if the farmer is an expected profit maximizer, then the optimal strategy is a pure one: he either plants all corn, all beans, or all sorghum.

An approach one might be tempted to use is to solve for the optimal first-stage decision for each of the possible decisions of nature. Then, implement a first-stage decision that is a weighted average of the “conditionally optimal” decisions. For this example, the optimal decision, if we know nature’s decision is “wet”, is to plant all corn; whereas, planting all sorghum is optimal if we know beforehand the season will be dry. Suppose the probability of a wet season is $3/8$. Then, the “weighted” decision is to plant $3/8$ of the acreage in corn and $5/8$ in sorghum. The expected profit per acre is $(3/8)[(3/8)100 + (5/8)70] + (5/8)[(3/8)(-10) + (5/8)40] = \43.75 .

This should be contrasted with the decision that maximizes the expected profit. For a probability of a wet season equal to $3/8$, the expected profit of planting all soybeans is $(3/8)80 + (5/8)35 = \$51.875$ per acre. The expected profit from behaving optimally is almost 20% greater than just behaving “reasonably”. The qualitative conclusion to draw from this small example is:

The best decision for today, when faced with a number of different outcomes for the future, is in general not equal to the “average” of the decisions that would be best for each specific future outcome.

For a problem this simple, one does not need LP. However, let us demonstrate the LP for this problem in preparation for more complex problems. There are three first-stage decision variables:

C = acreage planted to corn,
 S = acreage planted to sorghum,
 B = acreage planted to beans.

Presuming the probability of a wet season is $3/8$, the objective is to:

Maximize $(3/8)(100C + 70S + 80B) + (5/8)(-10C + 40S + 35B)$
 subject to $C + S + B \leq 1$

The solitary constraint specifies that we are interested only in how to plant one acre. When the expressions in the objective are calculated and simplified, we get:

Maximize $31.25 C + 51.25 S + 51.875 B$
 subject to $C + S + B \leq 1$.

The solution is clearly to set $B = 1$ (i.e., plant all beans).

The coefficients of corn and sorghum in the objective are simply the expected profits of planting one acre of the respective crop.

12.4 A More Complicated Two-Period Planning Problem

The previous example had a trivial second-stage decision. There were no decisions left to be made after nature made its decision. The following example requires some non-trivial second-stage decisions.

It is late summer in a northern city and the director of streets is making decisions regarding the purchase of fuel and salt to be used in snow removal in the approaching winter. If insufficient supplies are purchased before a severe winter, substantially higher prices must be paid to purchase these

supplies quickly during the winter. There are two methods of snow removal: plowing or salting. Salting is generally cheaper, especially during a warm winter. However, excess salt after a warm winter must be carried until next winter. On the other hand, excess fuel is readily usable by other city departments, so there is less penalty for stocking too much fuel.

The director of streets classifies a winter as either warm or cold and attaches probabilities 0.4 and 0.6, respectively, to these two possible states of nature. The costs and salvage values of salt and fuel are described in the table below. Decisions made before winter are period 1 decisions; whereas, decisions made during or after winter are period 2 decisions. For the convenience of the reader, all figures will be presented in “truck-days”. That is, the amount consumed by one truck in one day:

Cost or Value of Supplies vs. Date of Purchase				
		Salt	Fuel	Cost per Truck-Day
Bought In Period 1		\$20	\$70	
	Warm	\$30	\$73	\$110
Bought in Period 2				
	Cold	\$32	\$73	\$120
Salvage Value at End of Period 2		\$15	\$65	

Notice the second-period price of salt is a random variable depending upon the weather. If the winter is cold, we expect the price of salt to be higher.

The cost of operating a truck per day, exclusive of fuel and salt, is \$110 in a warm winter, but \$120 in a cold winter. The truck fleet has a capacity of 5,000 truck-days during the winter season. If only plowing is used, then a warm winter will require 3,500 truck-days of snow removal; whereas, a cold winter will require 5,100. Salting is a more effective use of trucks than plowing. In a warm winter, one truck salting is equivalent to 1.2 trucks plowing; whereas, in a cold winter, the equivalency drops to 1.1. Thus, in a cold winter, the limited truck capacity implies some salting will be necessary.

At this point, it is useful to define variables for the amounts of fuel and salt bought or sold at various times:

- BF1 = truck-days of fuel bought in period 1
- BS1 = truck-days of salt bought in period 1
- BFW = fuel bought in period 2, warm winter
- BSW = salt bought in period 2, warm winter
- XFW = excess fuel at end of warm winter
- XSW = excess salt at end of warm winter
- PW = truck-days plowing, warm winter
- SW = truck-days spreading salt, warm winter
- KW = costs incurred during a warm winter in dollars
- BFC = fuel bought in period 2, cold winter
- BSC = salt bought in period 2, cold winter
- XFC = excess fuel at end of a cold winter
- XSC = excess salt at end of a cold winter
- PC = truck-days plowing, cold winter
- SC = truck-days spreading salt, cold winter
- KC = costs incurred during a cold winter in dollars

An important thing to notice is that we have defined unique second-stage decision variables for each of the possible states of nature (e.g., salt bought in period 2 is distinguished as to whether bought in a warm rather than a cold winter). This is the key to constructing a correct formulation.

12.4.1 The Warm Winter Solution

If the winter is known to be warm, then the relevant LP is:

```

MIN = 70 * BF1 + 20 * BS1 + KW;
-BF1 - BFW + XFW + PW + SW = 0;           !(Fuel Usage);
-BS1 - BSW + XSW + SW = 0;               !(Salt Usage);
PW + SW < 5000;                          !(Truck Usage);
PW + 1.2 * SW > 3500;                     !(Snow Removal);
KW - 73*BFW - 30*BSW + 65*XFW + 15*XSC !(Cost);
- 110 * PW - 110 * SW = 0;

```

When solved, the solution is:

```

Objective value: 583333.3
Variable      Value      Reduced Cost
BF1           2916.667      0.0000000
BS1           2916.667      0.0000000
KW            320833.3      0.0000000
BFW           0.0000000      3.0000000
XFW           0.0000000      5.0000000
PW            0.0000000      13.33334
SW            2916.667      0.0000000
BSW           0.0000000      10.00000
XSW           0.0000000      5.00000
Row           Slack or Surplus      Dual Price
1              583333.3          1.0000000
2              0.0000000          70.00000
3              0.0000000          20.00000
4              2083.333           0.0000000
5              0.0000000          -166.6667
6              0.0000000          -1.0000000

```

The solution is as you would expect if you knew beforehand the winter is to be warm: buy sufficient fuel and salt in the first period to follow a “pure salt spreading” policy in the second period. No supplies are bought, nor is there any excess in period 2.

12.4.2 The Cold Winter Solution

The corresponding LP, if we knew the winter would be cold, is:

```

MIN = 70 * BF1 + 20 * BS1 + KC;
-BF1 - BFC + XFC + PC + SC = 0;
-BS1 + SC - BSC + XSC = 0;
PC + SC <= 5000;
PC + 1.1 * SC >= 5100;
KC - 73 * BFC + 65 * XFC - 120 * PC - 120 * SC - 32 * BSC + 15 *
XSC=0;

```

Here is a sets formulation of the above model:

```
SETS:
  COLD/BF1, BS1, BFC, BSC, XFC, XSC, PC, SC, KC/:
  QTY, FUEL, SALT, COST1, COST2, SALV, TRUCKVAL,
  PLOWVAL;
ENDSETS
DATA:
  COST1 = 70 20 0 0 0 0 0 0 0 1;
  FUEL = -1 0 -1 0 1 0 1 1 0;
  SALT = 0 -1 0 -1 0 1 0 1 0;
  TRUCKVAL = 0 0 0 0 0 0 1 1 0;
  PLOWVAL = 0 0 0 0 0 0 1 1.1 0;
  COST2 = 0 0 -73 -32 65 15 -120 -120 1;
ENDDATA
  MIN = @SUM( COLD( I): QTY * COST1);
  @SUM( COLD( I): QTY * FUEL) = 0;
  @SUM( COLD( I): QTY * SALT) = 0;
  @SUM( COLD( I): TRUCKVAL * QTY) <= 5000;
  @SUM( COLD( I): PLOWVAL * QTY) >= 5100;
  @SUM( COLD( I): COST2 * QTY) = 0;
```

The solution is slightly more complicated. In a cold winter, the assumptions are such as to make plowing slightly more cost effective than salting. A pure plowing policy cannot be used, however, because of scarce truck capacity. Thus, just sufficient salt is used to make the truck capacity sufficient. This is illustrated below:

```
Optimal solution found at step:      6
Objective value:                    970000.0
```

Variable	Value	Reduced Cost
BF1	5000.000	0.0000000
BS1	1000.000	0.0000000
KC	600000.0	0.0000000
BFC	0.0000000	3.0000000
XFC	0.0000000	5.0000000
PC	4000.000	0.0000000
SC	1000.000	0.0000000
BSC	0.0000000	12.0000000
XSC	0.0000000	5.0000000
Row	Slack or Surplus	Dual Price
1	970000.0	1.0000000
2	0.0000000	70.0000000
3	0.0000000	20.0000000
4	0.0000000	10.0000000
5	0.0000000	-200.0000000
6	0.0000000	-1.0000000

12.4.3 The Unconditional Solution

Neither of these two models or solutions, however, are immediately useful by themselves, because it is not known beforehand whether it will be a cold or warm winter. Part of the problem is the two solutions recommend different first-period purchasing decisions depending upon whether the winter is to be warm or cold. In reality, the first-period decision must be unique, regardless of whether the

winter is cold or warm. This is easy to remedy, however. We simply combine the two models into one. Because the same first-stage variables, *BF1* and *BS1*, appear in both sets of constraints, this forces the same first-stage decision to appear regardless of the severity of the winter.

It remains to specify the appropriate objective function for the combined problem. It is obvious the cost coefficients of the first-stage variables are appropriate as is. However, the second-stage costs, *KW* and *KC*, are really random variables. With probability 0.4, we want *KW* to apply and *KC* to be treated as zero; whereas, with probability 0.6, we want *KC* to be in the objective and *KW* to be treated as zero. The correct resolution is to apply weights 0.4 and 0.6 to *KW* and *KC*, respectively, in the objective. Thus, the complete formulation is:

$$\begin{aligned}
 \text{MIN} &= 70 * \text{BF1} + 20 * \text{BS1} + .4 * \text{KW} + .6 * \text{KC}; \\
 -\text{BF1} - \text{BFW} + \text{XFW} + \text{PW} + \text{SW} &= 0; \\
 -\text{BS1} - \text{BSW} + \text{XSW} + \text{SW} &= 0; \\
 \text{PW} + \text{SW} &\leq 5000; \\
 \text{PW} + 1.2 * \text{SW} &\geq 3500; \\
 \text{KW} - 73 * \text{BFW} - 30 * \text{BSW} + 65 * \text{XFW} - 110 * \text{PW} - 110 * \text{SW} &= 0; \\
 -\text{BF1} - \text{BFC} + \text{XFC} + \text{PC} + \text{SC} &= 0; \\
 -\text{BS1} + \text{SC} - \text{BSC} + \text{XSC} &= 0; \\
 \text{PC} + \text{SC} &< 5000; \\
 \text{PC} + 1.1 * \text{SC} &\geq 5100; \\
 \text{KC} - 73 * \text{BFC} + 65 * \text{XFC} - 120 * \text{PC} - 120 * \text{SC} - 32 * \text{BSC} + 15 * \text{XSC} &= 0;
 \end{aligned}$$

In order to understand this model, it is worth looking at the following picture of its coefficients:

	B	B	B	X				B	X					B	X	R
	F	S	K	F	F	P	S	S	S	K	F	F	P	S	S	H
	1	1	W	W	W	W	W	W	W	C	C	C	C	C	C	S
1:	70	20	.4													MIN
2:	-1			-1	1	1	1									= 0
3:		-1						1	-1	1						= 0
4:					1	1										< 5000
5:					1	1.2										> 3500
6:			1-73	65-110	-110	-30	15									= 0
7:	-1									-1	1	1	1			= 0
8:		-1												1	-1	= 0
9:												1	1			< 5000
10:												1	1.1			> 5100
11:								1	-73	65-120	-120	-32	15			= 0

The model really consists of two submodels: one for a cold winter in the lower right and one for a warm winter above and to the left. These two models would be separate except for the linkage via the common first-stage variables *BF1* and *BS1* on the extreme left. Another way of stating the problem in words is:

Minimize First-stage cost + 0.4 (second-stage costs for a warm winter)
 + 0.6 (second-stage costs for a cold winter)
 subject to: The same first decisions applying regardless of whether the winter is warm or cold.

The solution to the complete problem is:

Optimal solution found at step:	12	
Objective value:	819888.3	
Variable	Value	Reduced Cost
BF1	2916.667	0.000000
BS1	2916.667	0.000000
KW	320833.3	0.000000
KC	715091.7	0.000000
BFW	0.000000	3.000000
XFW	0.000000	0.200004
PW	0.000000	4.683331
SW	2916.667	0.000000
BSW	0.000000	3.580000
XSW	0.000000	8.420000
BFC	1891.667	0.000000
XFC	0.000000	4.799998
PC	1891.667	0.000000
SC	2916.667	0.000000
BSC	0.000000	7.620001
XSC	0.000000	2.580000
Row	Slack or Surplus	Dual Price
1	819888.3	1.000000
2	0.000000	26.20000
3	0.000000	8.420000
4	2083.333	0.000000
5	0.000000	-65.51667
6	0.000000	-0.400000
7	0.000000	43.80000
8	0.000000	11.58000
9	191.6667	0.000000
10	0.000000	-115.8000
11	0.000000	-0.600000

The solution is interesting. It recommends buying sufficient salt and fuel in the first period to follow a pure salt spreading policy if the winter is warm. If the winter is cold, extra fuel is bought in the second period to be used for plowing only to gain the needed snow removal capacity. There will be no excess fuel or salt for either outcome.

We are now in position to state the general procedure for developing an LP model of a two-period planning problem under uncertainty:

For each possible state of nature, formulate the appropriate LP model.

Combine these submodels into one super model, making sure:

the first-stage variables are common to all submodels, but

the second-stage variables in a submodel appear only in that submodel.

The second-stage cost for each submodel appears in the overall objective function weighted by the probability nature will choose the state corresponding to that submodel.

In a typical application, there will be a debate about the proper values for the probabilities. Therefore, you may wish to examine the sensitivity of the results to changes in the probabilities. The range report below indicates some of these sensitivities:

Ranges in which the basis is unchanged:

Variable	Objective Coefficient Ranges		
	Current Coefficient	Allowable Increase	Allowable Decrease
BF1	70.00000	3.000000	0.2000008
BS1	20.00000	3.580000	8.420000
KW	0.4000000	0.3076935E-02	0.4109589E-01
KC	0.6000000	0.2739737E-02	0.4109589E-01
BFW	0.0	INFINITY	3.000000
XFW	0.0	INFINITY	0.2000004
PW	0.0	INFINITY	4.683331
SW	0.0	5.619992	78.62000
BSW	0.0	INFINITY	3.580000
XSW	0.0	INFINITY	8.420000
BFC	0.0	0.2000008	3.000000
XFC	0.0	INFINITY	4.799998
PC	0.0	6.927273	2.345454
SC	0.0	2.579999	7.620001
BSC	0.0	INFINITY	7.620001
XSC	0.0	INFINITY	2.580000

Row	Right-hand Side Ranges		
	Current RHS	Allowable Increase	Allowable Decrease
2	0.0	2916.667	1891.667
3	0.0	1916.667	1719.697
4	5000.000	INFINITY	2083.333
5	3500.000	2063.636	2300.000
6	0.0	INFINITY	320833.3
7	0.0	1891.667	INFINITY
8	0.0	1719.697	1916.667
9	5000.000	INFINITY	191.6667
10	5100.000	191.6667	1891.667
11	0.0	INFINITY	715091.7

Notice the objective coefficient ranges for *KW* and *KC* are quite small. Thus, it would appear modest changes in the probabilities, 0.4 and 0.6, might produce very noticeable changes in the solution.

12.5 Expected Value of Perfect Information (EVPI)

Uncertainty has its costs. Therefore, it may be worthwhile to invest in research to reduce the uncertainty. This investment might be in better weather forecasts for problems like the one just considered or it might be in test markets or market surveys for problems relating to new product investment. A bound on the value of better forecasts is obtainable by considering the possibility of getting perfect forecasts, so-called perfect information.

We have sufficient information on the snow removal problem to calculate the value of perfect information. For example, if we knew beforehand the winter would be warm, then we saw from the solution of the warm winter model the total cost would be \$583,333.3. On the other hand, if we knew beforehand that the winter would be cold, we saw the total cost would be \$970,000. Having perfect forecasts will not change the frequency of warm and cold winters. They will presumably still occur with respective probabilities 0.4 and 0.6. Thus, if we had perfect forecasts, the expected cost per season would be:

$$0.4 \times 583,333.3 + 0.6 \times 970,000 = 815,333.3$$

From the solution of the complete model, we see the expected cost per season without any additional information is \$819,888.3. Thus, the expected value of perfect information is $819,888.3 - 815,333.3 = \$4,555.0$. Therefore, if a well-dressed weather forecaster claims prior knowledge of the severity of the coming winter, then an offer of at most \$4,555 should be made to learn his forecast. We say the expected value of perfect information in this case is \$4,555. In reality, his forecast is probably worth considerably less because it is probably not a perfect forecast.

12.6 Expected Value of Modeling Uncertainty

Suppose the EVPI is high. Does this mean it is important to use stochastic programming, or the scenario approach? Definitely not. Even though the EVPI may be high, it may be a very simple deterministic model does just as well (e.g., recommends the same decision as a sophisticated stochastic model). The Expected Value of Modeling Uncertainty (EVMU) measures the additional profit possible by using a “correct” stochastic model. EVMU is always measured relative to some simpler deterministic model.

12.6.1 Certainty Equivalence

An interesting question is: are there some situations in which we know in advance $EVMU = 0$? A roughly equivalent question is: “Under what conditions can we replace a random variable in a model by its expected value without changing the action recommended by the model?” If we can justify such a replacement, then we have *a priori* determined that the EVMU is zero for that random variable. The following gives a sufficient condition:

Certainty Equivalence Theorem: If the randomness or unpredictability in problem data exists solely in the objective function coefficients, then it is correct to solve the LP in regular form after simply using the expected values for the random coefficients in the objective.

If the randomness exists in a right-hand side or a constraint coefficient, then it is not correct simply to replace the random element by its average or expected value. We can be slightly more precise if we define:

X = the set of decision variables,

Y_i = some random variable in the model,

\bar{Y}_i = all other random variables in the model, except Y_i ,

\tilde{Y}_i = all other random variables that are independent of Y_i .

We are justified in replacing Y_i by its expected value, $E(Y_i)$, if Y_i appears only in the objective function, and each term containing Y_i either:

- is not a function of X , or
- is linear in Y_i and contains no random variables dependent upon Y_i .

Equivalently, we must be able to write the objective as:

$$\text{Min } F_1(X, \bar{Y}_i) + F_2(X, \tilde{Y}_i) * Y_i + F_3(\bar{Y}_i, Y_i).$$

If we take expected values:

$$\begin{aligned} & E[F_1(X, \bar{Y}_i) + F_2(X, \tilde{Y}_i) * Y_i + F_3(\bar{Y}_i, Y_i)] \\ &= E[F_1(X, \bar{Y}_i)] + E[F_2(X, \tilde{Y}_i)] * E(Y_i) + E[F_3(\bar{Y}_i, Y_i)]. \end{aligned}$$

The third term is a constant with respect to the decision variables, so it can be dropped.

Thus, any X that minimizes $E[F_1(X, \bar{Y}_i) + F_2(X, \tilde{Y}_i) * Y_i]$ also minimizes:

$$E[F_1(X, \bar{Y}_i) + F_2(X, \tilde{Y}_i) * E(Y_i)].$$

As an example, consider a farmer who must decide how much corn, beans, and milo to plant in the face of random yields and random prices for the crops. Further, suppose the farmer receives a government subsidy that is a complicated function of current crop prices and the farmer's total land holdings, but not a function of current yield or planting decisions. Suppose the price for corn at harvest time is independent of the yield. The farmer's income can be written (income from beans and milo) + (acreage devoted to corn) \times (corn yield) \times (price of corn) + (subsidy based on prices).

The third term is independent of this year's decision, so it can be disregarded. In the middle term, the random variable, "price of corn", can be replaced by its expected value because it is independent of the two other components of the middle term.

12.7 Risk Aversion

Thus far, we have assumed the decision maker is strictly an expected profit maximizer and is neither risk averse nor risk preferring. Casino gamblers who play games such as roulette must be risk preferring if the roulette wheel is not defective, because their expected profits are negative. A person is risk averse if he or she attaches more weight to a large loss than expected profits maximization would dictate.

In the context of the snow removal problem, the Streets Manager might be embarrassed by a high cost of snow removal in a cold winter even though long run expected cost minimization would imply an occasional big loss. From the optimal policy for the snow removal problem, we can see the sum of first-period plus second-period costs if the winter is cold is:

$$70 * BF1 + 20 * BS1 + KC = 977591.$$

On the other hand, if it is known beforehand the winter will be cold, then we have seen this cost can be reduced to \$970,000.

For fear of attracting the attention of a political opponent, the Streets Manager might wish to prevent the possibility of a cost more than \$5,000 greater than the minimum possible for the cold winter outcome.

The Manager can incorporate his risk aversion into the LP by adding the constraint:

$$70 * BF1 + 20 * BS1 + KC \leq 975000.$$

When this is done, the solution is:

Optimal solution found at step:		11
Objective value:		820061.1
Variable	Value	Reduced Cost
BF1	3780.556	0.0000000
BS1	2916.667	0.0000000
KW	264680.6	0.0000000
KC	652027.8	0.0000000
BFW	0.0000000	3.200000
XFW	863.8889	0.0000000
PW	0.0000000	4.611115
SW	2916.667	0.0000000
BSW	0.0000000	3.533334
XSW	0.0000000	8.466666
BFC	1027.778	0.0000000
XFC	0.0000000	5.333333
PC	1891.667	0.0000000
SC	2916.667	0.0000000
BSC	0.0000000	8.466667
XSC	0.0000000	2.866666

The expected cost has increased by about $820,061 - 819,888 = 173$ dollars. A politician might consider this a price worth paying to reduce his worst case (cold winter) cost almost \$2,600. Notice, however, performance in the event of a warm winter does not look as good. The value of XFW indicates there will be almost 864 units of fuel to be disposed of at the end of a warm winter.

12.7.1 Downside Risk

There is a variety of ways of measuring risk. Variance is probably the most common measure of risk. The variance measure gives equal weight to deviations above the mean as well as below. For a symmetric distribution, this is fine, but for nonsymmetrical distributions, this is not attractive. Most people worry a lot more about returns that are below average than ones above average.

Downside risk is a reasonably intuitive way of quantifying risk that looks only at returns lower than some threshold. In words, downside risk is the expected amount by which return falls short of a specified target. To explain it more carefully, define:

$$\begin{aligned}
 P_s &= \text{probability that scenario } s \text{ occurs} \\
 T &= \text{a target return threshold that we specify} \\
 R_s &= \text{the return achieved if scenario } s \text{ occurs} \\
 D_s &= \text{the down side if scenario } s \text{ occurs} \\
 &= \max \{0, T - R_s\} \\
 ER &= \text{expected downside risk} \\
 &= p_1 D_1 + p_2 D_2 + \dots
 \end{aligned}$$

12.7.2 Example

Suppose the farmer of our earlier acquaintance has made two changes in his assessment of things: (a) he assesses the probability of a wet season as 0.7 and (b) he has eliminated beans as a possible crop, so he has only two choices (corn and sorghum). A reformulation of his model is:

```

MAX = 0.7 * RW + 0.3 * RD;
RW - 100 * C - 70 * S = 0;
RD + 10 * C - 40 * S = 0;
C + S = 1;
@FREE(RW);
@FREE(RD);

```

The variables RW and RD are the return (i.e., profit) if the season is wet or dry, respectively. Notice both RW and RD were declared as FREE, because RD in particular could be negative.

When solved, the recommendation is to plant 100% corn with a resulting expected profit of 67:

```

Optimal solution found at step:          0
Objective value:                       67.00000
Variable      Value      Reduced Cost
RW            100.0000    0.0000000
RD            -10.0000    0.0000000
C              1.000000    0.0000000
S              0.000000    6.0000000
Row   Slack or Surplus   Dual Price
  1         67.00000      1.0000000
  2         0.0000000      0.7000000
  3         0.0000000      0.3000000
  4         0.0000000      67.0000000

```

The solution makes it explicit that, if the season is dry, our profits (RD) will be negative. Let us compute the expected downside risk for a solution to this problem. We must choose a target threshold. A plausible value for this target is one such that the most conservative decision available to us just barely has an expected downside risk of zero. For our farmer, the most conservative decision is sorghum. A target value of 40 would give sorghum a downside risk of zero. To compute the expected downside risk for our problem, we want to add the following constraints:

```

DW ≥ 40 - RW
DD ≥ 40 - RD
ER = .7 DW + .3 DD

```

The constraint $DW \geq 40 - RW$ effectively sets $DW = \max(0, 40 - RW)$.

When converted to standard form and appended to our model, we get:

```

MAX = 0.7 * RW + 0.3 * RD;
RW - 100 * C - 70 * S = 0;
RD + 10 * C - 40 * S = 0;
C + S = 1;
RW + DW > 40;
RD + DD > 40;
- 0.7 * DW - 0.3 * DD + ER = 0;
@FREE(ER);
@FREE(RW);
@FREE(RD);

```

The solution is:

```

Optimal solution found at step:          2
Objective value:                        67.00000
Variable      Value      Reduced Cost
RW           100.0000    0.0000000
RD           -10.00000    0.0000000
C             1.000000    0.0000000
S             0.0000000    6.0000000
DW            0.0000000    0.0000000
DD            50.00000    0.0000000
ER            15.00000    0.0000000

Row  Slack or Surplus  Dual Price
 1      67.00000        1.0000000
 2      0.0000000        0.7000000
 3      0.0000000        0.3000000
 4      0.0000000         67.00000
 5      60.00000        0.0000000
 6      0.0000000        0.0000000
 7      0.0000000        0.0000000

```

Because we put no constraint on expected downside risk, we get the same solution as before, but with the additional information that the expected downside risk is 15.

What happens as we become more risk averse? Suppose we add the constraint $ER \leq 10$. We then get the solution:

```

Optimal solution found at step:          2
Objective value:                        65.00000
Variable      Value      Reduced Cost
RW           90.00000    0.0000000
RD             6.666667    0.0000000
C             0.6666667    0.0000000
S             0.3333333    0.0000000
DW            0.0000000    0.2800000
DD            33.33333    0.0000000
ER            10.00000    0.0000000

```

Notice the recommendation is now to put 1/3 of the land into sorghum. The profit drops modestly to 65 from 67. If the season is dry, the profit is now 6.67 rather than -10 as before. Finally, let's constrain the expected downside risk to zero with $ER \leq 0$. Then the solution is:

```

Optimal solution found at step:          2
Objective value:                        61.00000
Variable      Value      Reduced Cost
RW            70.00000    0.0000000
RD            40.00000    0.0000000
C              0.0000000    0.0000000
S              1.0000000    0.0000000
DW            0.0000000    0.2800000
DD            0.0000000    0.0000000
ER            0.0000000    0.0000000
Row   Slack or Surplus   Dual Price
 1         61.00000         1.0000000
 2         0.0000000         0.7000000
 3         0.0000000         0.4200000
 4         0.0000000         65.80000
 5         30.00000         0.0000000
 6         0.0000000        -0.1200000
 7         0.0000000        -0.4000000
 8         0.0000000         0.4000000

```

Now, all the land is planted with sorghum and expected profit drops to 61.

12.8 Choosing Scenarios

Even when outcomes are naturally discrete, the number of scenarios may be huge from a computational point of view. Consider an electrical utility company that has 20 major transformers scattered over its demand area. In planning its major capital expenditures for the coming year, the only significant source of randomness is whether or not each transformer fails. Thus, a configuration of transformer failures constitutes a scenario and therefore there are $2^{20} = 1,048,576$ scenarios. This is too many scenarios for current computational technology. Which scenarios should be included?

Intuitively, a particular scenario should be included in our analysis if the expected cost of not including it is high. The expected cost is directly related to two things: (a) the probability the scenario occurs, and (b) the difference in cost between an optimal stage 1 decision and a nonoptimal one if this scenario occurs in reality. Infanger (1994) presents a sophisticated methodology based on importance sampling for doing the above kind of sampling of scenarios “on-the-fly”. A simplified analysis is as follows.

For our transformer example, suppose transformers fail independently, each with probability 0.01. We can start to list the possible scenarios:

Failure Scenario	Probability	Cumulative
No failures	.818	.818
Transformer 1 fails	.00826	.826
Transformer 2 fails	.00826	.834
.	.	.
.	.	.
.	.	.
Transformer 20 fails	.00826	.983
Transformers 1 & 2 fail	.0000826	.9830826
Transformers 1 & 3 fail	.0000826	.9831652
.	.	.
.	.	.
.	.	.
Transformers 1 through 20 fail	10^{-40}	1.0000

Thus, the first 21 scenarios, consisting of no transformer failures and exactly one failure, account for over 98% of the probability.

To push the analysis a little more, suppose the cost of behaving non-optimally in the face of a transformer failure is at most \$10,000, and this cost is additive among transformers. Thus, an upper bound on the expected cost of not including one of the scenarios with exactly one failure is $0.00826 \times 10,000 = \82.6 . An upper bound on the expected cost of not including one of the scenarios with exactly two failures is $0.0000826 \times (10,000 + 10,000) = \1.65 .

A very conservative estimate of the expected cost of disregarding all scenarios with more than one failure is $(1 - 0.983) \times 20 \times 10,000 = \3400 .

If we use these 21 scenarios, what probabilities should be used? One choice would be to assign probability 0.818 to the non-failure scenario and $(1 - 0.818)/20 = 0.0091$ to each of the one-failure scenarios. The expected number of failures in the real system is $0.01 \times 20 = 0.2$. If we wished to match this statistic, then we would assign a probability of 0.01 to each of the one-failure scenarios and a probability of 0.8 to the no-failure scenario.

12.8.1 Matching Scenario Statistics to Targets

Suppose scenarios represent things like demand, or the return on investment, or the failure of equipment. Then, we might be interested in knowing whether (using our scenarios and associated probabilities) the scenario-based expected demand equals the forecast demand, the scenario-based expected return on a particular stock matches the forecast return for that stock, or the scenario-based expected number of machine failures matches the forecast number of machine failures.

If scenarios have already been selected, then we may wish to choose scenario probabilities to match given forecasts. Alternatively, if scenarios have not yet been selected, we may wish to choose both scenarios and probabilities to match forecasts.

12.8.2 Generating Scenarios with a Specified Covariance Structure

Carino et al. (1994), in the description of the application of stochastic programming at the Yasuda-Kasai Company, mention scenarios were chosen so as to match forecasted means and variances for forecasted quantities such as interest rates. This “matching” can also be done for covariances.

Suppose we wish to generate m observations or scenarios, on n variables (e.g., returns on investment instruments), such that the *sample* covariance matrix exactly equals a specified covariance matrix V , and the sample means exactly equal a specified vector M . We somewhat arbitrarily decide each scenario will be equally likely.

We can use a variation of a method described in Bratley, Fox, and Schrage (1987). Do a Cholesky factorization of V to give an upper triangular matrix C , so $C'C = V$. Effectively, C is the square root of V . Note, C' is the transpose of C .

Next, generate m observations on n (pseudo) random variables, so the *sample* means are all zero and the *sample* covariance matrix is the identity matrix. Note $m \geq n + 1$ may be required; $m = n + 1$ is always sufficient, so we will assume $m = n + 1$. For example, if $m = 4$ and $n = 3$, then a suitable matrix of pseudo random values is:

$$\begin{pmatrix} -1 & 1 & -1 \\ 1 & 1 & 1 \\ -1 & -1 & 1 \\ 1 & -1 & -1 \end{pmatrix}$$

Call this matrix Z .

Next, generate the desired random observations by the transformation:

$$X = M + ZC$$

where:

M = vector of desired means,

X = desired set of observations or scenarios.

Note:

$$\begin{aligned} (X - M)'(X - M) &= (ZC)'(ZC) \\ &= C'Z'ZC \end{aligned}$$

By construction, $Z'Z$ is a diagonal matrix with m 's on the diagonal. Thus, the sample covariance matrix is:

$$(X - M)'(X - M)/m = m C'C/m = C'C = V.$$

12.8.3 Generating a Suitable Z Matrix

We provided an example Z matrix for which it was obvious that it satisfied the required features:

- 1) $\sum_{i=1}^m z_{ij} = 0$ for $j = 1, 2, \dots, n$,
- 2) $\sum_{i=1}^m z_i^2 = m$ for $j = 1, 2, \dots, n$,
- 3) $\sum_{i=1}^m z_{ij} \times z_{ik} = 0$ for all j, k with $j \neq k$.

We can subsume condition (1) into condition (3) if we temporarily place a column of 1's in front of Z (i.e., as its first column). Thus, the condition:

$$\sum_{i=1}^m z_{ij} \times z_{i1} = 0$$

will imply condition (1).

With this convenient device, we can also write conditions (2) and (3) in matrix notation as simply:

- 4) $Z'Z = mI$, where I is the identity matrix with 1's down the diagonal.

There is a procedure called Gram-Schmidt orthogonalization that can be used for finding a matrix Z that satisfies conditions (2) and (3), or equivalently satisfies condition (4) in matrix notation. The Gram-Schmidt procedure will take as input an $m \times m$ matrix U of linearly independent columns and output an $m \times m$ matrix V that satisfies condition (3). It is a simple matter to scale each column of V , so condition (2) is also satisfied.

The steps of the Gram-Schmidt procedure are:

For $j = 1, 2, 3, \dots, m$:

For $t = 1, 2, \dots, j-1$:

$$a_{tj} = \left(\sum_{i=1}^m v_{it} u_{ij} \right) / \sum_{i=1}^m v_{it} v_{it}$$

For $i = 1, 2, \dots, m$:

$$v_{ij} = u_{ij} - \sum_{t=1}^{j-1} a_{tj} v_{it}$$

The v_{ij} 's now satisfy, for $j \neq t$:

$$\sum_{i=1}^m v_{ij} v_{it} = 0$$

We finally obtain the matrix Z satisfying condition (2) by discarding the first column of the $\{v_{ij}\}$ and scaling each column as follows:

For $j = 1, 2, \dots, m - 1$:

$$s_j = \sqrt{\left(\sum_{i=1}^m v_{ij+1}^2 \right)} / m$$

For $i = 1, 2, \dots, m$:

$$z_{ij} = v_{ij+1} / s_j$$

12.8.4 Example

For the case $m = 4$, a suitable U matrix is:

$$\begin{array}{cccc} 1 & 1 & 0 & 0 \\ 1 & 0 & 1 & 0 \\ 1 & 0 & 0 & 1 \\ 1 & 0 & 0 & 0 \end{array}$$

The Gram-Schmidt orthogonalization of it is:

$$\begin{array}{cccc} 1 & 0.75 & 0 & 0 \\ 1 & -0.25 & 0.66667 & 0 \\ 1 & -0.25 & -0.33333 & 0.5 \\ 1 & -0.25 & -0.33333 & -0.5 \end{array}$$

After we normalize or scale each column to satisfy condition (2) and drop the first column, we get the Z matrix:

$$\begin{array}{ccc} 1.73205 & 0 & 0 \\ -0.57735 & 1.63299 & 0 \\ -0.57735 & -0.81650 & 1.41421 \\ -0.57735 & -0.81650 & -1.41421 \end{array}$$

The U matrix we chose to illustrate the procedure was somewhat arbitrary. The only requirements are that the initial column be a vector of 1's and the columns be independent. For example, if we feel the random variables being simulated are Normal-distributed, then we could have chosen the remaining columns of U by making independent draws from a Normal distribution. The values in each column, 2, 3, ..., m of the matrix V would then also be independent, identically Normal-distributed. The values in each column of Z would be approximately Normal-distributed as m increases.

Now, suppose we wish to match the following covariance matrix:

$$V = \begin{array}{ccc} 0.01080753 & 0.01240721 & 0.01307512 \\ 0.01240721 & 0.05839169 & 0.05542639 \\ 0.01307512 & 0.05542639 & 0.09422681 \end{array}$$

and the vector of means:

$$M = \begin{array}{ccc} 1.089083 & 1.213667 & 1.234583 \end{array}$$

The Cholesky factorization of V :

$$C = \begin{array}{ccc} 0.10395930 & 0.11934681 & 0.1257716 \\ & 0.21011433 & 0.19235219 \\ & & 0.20349188 \end{array}$$

Using the Z generated above, a set of scenarios that exactly match V and M is:

$$X = \begin{array}{ccc} 1.269245 & 1.420381 & 1.452425 \\ 1.029062 & 1.487877 & 1.476078 \\ 1.029062 & 0.973204 & 1.292694 \\ 1.029062 & 0.973204 & 0.717132 \end{array}$$

12.8.5 Converting Multi-Stage Problems to Two-Stage Problems

In many systems, the effect of randomness (e.g., demand) does not carry over from one period to the next. Eppen, Martin, and Schrage (1989), for example, assumed this in their analysis of long-range capacity planning for an automobile manufacturer. Effectively, the entire plan for the next five years was decided upon in the first year. If demands are independent from year to year and there is no carryover inventory, then, when deciding what to do in period $t + 1$, one need not know what random demands occurred in periods 1 through t .

12.9 Decisions Under Uncertainty with More than Two Periods

The ideas discussed for the two-period problem can be extended to an arbitrary number of periods. The sequence of events in the general case is:

1. We make a decision.
2. Nature makes a random decision.
3. We make a decision.
4. Nature makes a random decision.
5. Etc.

The extension can be made by working backwards through time. For example, if we wished to analyze a three-period problem, we would start with the last two periods and formulate the associated two-period stochastic LP model. When the first period is taken into account, the model just developed for the last two periods is treated as the second period of a two-period problem for which now the true first period is really the first period. This process cannot continue for too many periods, because the problem size gets too large rapidly. If the number of periods is n and the number of possible states of nature each period is s , then the problem size is proportional to s^n . Thus, except for special circumstances, it is unusual to have manageable stochastic models with more than two or three periods.

12.9.1 Dynamic Programming and Financial Option Models

The term *dynamic programming* is frequently applied to the solution method described above. We illustrate it with three examples in the area of financial options. One in the stock market, one in the bond market, and the third in foreign exchange. A stock option is a right to buy a specified stock at a specified price (the so-called strike price) either on a specified date (a so-called European option) or over a specified interval of time (a so-called American option). An interesting problem in finance is the determination of the proper price for such an option. This problem was “solved” by Black and Scholes (1973). Below is a LINGO implementation of the “binomial pricing” version of the Black/Scholes model:

```

MODEL:
SETS:
    ! (OPTONB);
    ! Binomial option pricing model: We assume that
    a stock can either go up in value from one period
    to the next with probability PUP, or down with
    probability (1 - PUP). Under this assumption,
    a stock's return will be binomially distributed.
    We can then build a
    dynamic programming recursion to
    determine the option's value;
    ! No. of periods, e.g., weeks;
    PERIOD /1..20/;;
ENDSETS
DATA:
    ! Current price of the stock;
    PNOW = 40.75;
    ! Exercise price at option expiration;
    STRIKE = 40;
    ! Yearly interest rate;
    IRATE = .163;
    ! Weekly variance in log of price;
    WVAR = .005216191 ;
ENDDATA
SETS:
    !Generate our state matrix for the DP.STATE(S,T) may
    be entered from STATE(S,T-1)if the stock lost value,
    or it may be entered from STATE(S-1,T-1) if stock
    gained;
    STATE( PERIOD, PERIOD) | &1 #LE# &2:
        PRICE, ! There is a stock price, and ;
        VAL; ! a value of the option;
ENDSETS
    ! Compute number of periods;
    LASTP = @SIZE( PERIOD);
    ! Get the weekly interest rate;
    ( 1 + WRATE) ^ 52 = ( 1 + IRATE);
    ! The weekly discount factor;
    DISF = 1/( 1 + WRATE);
    ! Use the fact that if LOG( P) is normal with
    mean LOGM and variance WVAR, then P has
    mean EXP( LOGM + WVAR/2), solving for LOGM...;
    LOGM = @LOG( 1 + WRATE) - WVAR/ 2;

```

```

! Get the log of the up factor;
  LUPF = ( LOGM * LOGM + WVAR) ^ .5;
! The actual up move factor;
  UPF = @EXP( LUPF);
! and the down move factor;
  DNF = 1/ UPF;
! Probability of an up move;
  PUP = .5 * ( 1 + LOGM/ LUPF);
! Initialize the price table;
  PRICE( 1, 1) = PNOW;
! First the states where it goes down every period;
  @FOR( PERIOD( T) | T #GT# 1:
    PRICE( 1, T) = PRICE( 1, T - 1) * DNF);
! Now compute for all other states S, period T;
  @FOR( STATE( S, T) | T #GT# 1 #AND# S #GT# 1:
    PRICE( S, T) = PRICE( S - 1, T - 1) * UPF);
! Set values in the final period;
  @FOR( PERIOD( S):
    VAL( S, LASTP) = @SMAX( PRICE( S, LASTP) - STRIKE, 0)
    );
! Do the dynamic programming;
  @FOR( STATE( S, T) | T #LT# LASTP:
    VAL( S, T) = @SMAX( PRICE( S, T) - STRIKE,
      DISF * ( PUP * VAL( S + 1, T + 1) +
        ( 1 - PUP) * VAL( S, T + 1)));
! Finally, the value of the option now;
  VALUE = VAL( 1, 1);
END

```

The @SMAX function in the dynamic programming section corresponds to the decision in period T to either exercise the option and make an immediate profit of $PRICE(S, T) - STRIKE$, or wait (at least) until next period. If we wait until next period, the price can go up with probability PUP or down with probability $1 - PUP$. In either case, to convert next period's value to this period's value, we must multiply by the discount factor, $DISF$. The interesting part of the solution to this model gives:

Variable	Value
VALUE	6.549348

The actual price of this option in the Wall Street Journal when there were 19 weeks until expiration was \$6.625. So, it looks like this option is not a good buy if we are confident in our input data.

12.9.2 Binomial Tree Models of Interest Rates

Financial options based on interest rates are becoming widely available, just as options on stock prices have become widely available. In order to evaluate an interest rate option properly, we need a model of the random behavior of interest rates.

Interest rates behave differently than stock prices. Most notably, interest rates tend to hover in a finite interval (e.g., 2% to 20% per year); whereas, stock prices continue to increase year after year. Not surprisingly, a different model must be used to model interest rates. One of the simpler, yet realistic, methods for evaluating interest rate based options was developed by Black, Derman, and Toy (1990). Heath, Jarrow, and Morton (1992) present another popular model of interest rate movements.

The Black/Derman/Toy (BDT) model tries to fit two sets of data: a) the yield curve for bonds, and b) the volatility in the yield to maturity (*YTM*) for bonds. For a T period problem, the random variable of interest is the forward interest rate in each period $1, 2, \dots, T$. For period 1, the forward rate is known. For periods $t = 2, 3, \dots, T$, the BDT model chooses t forward rates, so these rates are consistent with: a) the *YTM* curve, and b) the observed volatility in *YTM*. The BDT model assumes the probability of an increase in the interest rate in a period = probability of a decrease = .5. The possible rates in a period for the BDT model are determined by two numbers: a) a base rate, which can be thought of as chosen to match the mean *YTM*, and b) a rate ratio chosen to match the volatility in the *YTM*. Specifically, the BDT model assumes $r_{i+1,t}/r_{i,t} = r_{i,t}/r_{i-1,t}$ for the i th forward rate in period t . Thus, if $r_{1,t}$ and $r_{2,t}$ are specified in period t , then all the other rates for period t are determined.

Below is a LINGO implementation of the BDT model:

```

MODEL:
SETS:
! Black/Derman/Toy binomial interest rate model(BDTCALB);
! Calibrate it to a given yield curve and volatilities;
PORM/1..5/: ! (INPUTS:)For each maturity;
    YTM, ! Yield To Maturity of Zero Coupon Bond;
    VOL; ! Volatility of Yield To Maturity of ZCB;
STATE( PORM, PORM)| &1 #GE# &2:
    FSRATE; ! (OUTPUT:)Future short rate in period j, state k;
ENDSETS
DATA:
YTM = .08, .0812, .0816, .0818, .0814;
VOL = 0, .1651, .1658, .1688, .1686;
! Write the forward rates to a file;
@TEXT( 'forwdr.dat') = FSRATE;
ENDDATA
!-----;
SETS:
TWO/1..2/;;
VYTM( PORM, TWO): YTM2; ! Period 2 YTM's;
MXS( PORM, PORM, PORM)|&1#GE# &2 #AND# &2 #GE# &3:
    PRICE; ! Price of a ZCB of maturity i, in period j, state k;
ENDSETS
! Short rate ratios must be constant
(Note: C/B=B/A <=> C=BB/A);
@FOR( STATE( J, K)| K #GT# 2:
    FSRATE( J, K) =
FSRATE( J, K -1) * FSRATE( J, K-1)/ FSRATE( J, K-2);
    @FREE( FSRATE( J, K));
);
! Compute prices for each maturity in each period and state;
@FOR( MXS( I, J, K)| J #EQ# I:
    @FREE( PRICE( I, I, K));
    PRICE( I, I, K) = 1/( 1 + FSRATE( I, K)); );
@FOR( MXS( I, J, K) | J #LT# I:
    @FREE( PRICE( I, J, K));
    PRICE( I, J, K) = .5 * ( PRICE(I, J + 1, K) + PRICE(I, J + 1, K +
1))/( 1 + FSRATE( J, K));
);

```

```

!For each maturity, price in period 1 must be consistent with its
YTM;
@FOR( PORM( I):
  PRICE( I, 1, 1)*( 1 + YTM( I))^I = 1;
);
! Compute period 2 YTM's for each maturity;
@FOR( VYTM( I, K)| I #GT# 1:
  YTM2( I, K) = (1/ PRICE( I, 2, K)^(1/( I-1))) - 1;
);
! Match the volatilities for each maturity;
@FOR( PORM( I)| I #GT# 1:
  .5 * @LOG( YTM2( I, 2)/ YTM2( I, 1)) = VOL( I);
);
END

```

When solved, we get the following forward interest rates:

Variable	Value
FSRATE(1, 1)	0.8000000E-01
FSRATE(2, 1)	0.6906015E-01
FSRATE(2, 2)	0.9607968E-01
FSRATE(3, 1)	0.5777419E-01
FSRATE(3, 2)	0.8065491E-01
FSRATE(3, 3)	0.1125973
FSRATE(4, 1)	0.4706528E-01
FSRATE(4, 2)	0.6690677E-01
FSRATE(4, 3)	0.9511292E-01
FSRATE(4, 4)	0.1352100
FSRATE(5, 1)	0.3900926E-01
FSRATE(5, 2)	0.5481167E-01
FSRATE(5, 3)	0.7701470E-01
FSRATE(5, 4)	0.1082116
FSRATE(5, 5)	0.1520465

We can display these forward rates in a more intuitive tree form:

		Period				
1	2	3	4	5		
					0.1520482	
			0.1352100	0.1082116		
		0.1125973	0.0951129	0.0770147		
	0.0960797	0.0806549	0.0669068	0.0548117		
0.0800000	0.0690602	0.0577742	0.0470653	0.0390093		

Thus, the BDT model implies that, at the start of period 1, the interest rate is .08. At the start of period 2 (end of period 1), the interest rate will be with equal probability, either .0690602 or .0960797, etc.

Now, let us suppose we want to compute the value of an interest rate cap of 10% in period 5. That is, we would like to buy insurance against the interest rate being greater than .10 in period 5. We see there are two possible interest rates, .1520482 and .1082116, that would cause the insurance to “kick in”. Assuming interest is paid at the end of each period, it should be clear such a cap is worth either 0, .0082116, or .0520482 at the end of period 5. We can calculate the expected value in earlier periods with the following dynamic programming value tree:

Period				
1	2	3	4	5
				.0520482
			.026294	.008212
		.013273	.003705	0
	.006747	.001692	0	0
.003440	.000783	0	0	0

These values apply to the end of each year. At the beginning of the first year, we would be willing to pay $.003440 / 1.08 = .003189$ per dollar of principal for this cap on interest rate at the end of year five. The following LINGO model will read in the *FSRATE* data computed by the previous model and compute the above table of values. Note the *FSRATE*'s need be computed only once. It can then be used to evaluate or price various *CAP*'s, or caplets as they are sometimes known:

```

MODEL:
SETS:
! Black/Derman/Toy binomial interest rate model.
Compute value of a cap.(BDTCMP);
PORM/1..5/: ;
STATE( PORM, PORM) | &1 #GE# &2:
FSRATE,
!(OUTPUT:) Future short rate in period j, state k;
VALUE; ! Value of the option in this state;
ENDSETS
DATA:
CAP = .10;
FSRATE = @TEXT( forwdr.dat);
ENDDATA
!-----;
LASTP = @SIZE( PORM);
@FOR( PORM( K):
VALUE(LASTP, K) = @SMAX(0, FSRATE(LASTP, K) - CAP);
);
@FOR( STATE( J, K) | J #LT# LASTP:
VALUE( J, K) =
.5 * (VALUE(J + 1, K + 1)/(1 + FSRATE(J + 1, K + 1))
+ VALUE( J + 1, K)/(1 + FSRATE( J + 1, K)));
);
! The value at the beginning of period 1;
VALUE0 = VALUE( 1, 1)/( 1 + FSRATE( 1, 1));
END

```

12.9.3 Binomial Tree Models of Foreign Exchange Rates

DeRosa (1992) describes a simple binomial tree model of foreign exchange rates. The following LINGO model illustrates the valuation of an option on the German Mark when there were 36 days until its expiration. This model illustrates the case of an American style option. That is, the option may be exercised any time before its expiration. It is a simple matter to simplify the model to the case of a European style option, which can be exercised only at maturity.

```

MODEL:
SETS:
    !(OPTONFX);
    ! Binomial option pricing model on foreign exchange:
    ! What is the value in $ of an option to buy one unit
    ! Of a foreign currency at specified/strike exchange
    ! rate? The binomial model assumes the exchange rate
    ! can either go up from one period to the next by a
    ! fixed factor, or down by another fixed factor;
    ! No. of discrete periods to use, including time now
    ! ( 6 means 5 future periods);
    PERIOD /1..6/;;
ENDSETS
DATA:
    ! Current exchange rate, $ per foreign unit;
    XCURR = .5893;
    ! Strike exchange rate, i.e., right to exchange
    ! $1 for one foreign unit at this rate;
    XSTRK =.58;
    ! Yearly interest rate in $ country;
    IRD = .0581;
    ! Yearly interest rate in foreign country;
    IRF = .0881;
    ! Years to maturity for the option;
    MATRT = .098630137; !( = 36/365);
    ! Yearly variance in exchange rate;
    SIG = .13;
ENDDATA
!-----;
SETS:
    !Generate state matrix for the DP. STATE( S, T) may
    !be entered from STATE(S, T-1) if FX rate went down,
    !or from STATE( S - 1, T - 1) if FX rate went up;
    STATE( PERIOD, PERIOD)| &1 #LE# &2:
        FXRATE, ! There is an FX rate, and...;
        VAL;    ! a value of the option;
ENDSETS
    ! Compute number of periods;
    LASTP = @SIZE( PERIOD);
    ! Initialize the FXRATE table;
    FXRATE( 1, 1) = XCURR;
    ! Compute some constants;
    ! To avoid warning messages when IRDIFM < 0;
    @FREE( IRDIFM);
    IRDIFM = ( IRD - IRF) * MATRT/( LASTP - 1);
    SIGMSR = SIG * (( MATRT/( LASTP - 1))^5);
    DISF = @EXP( - IRD * MATRT/( LASTP - 1));

```

```

! The up factor;
  UPF = @EXP( IRDIFM + SIGMSR);
! The down factor;
  DNF = @EXP( IRDIFM - SIGMSR);
! Probability of an up move( assumes SIG > 0);
  PUP = (@EXP( IRDIFM)- DNF)/( UPF - DNF);
  PDN = 1 - PUP;
! First the states where it goes down every period;
  @FOR( PERIOD( T) | T #GT# 1:
    FXRATE( 1, T) = FXRATE( 1, T - 1) * DNF);
! Now compute for all other states S, period T;
  @FOR( STATE( S, T)| T #GT# 1 #AND# S #GT# 1:
    FXRATE( S, T) = FXRATE( S - 1, T - 1) * UPF);
! Do the dynamic programming;
! Set values in the final period;
  @FOR( PERIOD( S):
    VAL( S, LASTP) =
      @SMAX( FXRATE( S, LASTP) - XSTRK, 0));
! and for the earlier periods;
  @FOR( STATE( S, T) | T #LT# LASTP:
    VAL( S, T) = @SMAX( FXRATE( S, T) - XSTRK,
      DISF * ( PUP * VAL( S + 1, T + 1) +
        PDN * VAL( S, T + 1)));
! Finally, the value of the option now;
  VALUE = VAL( 1, 1);
END

```

It is of interest to look at all of the states computed by the model:

Variable	Value
XCURR	0.5893000
XSTRK	0.5800000
IRD	0.5810000E-01
IRF	0.8810000E-01
MATRT	0.9863014E-01
SIG	0.1300000
LASTP	6.000000
IRDIFM	-0.5917808E-03
SIGMSR	0.1825842E-01
DISF	0.9988546
UPF	1.017824
DNF	0.9813264
PUP	0.4954355
PDN	0.5045645
VALUE	0.1393443E-01
FXRATE(1, 1)	0.5893000
FXRATE(1, 2)	0.5782956
FXRATE(1, 3)	0.5674967
FXRATE(1, 4)	0.5568995
FXRATE(1, 5)	0.5465002
FXRATE(1, 6)	0.5362950
FXRATE(2, 2)	0.5998035
FXRATE(2, 3)	0.5886029
FXRATE(2, 4)	0.5776116

```

FXRATE ( 2, 5)      0.5668255
FXRATE ( 2, 6)      0.5562408
FXRATE ( 3, 3)      0.6104941
FXRATE ( 3, 4)      0.5990940
FXRATE ( 3, 5)      0.5879067
FXRATE ( 3, 6)      0.5769283
FXRATE ( 4, 4)      0.6213753
FXRATE ( 4, 5)      0.6097720
FXRATE ( 4, 6)      0.5983853
FXRATE ( 5, 5)      0.6324505
FXRATE ( 5, 6)      0.6206403
FXRATE ( 6, 6)      0.6437230
  VAL ( 1, 1)      0.1393443E-01
  VAL ( 1, 2)      0.6976915E-02
  VAL ( 1, 3)      0.2228125E-02
  VAL ( 1, 4)      0.0000000
  VAL ( 1, 5)      0.0000000
  VAL ( 1, 6)      0.0000000
  VAL ( 2, 2)      0.2105240E-01
  VAL ( 2, 3)      0.1182936E-01
  VAL ( 2, 4)      0.4502463E-02
  VAL ( 2, 5)      0.0000000
  VAL ( 2, 6)      0.0000000
  VAL ( 3, 3)      0.3049412E-01
  VAL ( 3, 4)      0.1931863E-01
  VAL ( 3, 5)      0.9098311E-02
  VAL ( 3, 6)      0.0000000
  VAL ( 4, 4)      0.4137534E-01
  VAL ( 4, 5)      0.2977199E-01
  VAL ( 4, 6)      0.1838533E-01
  VAL ( 5, 5)      0.5245049E-01
  VAL ( 5, 6)      0.4064034E-01
  VAL ( 6, 6)      0.6372305E-01

```

Thus, the value of this option is $VAL(1, 1) = \$0.01393443$. For example, the option to buy 100 Marks for \$58 any time during the next 36 days is worth \$1.393443. The actual option on which the above was based had a price of \$1.368 per 100 Marks. The actual option also happened to be a European style option, rather than American. An American option can be exercised at any point during its life. A European option can be exercised only at its maturity. Thus, it is not surprising the above model should attribute a higher value to the option.

12.10 Decisions Under Uncertainty with an Infinite Number of Periods

We can consider the case of an infinite number of periods if we have a system where:

- a) we can represent the state of the system as one of a finite number of possible states,
- b) we can represent our possible actions as a finite set,
- c) given that we find the system in state s and take action x in a period, nature moves the system to state j the next period with probability $p(x, j)$,
- d) a cost $c(s, x)$ is incurred when we take action x from state s .

Such a system is called a Markov decision process and is, in fact, quite general. Our goal is to find the best action to take for each state to minimize the average cost per period. Puterman (1994) provides an excellent introduction to applications of Markov Decision Processes, as well as a thorough presentation of the theory. Manne (1960) showed how to formulate the problem of determining the best action for each state as a linear program. He defined:

$w(s,x)$ = probability that in the steady state the state is s and we take action x .

This implicitly allows for randomized policies. That is, the decision maker could flip a coin to determine his decision. It turns out, however, that there is always an optimal policy that is deterministic. Allowing randomized policies is simply a convenient computational approach.

Manne's LP is then:

$$\begin{aligned} \min &= \sum_{s,x} c(s,x) w(s,x) \\ \text{subject to:} \\ &\sum_{s,x} w(s,x) = 1, \\ &\text{For each state } s: \\ &\sum_x w(s,x) = \sum_{r,x} w(r,x) p(x,s). \end{aligned}$$

Notice the probability of going to state s depends only upon the action taken, x . Some descriptions of Markov Decision Processes give an apparently more general definition of the state transition process by letting the probability of state s depend not only upon the decision x , but also the previous state r . Thus, the transition matrix would be a three dimensional array, $p(r,x,s)$. By giving a suitably general definition of "decision", however, the format where the next state depends only upon the current decision can represent any situation representable with the three dimensional notation. For many practical problems, the $p(x,s)$ notation is more natural. For example, in an inventory system, if we decide to raise the inventory level to 15, the probability that the next state is 7 is usually independent of whether we raised the inventory level to 15 from an inventory level of 5 or of 6. Similarly, in a maintenance system, if we completely overhaul the system, the probability of the next state should be independent of the state before the overhaul. Another way of thinking about a decision is that it chooses the probability distribution from which nature chooses the next state.

Wang and Zaniewski (1996) describe a system based on a Markov decision process model for scheduling maintenance on highways in Arizona and a number of other states. It has been in use since 1982. A state in this application corresponds to a particular condition of a section of roadway. Transition probabilities describe the statistical manner in which a road deteriorates. Actions correspond to possible road repairs, such as patch, resurface, or completely replace. Electrical distribution companies have similar maintenance problems. With time, tree branches near power lines get longer and equipment deteriorates. The actions available to the electrical distribution company are things like tree trimming, installing squirrel guards, replacing old equipment, etc.

12.10.1 Example: Cash Balance Management

Suppose we are managing a cash account for which each evening there is a random input or output of cash as revenue arrives and/or bills get paid. Each morning, we observe the account level. If the cash level gets too high, we want to transfer some of the cash to a longer term investment account that pays a higher interest rate. However, if the cash account gets too low, we want to transfer funds from a longer term account into the cash account, so we always have sufficient cash on hand. Because we require discrete scenarios, let us represent the cash-on-hand status as multiples of \$1000. In order to avoid negative subscripts, let us make the following correspondence between cash on hand and state:

Cash on hand:	-2000	-1000	0	1000	2000	3000	4000	5000
State:	1	2	3	4	5	6	7	8
Cost:	14	7	0	2	4	6	8	10

Given a state, we can move to any other state by transferring funds if we incur:

- 1) a fixed cost of \$3 for making any transfer, and
- 2) a variable cost of \$5 per thousand dollars transferred.

Further, suppose that over night only three transitions are possible: go down one state, stay put, or go up one state. Their probabilities are: Prob{down one state} = .4; Prob{no change} = .1; Prob{up one state} = .5.

In state 1, we assume the probability of no change is .5; whereas, in state 8, the probability of no change is .6. We can think of the sequence of events each day as:

- i. we observe the cash level in the morning,
- ii. we make any transfers deemed appropriate,
- iii. overnight the cash level either increases by \$1000, stays the same, or decreases by \$1000.

A "scalar" model is:

$$\begin{aligned}
 \text{MIN} &= 10 * W_{88} + 18 * W_{87} + 23 * W_{86} + 28 * W_{85} \\
 &+ 33 * W_{84} + 38 * W_{83} + 43 * W_{82} + 48 * W_{81} + 16 * W_{78} \\
 &+ 8 * W_{77} + 16 * W_{76} + 21 * W_{75} + 26 * W_{74} + 31 * W_{73} \\
 &+ 36 * W_{72} + 41 * W_{71} + 19 * W_{68} + 14 * W_{67} + 6 * W_{66} \\
 &+ 14 * W_{65} + 19 * W_{64} + 24 * W_{63} + 29 * W_{62} + 34 * W_{61} \\
 &+ 22 * W_{58} + 17 * W_{57} + 12 * W_{56} + 4 * W_{55} + 12 * W_{54} \\
 &+ 17 * W_{53} + 22 * W_{52} + 27 * W_{51} + 25 * W_{48} + 20 * W_{47} \\
 &+ 15 * W_{46} + 10 * W_{45} + 2 * W_{44} + 10 * W_{43} + 15 * W_{42} \\
 &+ 20 * W_{41} + 28 * W_{38} + 23 * W_{37} + 18 * W_{36} + 13 * W_{35} \\
 &+ 8 * W_{34} + 8 * W_{32} + 13 * W_{31} + 40 * W_{28} + 35 * W_{27} \\
 &+ 30 * W_{26} + 25 * W_{25} + 20 * W_{24} + 15 * W_{23} + 7 * W_{22} \\
 &+ 15 * W_{21} + 52 * W_{18} + 47 * W_{17} + 42 * W_{16} + 37 * W_{15} \\
 &+ 32 * W_{14} + 27 * W_{13} + 22 * W_{12} + 14 * W_{11}; \\
 &! \text{ Probabilities sum to 1;} \\
 &W_{88} + W_{87} + W_{86} + W_{85} + W_{84} + W_{83} + W_{82} + W_{81} \\
 &+ W_{78} + W_{77} + W_{76} + W_{75} + W_{74} + W_{73} + W_{72} + W_{71} \\
 &+ W_{68} + W_{67} + W_{66} + W_{65} + W_{64} + W_{63} + W_{62} + W_{61} \\
 &+ W_{58} + W_{57} + W_{56} + W_{55} + W_{54} + W_{53} + W_{52} + W_{51} \\
 &+ W_{48} + W_{47} + W_{46} + W_{45} + W_{44} + W_{43} + W_{42} + W_{41}
 \end{aligned}$$

```

+ W38 + W37 + W36 + W35 + W34 + W33 + W32 + W31
+ W28 + W27 + W26 + W25 + W24 + W23 + W22 + W21
+ W18 + W17 + W16 + W15 + W14 + W13 + W12 + W11 = 1;
! Prob{out of state 1}- Prob{ into state 1} = 0;
- .4 * W82 - .5 * W81 - .4 * W72 - .5 * W71 - .4 * W62
- .5 * W61 - .4 * W52 - .5 * W51 - .4 * W42 - .5 * W41
- .4 * W32 - .5 * W31 - .4 * W22 - .5 * W21 + W18 + W17
+ W16 + W15 + W14 + W13 + .6 * W12 + .5 * W11 = 0;
! Into state 2;
- .4 * W83 - .1 * W82 - .5 * W81 - .4 * W73 - .1 * W72
- .5 * W71 - .4 * W63 - .1 * W62 - .5 * W61 - .4 * W53
- .1 * W52 - .5 * W51 - .4 * W43 - .1 * W42 - .5 * W41
- .4 * W33 - .1 * W32 - .5 * W31 + W28 + W27 + W26 + W25 + W24 + .6 *
W23 + .9 * W22 + .5 * W21 - .4 * W13 - .1 * W12 - .5 * W11 = 0;
! Into state 3;
- .4 * W84 - .1 * W83 - .5 * W82 - .4 * W74 - .1 * W73
- .5 * W72 - .4 * W64 - .1 * W63 - .5 * W62 - .4 * W54
- .1 * W53 - .5 * W52 - .4 * W44 - .1 * W43 - .5 * W42 + W38 + W37 +
W36 + W35 + .6 * W34 + .9 * W33 + .5 * W32 + W31 - .4 * W24 - .1 *
W23 - .5 * W22 - .4 * W14 - .1 * W13 - .5 * W12 = 0;
! Into state 4;
- .4 * W85 - .1 * W84 - .5 * W83 - .4 * W75 - .1 * W74
- .5 * W73 - .4 * W65 - .1 * W64 - .5 * W63 - .4 * W55
- .1 * W54 - .5 * W53 + W48 + W47 + W46 + .6 * W45 + .9 * W44 + .5 *
W43 + W42 + W41 - .4 * W35 - .1 * W34 - .5 * W33 - .4 * W25 - .1 *
W24 - .5 * W23 - .4 * W15 - .1 * W14 - .5 * W13 = 0;
! Into state 5;
- .4 * W86 - .1 * W85 - .5 * W84 - .4 * W76 - .1 * W75
- .5 * W74 - .4 * W66 - .1 * W65 - .5 * W64 + W58 + W57
+ .6 * W56 + .9 * W55 + .5 * W54 + W53 + W52 + W51 - .4 * W46 - .1 *
W45 - .5 * W44 - .4 * W36 - .1 * W35 - .5 * W34 - .4 * W26 - .1 * W25
- .5 * W24 - .4 * W16 - .1 * W15 - .5 * W14 = 0;
! Into state 6;
- .4 * W87 - .1 * W86 - .5 * W85 - .4 * W77 - .1 * W76
- .5 * W75 + W68 + .6 * W67 + .9 * W66 + .5 * W65 + W64 + W63 + W62
+ W61 - .4 * W57 - .1 * W56 - .5 * W55 - .4 * W47 - .1 * W46 - .5 *
W45 - .4 * W37 - .1 * W36 - .5 * W35 - .4 * W27 - .1 * W26 - .5 * W25
- .4 * W17 - .1 * W16 - .5 * W15 = 0;
! Into state 7;
- .4 * W88 - .1 * W87 - .5 * W86 + .6 * W78 + .9 * W77 + .5 * W76 +
W75 + W74 + W73 + W72 + W71 - .4 * W68 - .1 * W67 - .5 * W66 - .4 *
W58 - .1 * W57 - .5 * W56 - .4 * W48 - .1 * W47 - .5 * W46 - .4 * W38
- .1 * W37 - .5 * W36 - .4 * W28 - .1 * W27 - .5 * W26 - .4 * W18 -
.1 * W17 - .5 * W16 = 0;
! Into state 8;
.4 * W88 + .5 * W87 + W86 + W85 + W84 + W83 + W82 + W81 - .6 * W78 -
.5 * W77 - .6 * W68 - .5 * W67 - .6 * W58 - .5 * W57 - .6 * W48 - .5
* W47 - .6 * W38 - .5 * W37 - .6 * W28 - .5 * W27 - .6 * W18 - .5 *
W17 = 0;
END

```

Note in the objective, the term $23 * W86$ can be thought of as $(10 + 3 + 5 * 2) * W86$. Similarly, the term $+ .6 * W12$ in the "into state 1" constraint, comes from the fact that the probability there is a

change out of state 1 in the morning is $W12$. At the same time, there is also a probability of changing into state 1 from state 1 the previous morning of $W12 * \text{Prob}\{\text{down transition over night}\} = W12 * .4$. The net is $W12 - .4 * W12 = .6 * W12$.

Part of the solution report is reproduced below:

Obj. value=	5.633607	
Variable	Value	Reduced Cost
W64	0.1024590	0.0000000
W55	0.2049180	0.0000000
W44	0.2663934	0.0000000
W22	0.1311475	0.0000000
W13	0.5245902E-01	0.0000000
W33	0.2426230	0.0000000

For example, variable $W64 = 0.1024590$ means that, in a fraction 0.1024590 of the periods, we will find the system in state 6 and we will (or should) take action 4. Note, there is no other positive variable involving state 6. So, this implies, if the system is in state 6, we should always take action 4. The expected cost per day of this policy is 5.633607.

Summarizing:

If the state is 1 or less, we should raise it to state 3.

If the state is 6 or more, we should drop it to state 4.

If the state is 2, 3, 4, or 5, we should stay put.

Here is a general purpose sets formulation of a Markov decision problem, with data specific to our cash balance problem:

```
SETS: ! Markov decision process model(MARKOVDP);
STATE: H;
DCSN:;
SXD( STATE, DCSN): C, W;
DXS( DCSN, STATE): P;
ENDSETS
DATA:
! Data for the cash balance problem;
! The states ....;
STATE= SN2K SN1K S000 SP1K SP2K SP3K SP4K SP5K;
! The cost of finding system in a given state;
H = 14 7 0 2 4 6 8 10;
! Possible decisions;
DCSN= DN2K DN1K D000 DP1K DP2K DP3K DP4K DP5K;
! The cost of explicitly changing to any other state;
C = 0 8 13 18 23 28 33 38
8 0 8 13 18 23 28 33
13 8 0 8 13 18 23 28
18 13 8 0 8 13 18 23
23 18 13 8 0 8 13 18
28 23 18 13 8 0 8 13
33 28 23 18 13 8 0 8
38 33 28 23 18 13 8 0;
```

```

! Prob{ nature moves system to state j| we made decision i};
  P = .5  .5  0  0  0  0  0  0
      .4  .1  .5  0  0  0  0  0
      0  .4  .1  .5  0  0  0  0
      0  0  .4  .1  .5  0  0  0
      0  0  0  .4  .1  .5  0  0
      0  0  0  0  .4  .1  .5  0
      0  0  0  0  0  .4  .1  .5
      0  0  0  0  0  0  .4  .6;
ENDDATA
!-----;
!Minimize the average cost per period;
MIN=@SUM(SXD( S, X): ( H( S) + C( S, X))* W( S, X));
!The probabilities must sum to 1;
@SUM( SXD( S, X): W( S, X)) = 1;
!Rate at which we exit state S = rate of entry to S.
Note, W( S, X) = Prob{ state is S and we make decision X};
@FOR( STATE( S):
  @SUM( DCSN( X): W( S, X))=
    @SUM( SXD( R, K): W( R, K)* P( K, S));
);

```

In the above example, the number of decision alternatives equaled the number of states, so the transition matrix was square. In general, the number of decisions might be more or less than the number of states, so the transition matrix need not be square.

The above model minimizes the average cost per period in the long run. If discounted present value, rather than average cost per period, is of concern, then see d'Epenoux (1963) for a linear programming model, similar to the above, that does discounting.

12.11 Chance-Constrained Programs

A drawback of the methods just discussed is problem size can grow very large if the number of possible states of nature is large. Chance-constrained programs do not apply to exactly the same problem and, as a result, do not become large as the number of possible states of nature gets large. The stochastic programs discussed thus far had the feature that every constraint had to be satisfied by some combination of first- and second-period decisions. Chance-constrained programs, however, allow each constraint to be violated with a certain specified probability. An advantage to this approach for tolerating uncertainty is the chance-constrained model has essentially the same size as the LP for a corresponding problem with no random elements.

We will illustrate the idea with the snow removal problem. Under the chance-constrained approach, there are no second-stage decision variables, and we would have to specify a probability allowance for each constraint. For example, we might specify that with probability at least 0.75 we must be able to provide the snow removal capacity required by the severity of the winter. For our problem, it is very easy to see that this means we must provide 5,100 truck-days of snow removal capacity. For example, if only 4,400 truck-days of capacity were provided, then the probability of sufficient capacity would only be 0.4. Let us assume one truck-day of operation costs \$116, and one truck-day of salting equals 1.14 truck-days of plowing. Then, the appropriate chance-constrained LP is the simple model:

$$\begin{array}{rcll} \text{Min} = & 70 * \text{BF1} & + & 20 * \text{BS1} & + & 116 * \text{P} & & + & 116 * \text{S}; \\ & -\text{BF1} & & & & + & \text{P} & & + & \text{S} & = & 0; \\ & & & -\text{BS1} & & & & & + & \text{S} & = & 0; \\ & & & & & \text{P} & & & + & \text{S} & \geq & 5000; \\ & & & & & \text{P} & + & 1.14 * \text{S} & \geq & 5100; \end{array}$$

12.12 Problems

1. What is the expected value of perfect information in the corn/soybean/sorghum planting problem?
2. The farmer in the corn/soybean/sorghum problem is reluctant to plant all soybeans because, if the season is wet, he will make \$20 less per acre than he would if he had planted all corn. Can you react to his risk aversion and recommend a planting *mix* where the profit per acre is never more than \$15 from the planting mix that in retrospect would have been best for the particular outcome?
3. Analyze the snow removal problem of this chapter for the situation where the cost of fuel in a cold winter is \$80 per truck-day rather than \$73, and the cost of salt in a cold winter is \$35 rather than \$32. Include in your analysis the derivation of the expected value of perfect information.
4. A farmer has 1000 acres available for planting to either corn, sorghum, or soybeans. The yields of the three crops, in bushels per acre, as a function of the two possible kinds of season are:

	Corn	Sorghum	Beans
Wet	100	43	45
Dry	45	35	33

The probability of a wet season is 0.6. The probability of a dry season is 0.4. Corn sells for \$2/bushel; whereas, sorghum and beans each sell for \$4/bushel. The total production cost for any crop is \$100/acre, regardless of type of season. The farmer can also raise livestock. One unit of livestock uses one hundred bushels of corn. The profit contribution of one unit of livestock, exclusive of its corn consumption, is \$215. Corn can be purchased at any time on the market for \$2.20/bushel. The decision of how much to raise of livestock and of each crop must be made before the type of season is known.

- a) What should the farmer do?
- b) Formulate and solve the problem by the scenario-based stochastic programming approach.

5. A firm serves essentially two markets, East and West, and is contemplating the location of one or more distribution centers (DC) to serve these markets. A complicating issue is the uncertainty in demand in each market. The firm has enumerated three representative scenarios to characterize the uncertainty. The table below gives (i) the fixed cost per year of having a DC at each of three candidate locations, and (ii) the profit per year in each market as a function of the scenario and which DC is supplying the market. Each market will be assigned to that one open DC that results in the most profit. This assignment can be done after we realize the scenario that holds. The DC location decision must be made before the scenario is known.

DC Location	Fixed Cost	Scenario One		Scenario Two		Scenario Three	
		East	West	East	West	East	West
A	51	120	21	21	40	110	11
B	49	110	28	32	92	70	70
C	52	60	39	20	109	20	88

For example, if Scenario Three holds and we locate DC's at *A* and *C*, East would get served from *A*, West from *C*, and total profits would be $110 + 88 - 51 - 52 = 95$.

- If Scenario One holds, what is the best combination of DC's to have open?
- If Scenario Two holds, what is the best combination of DC's to have open?
- If Scenario Three holds, what is the best combination of DC's to have open?
- If all three scenarios are equally likely, what is the best combination of DC's to have open?

Portfolio Optimization

13.1 Introduction

Portfolio models are concerned with investment where there are typically two criteria: expected return and risk. The investor wants the former to be high and the latter to be low. There is a variety of measures of risk. The most popular measure of risk has been variance in return. Even though there are some problems with it, we will first look at it very closely.

13.2 The Markowitz Mean/Variance Portfolio Model

The portfolio model introduced by Markowitz (1959), see also Roy (1952), assumes an investor has two considerations when constructing an investment portfolio: expected return and variance in return (i.e., risk). Variance measures the variability in realized return around the expected return, giving equal weight to realizations below the expected and above the expected return. The Markowitz model might be mildly criticized in this regard because the typical investor is probably concerned only with variability below the expected return, so-called downside risk. The Markowitz model requires two major kinds of information: (1) the estimated expected return for each candidate investment and (2) the covariance matrix of returns. The covariance matrix characterizes not only the individual variability of the return on each investment, but also how each investment's return tends to move with other investments. We assume the reader is familiar with the concepts of variance and covariance as described in most intermediate statistics texts. Part of the appeal of the Markowitz model is it can be solved by efficient quadratic programming methods. Quadratic programming is the name applied to the class of models in which the objective function is a quadratic function and the constraints are linear. Thus, the objective function is allowed to have terms that are products of two variables such as x^2 and $x \times y$.

Quadratic programming is computationally appealing because the algorithms for linear programs can be applied to quadratic programming with only modest modifications. Loosely speaking, the reason only modest modification is required is the first derivative of a quadratic function is a linear function. Because LINGO has a general nonlinear solver, the limitation to quadratic functions is helpful, but not crucial.

13.2.1 Example

We will use some publicly available data from Markowitz (1959). Eppen, Gould and Schmidt (1991) use the same data. The following table shows the increase in price, including dividends, for three stocks over a twelve-year period:

Year	Growth in			
	S&P500	ATT	GMC	USX
43	1.259	1.300	1.225	1.149
44	1.198	1.103	1.290	1.260
45	1.364	1.216	1.216	1.419
46	0.919	0.954	0.728	0.922
47	1.057	0.929	1.144	1.169
48	1.055	1.056	1.107	0.965
49	1.188	1.038	1.321	1.133
50	1.317	1.089	1.305	1.732
51	1.240	1.090	1.195	1.021
52	1.184	1.083	1.390	1.131
53	0.990	1.035	0.928	1.006
54	1.526	1.176	1.715	1.908

For reference later, we have also included the change each year in the Standard and Poor's/S&P 500 stock index. To illustrate, in the first year, *ATT* appreciated in value by 30%. In the second year, *GMC* appreciated in value by 29%. Based on the twelve years of data, we can use any standard statistical package to calculate a covariance matrix for three stocks: *ATT*, *GMC*, and *USX*. The matrix is:

	ATT	GMC	USX
ATT	0.01080754	0.01240721	0.01307513
GMC	0.01240721	0.05839170	0.05542639
USX	0.01307513	0.05542639	0.09422681

From the same data, we estimate the expected return per year, including dividends, for *ATT*, *GMC*, and *USX* as 0.0890833, 0.213667, and 0.234583, respectively.

The correlation matrix makes it more obvious how two random variables move together. The correlation between two random variables equals the covariance between the two variables, divided by the product of the standard deviations of the two random variables. For our three investments, the correlation matrix is as follows:

	ATT	GMC	USX
ATT	1.0		
GMC	0.493895589	1.0	
USX	0.409727718	0.747229121	1.0

The correlation can be between -1 and $+1$ with $+1$ being a high correlation between the two. Notice *GMC* and *USX* are highly correlated. *ATT* tends to move with *GMC* and *USX*, but not nearly so much as *GMC* moves with *USX*.

Let the symbols *ATT*, *GMC*, and *USX* represent the fraction of the portfolio devoted to each of the three stocks. Suppose, we desire a 15% yearly return. The entire model can be written as:

```

MODEL:
!Minimize end-of-period variance in portfolio value;
[VAR] MIN = .01080754 * ATT * ATT +.01240721 * ATT * GMC +
.01307513 * ATT * USX +.01240721 * GMC * ATT +.05839170 * GMC *
GMC +.05542639 * GMC * USX +.01307513 * USX * ATT +.05542639 * USX
* GMC +.09422681 * USX * USX;
! Use exactly 100% of the starting budget;
[BUD] ATT + GMC + USX = 1;
! Required wealth at end of period;
[RET] 1.089083 * ATT + 1.213667 * GMC + 1.234583 * USX >= 1.15;
END

```

Note the two constraints are effectively in the same units. The first constraint is effectively a “beginning inventory” constraint, while the second constraint is an “ending inventory” constraint. We could have stated the expected return constraint just as easily as:

$$.0890833 * ATT + .213667 * GMC + .234583 * USX \geq .15$$

Although perfectly correct, this latter style does not measure end-of-period state in quite the same way as start-of-period state. Fans of consistency may prefer the former style.

The equivalent sets-based formulation of the model follows:

```

MODEL:
SETS:
ASSET: AMT, RET;
COVMAT(ASSET, ASSET): VARIANCE;
ENDSETS
DATA:
ASSET = ATT GMC USX;
!Covariance matrix and expected returns;
VARIANCE = .01080754 .01240721 .01307513
.01240721 .05839170 .05542639
.01307513 .05542639 .09422681;
RET = 1.0890833 1.213667 1.234583;
TARGET = 1.15;
ENDDATA
! Minimize the end-of-period variance in portfolio value;
[VAR] MIN = @SUM( COVMAT(I, J): AMT(I) * AMT(J) * VARIANCE(I, J));
! Use exactly 100% of the starting budget;
[BUDGET] @SUM( ASSET: AMT) = 1;
! Required wealth at end of period;
[RETURN] @SUM( ASSET: AMT * RET) >= TARGET;
END

```

When we solve the model, we get:

```

Optimal solution found at step:          4
Objective value:                        0.2241375E-01
Variable          Value          Reduced Cost
  TARGET          1.150000          0.0000000
AMT( ATT)         0.5300926          0.0000000
AMT( GMC)         0.3564106          0.0000000
AMT( USX)         0.1134968          0.0000000
RET( ATT)         1.089083          0.0000000
RET( GMC)         1.213667          0.0000000
RET( USX)         1.234583          0.0000000
Row      Slack or Surplus      Dual Price
  VAR      0.2241375E-01          1.000000
BUDGET    0.0000000              0.3621387
RETURN    0.0000000             -0.3538836

```

The solution recommends about 53% of the portfolio be put in *ATT*, about 36% in *GMC* and just over 11% in *USX*. The expected return is 15%, with a variance of 0.02241381 or, equivalently, a standard deviation of about 0.1497123.

We based the model simply on straightforward statistical data based on yearly returns. In practice, it may be more typical to use monthly rather than yearly data as a basis for calculating a covariance. Also, rather than use historical data for estimating the expected return of an asset, a decision maker might base the expected return estimate on more current, proprietary information about expected future performance of the asset. One may also wish to use considerable care in estimating the covariances and the expected returns. For example, one could use quite recent data to estimate the standard deviations. A large set of data extending further back in time could be used to estimate the correlation matrix. Then, using the relationship between the correlation matrix and the covariance matrix, one could derive a covariance matrix.

13.3 Dualing Objectives: Efficient Frontier and Parametric Analysis

There is no precise way for an investor to determine the “correct” tradeoff between risk and return. Thus, one is frequently interested in looking at the tradeoff between the two. If an investor wants a higher expected return, she generally has to “pay for it” with higher risk. In finance terminology, we would like to trace out the efficient frontier of return and risk. If we solve for the minimum variance portfolio over a range of values for the expected return, ranging from 0.0890833 to 0.234583, we get the following plot or tradeoff curve for our little three-asset example:

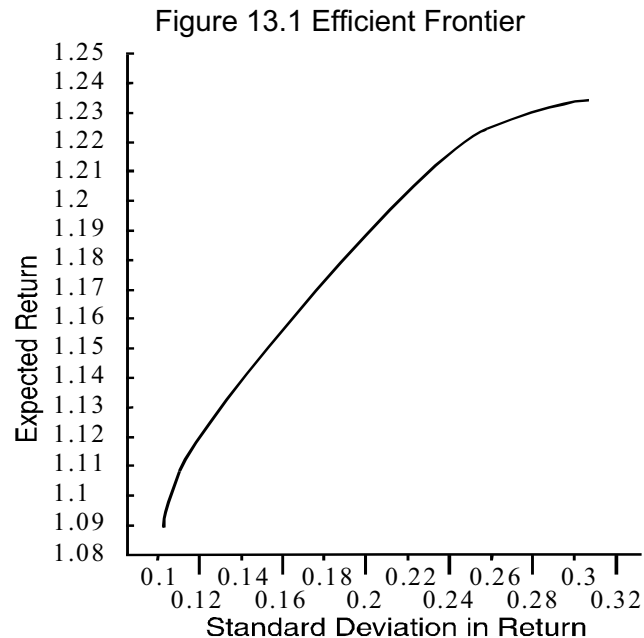

Notice the “knee” in the curve as the required expected return increases past 1.21894. This is the point where ATT drops out of the portfolio.

13.3.1 Portfolios with a Risk-Free Asset

When one of the investments available is risk free, then the optimal portfolio composition has a particularly simple form. Suppose the opportunity to invest money risk free (e.g., in government treasury bills) at 5% per year has just become available. Working with our previous example, we now have a fourth investment instrument that has zero variance and zero covariance. There is no limit on how much can be invested at 5%. We ask the question: How does the portfolio composition change as the desired rate of return changes from 15% to 5%?

We will use the following slight generalization of the original Markowitz example model. Notice a fourth instrument, treasury bills (*TBILL*), has been added:

```

MODEL:
! Add a riskless asset, TBILL;
! Minimize end-of-period variance in portfolio value;
[VAR] MIN = .01080754 * ATT * ATT +.01240721 * ATT * GMC
+.01307513 * ATT * USX +.01240721 * GMC * ATT +.05839170 * GMC *
GMC +.05542639 * GMC * USX +.01307513 * USX * ATT +.05542639 * USX
* GMC +.09422681 * USX * USX;
! Use exactly 100% of the starting budget;
[BUD] ATT + GMC + USX + TBILL = 1;
! Required wealth at end of period;
[RET] 1.089083 * ATT + 1.213667 * GMC + 1.234583 * USX + 1.05 *
TBILL >= 1.15;
END

```

Alternatively, this can be also modeled using the sets formulation:

```

MODEL:
SETS:
ASSET: AMT, RET;
COVMAT(ASSET, ASSET): VARIANCE;
ENDSETS
DATA:
ASSET= ATT, GMC, USX, TBILL;
!Covariance matrix;
VARIANCE = .01080754 .01240721 .01307513 0
.01240721 .05839170 .05542639 0
.01307513 .05542639 .09422681 0
0 0 0 0;
RET = 1.0890833 1.213667 1.234583, 1.05;
TARGET = 1.15;
ENDDATA
! Minimize the end-of-period variance in portfolio value;
[VAR] MIN= @SUM( COVMAT( I, J): AMT( I)* AMT( J) * VARIANCE( I, J));
! Use exactly 100% of the starting budget;
[BUDGET] @SUM(ASSET: AMT) = 1;
! Required wealth at end of period;
[RETURN] @SUM( ASSET: AMT * RET) >= TARGET;
END

```

When solved, we find:

```

Optimal solution found at step:      8
Objective value:                    0.2080344E-01
Variable      Value      Reduced Cost
  ATT      0.8686550E-01    -0.2093725E-07
  GMC      0.4285285          0.0000000
  USX      0.1433992    -0.2218303E-07
  TBILL     0.3412068          0.0000000
  Row      Slack or Surplus      Dual Price
  VAR      0.2080344E-01          1.0000000
  BUD      0.0000000          0.4368723
  RET      0.0000000    -0.4160689

```

Notice more than 34% of the portfolio was invested in the risk-free investment, even though its return rate, 5%, is less than the target of 15%. Further, the variance has dropped to about 0.0208 from about 0.0224.

What happens as we decrease the target return towards 5%? Clearly, at 5%, we would put zero in *ATT*, *GMC*, and *USX*. A simple form of solution would be to keep the same proportions in *ATT*, *GMC*, and *USX*, but just change the allocation between the risk-free asset and the risky ones. Let us check an intermediate point. When we decrease the required return to 10%, we get the following solution:

```

Optimal solution found at step:      8
Objective value:                    0.5200865E-02
Variable      Value      Reduced Cost
  ATT      0.4342898E-01    0.0000000
  GMC      0.2142677    0.2857124E-06
  USX      0.7169748E-01    0.1232479E-06
  TBILL     0.6706058          0.0000000
  Row      Slack or Surplus      Dual Price
  VAR      0.5200865E-02          1.0000000
  BUD      0.0000000          0.2184348
  RET      0.2384186E-07    -0.2080331

```

This solution supports our conjecture:

as we change our required return, the relative proportions devoted to risky investments do not change. Only the allocation between the risk-free asset and the risky assets change.

From the above solution, we observe that, except for round-off error, the amount invested in *ATT*, *GMC*, and *USX* is allocated in the same way for both solutions. Thus, two investors with different risk preferences would nevertheless both carry the same mix of risky stocks in their portfolio. Their portfolios would differ only in the proportion devoted to the risk-free asset. Our observation from the above example in fact holds in general. Thus, the decision of how to allocate funds among stocks, given the amount to be invested, can be separated from the questions of risk preference. Tobin received the Nobel Prize in 1981, largely for noticing the above feature, the so-called Separation Theorem. So, if you noticed it, you must be Nobel Prize caliber.

13.3.2 The Sharpe Ratio

For some portfolio p , of risky assets, excluding the risk-free asset, let:

$$\begin{aligned} R_p &= \text{its expected return,} \\ s_p &= \text{its standard deviation in return, and} \\ r_0 &= \text{the return of the risk-free asset.} \end{aligned}$$

A plausible single measure (as opposed to the two measures, risk and return) of attractiveness of portfolio p is the Sharpe ratio:

$$(R_p - r_0) / s_p$$

In words, it measures how much additional return we achieved for the additional risk we took on, relative to putting all our money in the risk-free asset.

It happens the portfolio that maximizes this ratio has a certain well-defined appeal. Suppose:

$$\begin{aligned} t &= \text{our desired target return,} \\ w_p &= \text{fraction of our wealth we place in portfolio } p \text{ (the rest placed in the risk-free asset).} \end{aligned}$$

To meet our return target, we must have:

$$(1 - w_p) * r_0 + w_p * R_p = t.$$

The standard deviation of our total investment is:

$$w_p * s_p.$$

Solving for w_p in the return constraint, we get:

$$w_p = (t - r_0) / (R_p - r_0).$$

Thus, the standard deviation of the portfolio is:

$$w_p * s_p = [(t - r_0) / (R_p - r_0)] * s_p.$$

Minimizing the portfolio standard deviation means:

$$\begin{aligned} &\text{Min } [(t - r_0) / (R_p - r_0)] * s_p \\ &\text{or} \\ &\text{Min } [(t - r_0) * s_p / (R_p - r_0)]. \end{aligned}$$

This is equivalent to:

$$\text{Max } (R_p - r_0) / s_p.$$

So, regardless of our risk/return preference, the money we invest in risky assets should be invested in the risky portfolio that maximizes the Sharpe ratio.

The following illustrates for when the risk free rate is 5%:

```

MODEL:
! Maximize the Sharpe ratio;
MAX =
(1.089083*ATT + 1.213667*GMC + 1.234583*USX - 1.05) /
((.01080754 * ATT * ATT + .01240721 * ATT * GMC
+ .01307513 * ATT * USX + .01240721 * GMC * ATT
+ .05839170 * GMC * GMC + .05542639 * GMC * USX
+ .01307513 * USX * ATT + .05542639 * USX * GMC
+ .09422681 * USX * USX)^.5);
! Use exactly 100% of the starting budget;
[BUD] ATT + GMC + USX = 1;
END

```

The solution is:

```

Optimal solution found at step:          7
Objective value:                        0.6933179
Variable          Value          Reduced Cost
ATT              0.1319260        0.1263448E-04
GMC              0.6503984        0.0000000
USX              0.2176757        0.1250699E-04

```

Notice the relative proportions of *ATT*, *GMC*, and *USX* are the same as in the previous model where we explicitly included a risk free asset with a return of 5%. For example, notice that, except for round-off error:

$$.1319262 / .6503983 = 0.08686515 / .4285286.$$

13.4 Important Variations of the Portfolio Model

There are several issues that may concern you when you think about applying the Markowitz model in its simple form:

- As we increase the number of assets to consider, the size of the covariance matrix becomes overwhelming. For example, 1000 assets implies 1,000,000 covariance terms, or at least 500,000 if symmetry is exploited.
- If the model were applied every time new data become available (e.g., weekly), we would “rebalance” the portfolio frequently, making small, possibly unimportant adjustments in the portfolio.
- There are no upper bounds on how much can be held of each asset. In practice, there might be legal or regulatory reasons for restricting the amount of any one asset to no more than, say, 5% of the total portfolio. Some portfolio managers may set the upper limit on a stock to one day’s trading volume for the stock. The reasoning being, if the manager wants to “unload” the stock quickly, the market price would be affected significantly by selling so much.

Two approaches for simplifying the covariance structure have been proposed: the scenario approach and the factor approach. For the issue of portfolio “nervousness”, the incorporation of transaction costs is useful.

13.4.1 Portfolios with Transaction Costs

The models above do not tell us much about how frequently to adjust our portfolio as new information becomes available (i.e., new estimates of expected return and new estimates of variance). If we applied the above models every time new information became available, we would be constantly adjusting our portfolio. This might make our broker happy because of all the commission fees, but that should be a secondary objective at best. The important observation is that there are costs associated with buying and selling. There are the obvious commission costs, and the not so obvious bid-ask spread. The bid-ask spread is effectively a transaction cost for buying and selling.

The method we will describe assumes transaction costs are paid at the beginning of the period. It is a straightforward exercise to modify the model to handle the case of transaction costs paid at the end of the period. The major modifications to the basic portfolio model are:

- We must introduce two additional variables for each asset, an “amount bought” variable and an “amount sold” variable.
- The budget constraint must be modified to include money spent on commissions.
- An additional constraint must be included for each asset to enforce the requirement:

$$\text{amount invested in asset } i = (\text{initial holding of } i) + (\text{amount bought of } i) - (\text{amount sold of } i).$$

13.4.2 Example

Suppose we have to pay a 1% transaction fee on the amount bought or sold of any stock and our current portfolio is 50% *ATT*, 35% *GMC*, and 15% *USX*. This is pretty close to the optimal mix. Should we incur the cost of adjusting? The following is the relevant model:

```
MODEL:
[VAR] MIN = .01080754 * ATT * ATT + .01240721 * ATT * GMC + .01307513
* ATT * USX + .01240721 * GMC * ATT + .05839170 * GMC * GMC
+ .05542639 * GMC * USX + .01307513 * USX * ATT + .05542639 * USX *
GMC + .09422681 * USX * USX;
[BUD] ATT + GMC + USX + .01 * ( BA + BG + BU + SA + SG + SU) = 1;
[RET] 1.089083 * ATT + 1.213667 * GMC + 1.234583 * USX >= 1.15;
[NETA] ATT = .50 + BA - SA;
[NETG] GMC = .35 + BG - SG;
[NETU] USX = .15 + BU - SU;
END
```

The *BUD* constraint says the total uses of funds must equal 1. Another way of interpreting the *BUD* constraint is to subtract each of the *NET* constraints from it. We then get:

$$[BUD].01 * (BA + BG + BU + SA + SG + SU) + BA + BG + BU = SA + SG + SU;$$

It says any purchases plus transaction fees must be funded by selling.

For reference, the following is the sets formulation of the above model:

```

MODEL:
SETS:
  ASSET: AMT, RETURN, BUY, SELL, START;
  COVMAT( ASSET, ASSET):VARIANCE;
ENDSETS
DATA:
  ASSET = ATT, GMC, USX;
  VARIANCE = .0108075 .0124072 .0130751
             .0124072 .0583917 .0554264
             .0130751 .0554264 .0942268;
  RETURN = 1.089083 1.213667 1.234583;
  START = .5 .35 .15;
  TARGET = 1.15;
ENDDATA
[VAR] MIN = @SUM( COVMAT(I, J): AMT(I) * AMT(J) * VARIANCE(I, J));
[BUD] @SUM( ASSET(I): AMT(I) + .01 * ( BUY(I) + SELL(I))) = 1;
[RET] @SUM( ASSET: AMT * RETURN) >= TARGET;
@FOR( ASSET(I): [NET] AMT(I) = START(I) + BUY(I) - SELL(I));
END

```

The solution follows:

```

Optimal solution found at step:          4
Objective value:                    0.2261146E-01

```

Variable	Value	Reduced Cost
ATT	0.5264748	0.0000000
GMC	0.3500000	0.0000000
USX	0.1229903	0.0000000
BA	0.2647484E-01	0.0000000
BG	0.0000000	0.4824887E-02
BU	0.0000000	0.6370753E-02
SA	0.0000000	0.6370753E-02
SG	0.0000000	0.1545865E-02
SU	0.2700968E-01	0.0000000
Row	Slack or Surplus	Dual Price
VAR	0.2261146E-01	1.0000000
BUD	0.0000000	0.3185376
RET	0.0000000	-0.3167840
NETA	0.0000000	0.3185376E-02
NETG	0.0000000	-0.1639511E-02
NETU	0.0000000	-0.3185376E-02

The solution recommends buying a little bit more *ATT*, neither buy nor sell any *GMC*, and sell a little *USX*.

13.4.3 Portfolios with Taxes

Taxes are an unpleasant complication of investment analysis that should be considered. The effect of taxes on a portfolio is illustrated by the following results during one year for two similar “growth-and-income” portfolios from the Vanguard company. Portfolio S was managed without (Sans) regard to taxes. Portfolio T was managed with after-tax performance in mind:

Portfolio	Distributions		Initial	
	Income	Gain-from-sales	Share-price	Return
S	\$0.41	\$2.31	\$19.85	33.65%
T	\$0.28	\$0.00	\$13.44	34.68%

The tax managed portfolio, probably just by chance, in fact had a higher before tax return. It looks even more attractive after taxes. If the tax rate for both dividend income and capital gains is 30%, then the tax paid at year end per dollar invested in portfolio *S* is $.3 \times (.41 + 2.31) / 19.85 = 4.1$ cents; whereas, the tax per dollar invested in portfolio *S* is $.3 \times .28 / 13.44 = 0.6$ of a cent.

Below is a generalization of the Markowitz model to take into account taxes. As input, it requires in particular:

- a) number of shares held of each kind of asset,
- b) price per share paid for each asset held, and
- c) estimated dividends per share for each kind of asset.

The results from this model will differ from a model that does not consider taxes in that this model, when considering equally attractive assets, will tend to:

- i. purchase the asset that does not pay dividends, so as to avoid the immediate tax on dividends,
- ii. sell the asset that pays dividends, and
- iii. sell the asset whose purchase cost was higher, so as to avoid more tax on capital gains.

This is all given that two assets are otherwise identical (presuming rates of return are computed including dividends). For completeness, this model also includes transaction costs and illustrates how a correlation matrix can be used instead of a covariance matrix to describe how assets move together:

```

MODEL:
! Generic Markowitz portfolio model that takes into account
bid/ask spread and taxes. (PORTAX)
Keywords: Markowitz, portfolio, taxes, transaction costs;
SETS:
ASSET: RET, START, BUY, SEL, APRICE, BUYAT, SELAT, DVPS, STD, X;
ENDSETS
DATA:
! Data based on original Markowitz example;
ASSET = TBILL  ATT      GMC      USX;
! The expected returns as growth factors;
RET = 1.05  1.089083  1.21367  1.23458;
! S. D. in return for each asset;
STD = 0      .103959  .241644  .306964;
! Starting composition of the portfolio in shares;
START = 10    50      70      350;
! Price per share at acquisition;
APRICE = 1000  80      89      21;

```

```

! Current bid/ask price per share;
  BUYAT = 1000  87      89      27;
  SELAT = 1000  86      88      26;
! Dividends per share(estimated);
  DVPS = 0      .5      0      0;
! Tax rate;
  TAXR = .32;
! The desired growth factor;
  TARGET = 1.15;
ENDDATA
SETS:
  TMAT( ASSET, ASSET) | &1 #GE# &2: CORR;
ENDSETS
DATA:
! Correlation matrix;
  CORR= 1.0
        0  1.000000
        0  0.4938961  1.000000
        0  0.4097276  0.7472293  1.000000 ;
ENDDATA
!-----;
! Min the var in portfolio return;
[OBJ] MIN =
      @SUM( ASSET( I): ( X( I)*SELAT( I)* STD( I))^2) +
      2 * @SUM( TMAT( I, J) | I #NE# J:
            CORR( I, J) * X( I)* SELAT( I) * STD( I)
            * X( J)* SELAT( J) * STD( J)) ;
! Budget constraint, sales must cover purchases + taxes;
[BUDC] @SUM( ASSET( I):
         SELAT( I) * SEL( I) - BUYAT( I) * BUY( I)) >= TAXES;
[TAXC] TAXES >= TAXR * @SUM( ASSET( I):
         DVPS( I)* X( I) + SEL( I) * ( SELAT( I) - APRICE( I)));
! After tax return requirement. This assumes we do not pay
  tax on appreciation until we sell;
[RETC] @SUM( ASSET( I):
         RET( I)* X(I)* SELAT( I)) - TAXES >=
         TARGET * @SUM( ASSET(I): START( I) * SELAT( I));
! Inventory balance for each asset;
@FOR( ASSET( I):
      [BAL] X( I) = START( I) + BUY( I) - SEL( I); );
END

```

13.4.4 Factors Model for Simplifying the Covariance Structure

Sharpe (1963) introduced a substantial simplification to the modeling of the random behavior of stock market prices. He proposed that there is a “market factor” that has a significant effect on the movement of a stock. The market factor might be the Dow-Jones Industrial average, the S&P 500 average, or the Nikkei index. If we define:

$$\begin{aligned} M &= \text{the market factor,} \\ m_0 &= E(M), \\ s_0^2 &= \text{var}(M), \\ e_i &= \text{random movement specific to stock } i, \\ s_i^2 &= \text{var}(e_i). \end{aligned}$$

Sharpe’s approximation assumes (where $E(\cdot)$ denotes expected value):

$$\begin{aligned} E(e_i) &= 0 \\ E(e_i e_j) &= 0 \quad \text{for } i \neq j, \\ E(e_i M) &= 0. \end{aligned}$$

Then, according to the Sharpe single factor model, the return of one dollar invested in stock or asset i is:

$$u_i + b_i M + e_i.$$

The parameters u_i and b_i are obtained by regression (e.g., least squares, of the return of asset i on the market factor). The parameter b_i is known as the “beta” of the asset. Let:

$$X_i = \text{amount invested in asset } i \text{ and}$$

define the variance in return of the portfolio as:

$$\begin{aligned} &\text{var}[\sum X_i(u_i + b_i M + e_i)] \\ &= \text{var}(\sum X_i b_i M) + \text{var}(\sum X_i e_i) \\ &= (\sum X_i b_i)^2 s_0^2 + \sum X_i^2 s_i^2. \end{aligned}$$

Thus, our problem can be written:

$$\begin{aligned} &\text{Minimize} \quad Z^2 s_0^2 + \sum X_i^2 s_i^2 \\ &\text{subject to} \\ &\quad Z - \sum X_i b_i = 0 \\ &\quad \sum X_i = 1 \\ &\quad \sum X_i (u_i + b_i m_0) \geq r. \end{aligned}$$

So, at the expense of adding one constraint and one variable, we have reduced a dense covariance matrix to a diagonal covariance matrix.

In practice, perhaps a half dozen factors might be used to represent the “systematic risk”. That is, the return of an asset is assumed to be correlated with a number of indices or factors. Typical factors might be a market index such as the S&P 500, interest rates, inflation, defense spending, energy prices, gross national product, correlation with the business cycle, various industry indices, etc. For example, bond prices are very affected by interest rate movements.

13.4.5 Example of the Factor Model

The Factor Model represents the variance in return of an asset as the sum of the variances due to the asset's movement with one or more factors, plus a factor-independent variance.

To illustrate the factor model, we used multiple regression to regress the returns of *ATT*, *GMC*, and *USX* on the S&P 500 index for the same period. The model with solution is:

```

MODEL:
! Multi factor portfolio model;
SETS:
  ASSET: ALPHA, SIGMA, X;
  FACTOR: RETF, SIGFAC, Z;
  AXF( ASSET, FACTOR): BETA;
ENDSETS
DATA:
! The factor(s);
  FACTOR = SP500;
! Mean and s.d. of factor(s);
  RETF = 1.191460;
  SIGFAC = .1623019;
! The stocks were multi-regressed on the factors;
! i.e.: Return(i) = Alpha(i) + Beta(i) * SP500 + error(i);
  ASSET =      ATT          GMC          USX;
  ALPHA = .563976   -.263502   -.580959;
  BETA =  .4407264   1.23980    1.52384;
  SIGMA = .075817   .125070   .173930;
! The desired return;
  TARGET = 1.15;
ENDDATA
!-----;
! Min the var in portfolio return;
[OBJ] MIN
      = @SUM( FACTOR( J):( SIGFAC( J) * Z( J))^2)
      + @SUM( ASSET( I): ( SIGMA( I) * X( I))^2) ;
! Compute portfolio betas;
@FOR( FACTOR( J):
  Z( J) = @SUM( ASSET( I): BETA( I, J) * X( I));
);
! Budget constraint;
@SUM( ASSET: X) = 1;
! Return requirement;
@SUM( ASSET( I): X( I) * ALPHA( I))
+ @SUM( FACTOR( J): Z( J) * RETF( J)) >= TARGET;
END

```

Part of the solution is:

Variable	Value	Reduced Cost
TARGET	1.150000	0.0000000
X(ATT)	0.5276550	0.0000000
X(GMC)	0.3736851	0.0000000
X(USX)	0.9865990E-01	0.0000000
Z(SP500)	0.8461882	0.0000000
Row	Slack or Surplus	Dual Price
OBJ	0.0229409	1.000000
2	0.0000000	0.3498846
3	0.0000000	0.3348567
4	0.0000000	-0.3310770

Notice the portfolio makeup is slightly different. However, the estimated variance of the portfolio is very close to our original portfolio.

13.4.6 Scenario Model for Representing Uncertainty

The scenario approach to modeling uncertainty assumes the possible future situations can be represented by a small number of “scenarios”. The smallest number used is typically three (e.g., “optimistic,” “most likely,” and “pessimistic”). Some of the original ideas underlying the scenario approach come from the approach known as stochastic programming; see Madansky (1962), for example. For a discussion of the scenario approach for large portfolios, see Markowitz and Perold (1981) and Perold (1984). For a thorough discussion of the general approach of stochastic programming, see Infanger (1992). Eppen, Martin, and Schrage (1988) use the scenario approach for capacity planning in the automobile industry.

Let:

$$\begin{aligned}
 P_s &= \text{Probability scenario } s \text{ occurs,} \\
 u_{is} &= \text{return of asset } i \text{ if the scenario is } s, \\
 X_i &= \text{investment in asset } i, \\
 Y_s &= \text{deviation of actual return from the mean if the scenario is } s; \\
 &= \sum_i X_i (u_{is} - \sum_q P_q u_{iq}).
 \end{aligned}$$

Our problem in algebraic form is:

$$\begin{aligned}
 &\text{Minimize } \sum_s P_s Y_s^2 \\
 &\text{subject to} \\
 &Y_s - \sum_i X_i (u_{is} - \sum_q P_q u_{iq}) = 0 \text{ (deviation from mean of each scenario, } s) \\
 &\sum_i X_i = 1 \text{ (budget constraint)} \\
 &\sum_i X_i \sum_s P_s u_{is} \geq r \text{ (desired return).}
 \end{aligned}$$

If asset i has an inherent variability v_i^2 , the objective generalizes to:

$$\text{Min } \sum_i X_i^2 v_i^2 + \sum_s P_s Y_s^2$$

The key feature is that, even though this formulation has a few more constraints, the covariance matrix is diagonal and, thus, very sparse.

You will generally also want to put upper limits on what fraction of the portfolio is invested in each asset. Otherwise, if there are no upper bounds or inherent variabilities specified, the optimization will tend to invest in only as many assets as there are scenarios.

13.4.7 Example: Scenario Model for Representing Uncertainty

We will use the original data from Markowitz once again. We simply treat each of the 12 years as being a separate scenario, independent of the other 11 years. Because of the amount of data involved, it is convenient to use the 'sets' form of LINGO in the following model:

```

MODEL:
! Scenario portfolio model;
SETS:
  SCENE/1..12/: PRB, R, DVU, DVL;
  ASSET/ ATT,  GMT,  USX/: X;
  SXI( SCENE, ASSET): VE;
ENDSETS
DATA:
  TARGET = 1.15;
! Data based on original Markowitz example;
  VE =
    1.300    1.225    1.149
    1.103    1.290    1.260
    1.216    1.216    1.419
    0.954    0.728    0.922
    0.929    1.144    1.169
    1.056    1.107    0.965
    1.038    1.321    1.133
    1.089    1.305    1.732
    1.090    1.195    1.021
    1.083    1.390    1.131
    1.035    0.928    1.006
    1.176    1.715    1.908;
! All scenarios considered to be equally likely;
  PRB= .08333 .08333 .08333 .08333 .08333 .08333
      .08333 .08333 .08333 .08333 .08333 .08333;
ENDDATA
! Target ending value;
[RET] AVG >= TARGET;
! Compute expected value of ending position;
  AVG = @SUM( SCENE: PRB * R);
  @FOR( SCENE( S):
! Measure deviations from average;
    DVU( S) - DVL( S) = R(S) - AVG;
! Compute value under each scenario;
    R( S) = @SUM( ASSET( J): VE( S, J) * X( J));

```

```

! Budget;
[BUD] @SUM( ASSET: X) = 1;
[VARI] VAR = @SUM( SCENE: PRB * ( DVU + DVL)^2);
[SEMIVARI] SEMIVAR = @SUM( SCENE: PRB * (DVL)^2);
[DOWNRISK] DNRISK = @SUM( SCENE: PRB * DVL);
! Set objective to VAR, SEMIVAR, or DNRISK;
[OBJ] MIN = VAR;
END

```

When solved, (part of) the solution is:

```

Optimal solution found at step:          4
Objective value:                      0.2056007E-01
Variable          Value          Reduced Cost
X( ATT)           0.5297389         0.0000000
X( GMT)           0.3566688         0.0000000
X( USX)           0.1135923         0.0000000
Row      Slack or Surplus      Dual Price
RET      0.0000000             -0.3246202
BUD      0.0000000             0.3321931
OBJ      0.2056007E-01         1.0000000

```

The solution should be familiar. The alert reader may have noticed the solution suggests the same portfolio (except for round-off error) as our original model based on the covariance matrix (based on the same 12 years of data as in the above scenario model). This, in fact, is a general result. In other words, if the covariance matrix and expected returns are calculated directly from the original data by the traditional statistical formulae, then the covariance model and the scenario model, based on the same data, will recommend exactly the same portfolio.

The careful reader will have noticed the objective function from the scenario model (0.02056) is slightly less than that of the covariance model (.02241). The exceptionally perceptive reader may have noticed $12 \times 0.02054597/11$ is, except for round-off error, equal to 0.002241. The difference in objective value is a result simply of the fact that standard statistics packages tend to divide by $N - 1$ rather than N when computing variances and covariances, where N is the number of observations. Thus, a slightly more general statement is, if the covariance matrix is computed using a divisor of N rather than $N - 1$, then the covariance model and the scenario model will give the same solution, including objective value.

13.5 Measures of Risk other than Variance

The most common measure of risk is variance (or its square root, the standard deviation). This is a reasonable measure of risk for assets that have a symmetric distribution and are traded in a so-called “efficient” market. If these two features do not hold, however, variance has some drawbacks. Consider the four possible growth distributions in Figure 13.2.

Investments *A*, *B*, and *C* are equivalent according to the variance measure because each has an expected growth of 1.10 (an expected return of 10%) and a variance of 0.04 (standard deviation around the mean of 0.20). Risk-averse investors would, however, probably not be indifferent among the three. Under distribution (*A*), you would never lose any of your original investment, and there is a 0.2 probability of the investment growing by a factor of 1.5 (i.e., a 50% return). Distribution (*C*), on the other hand, has a 0.2 probability of an investment decreasing to 0.7 of its original value (i.e., a negative 30% return). Risk-averse investors would tend to prefer (*A*) most and to prefer (*C*) least. This illustrates variance need not be a good measure of risk if the distribution of returns is not symmetric:

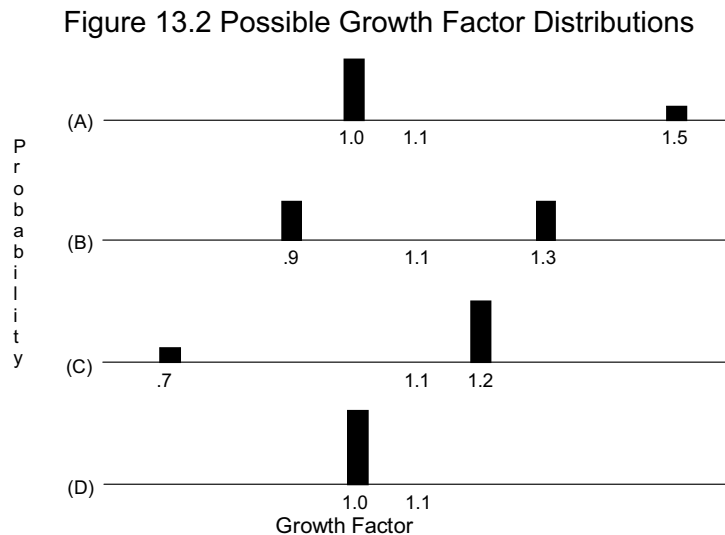

Investment (*D*) is an inefficient investment. It is dominated by (*A*). Suppose the only investments available are (*A*) and (*D*) and our goal is to have an expected return of at least 5% (i.e., a growth factor of 1.05) and the lowest possible variance. The solution is to put 50% of our investment in each of (*A*) and (*D*). The resulting variance is 0.01 (standard deviation = 0.1). If we invested 100% in (*A*), the standard deviation would be 0.20. Nevertheless, we would prefer to invest 100% in (*A*). It is true the return is more random. However, our profits are always at least as high under every outcome. (If the randomness in profits is an issue, we can always give profits to a worthy educational institution when our profits are high to reduce the variance.) Thus, the variance objective may cause us to choose inefficient investments.

In active and efficient markets such as major stock markets, you will tend not to find investments such as (*D*) because investors will realize (*A*) dominates (*D*). Thus, the market price of (*D*) will drop until its return approaches competing investments. In investment decisions regarding new physical facilities, however, there are no strong market forces making all investment candidates “efficient”, so the variance risk measure may be less appropriate in such situations.

13.5.1 Maximizing the Minimum Return

A very conservative investor might react to risk by maximizing the minimum return over scenarios. There are some curious implications from this. Suppose the only investments available are A and C above and the two scenarios are:

Scenario	Probability	Payoff from A	Payoff from C
1	0.8	1.0	1.2
2	0.2	1.5	0.7

If we wish to maximize the minimum possible wealth, the probability of a scenario does not matter, as long as the probability is positive. Thus, the following LP is appropriate:

```

MODEL:
  MAX = WMIN;
  ! Initial budget constraint;
    A + C = 1;
  ! Wealth under scenario 1;
  - WMIN + A + 1.2 * C > 0;
  ! Wealth under scenario 2;
  - WMIN + 1.5 * A + 0.7 * C > 0;
END

```

The solution is:

```

Optimal solution found at step:      1
Objective value:                    1.100000
Variable      Value      Reduced Cost
  WMIN         1.100000      0.0000000
    A         0.500000      0.0000000
    C         0.500000      0.0000000
Row   Slack or Surplus   Dual Price
  1         1.100000         1.000000
  2         0.000000         1.100000
  3         0.000000        -0.8000000
  4         0.000000        -0.2000000

```

Given that both investments have an expected return of 10%, it is not surprising the expected growth factor is 1.10. That is, a return of 10%. The possibly surprising thing is there is no risk. Regardless of which scenario occurs, the \$1 initial investment will grow to \$1.10 if 50 cents is placed in each of A and C .

Now, suppose an extremely reliable friend provides us with the interesting news that, “if scenario 1 occurs, then investment C will payoff 1.3 rather than 1.2”. This is certainly good news. The expected return for C has just gone up, and its downside risk has certainly not gotten worse. How should we react to it? We make the obvious modification in our model:

```

MODEL:
  MAX = WMIN;
  ! Initial budget constraint;
      A +      C = 1;
  ! Wealth under scenario 1;
  - WMIN +      A + 1.3 * C > 0;
  ! Wealth under scenario 2;
  - WMIN + 1.5 * A + 0.7 * C > 0;
END

```

and re-solve it to find:

```

Optimal solution found at step:      1
Objective value:                    1.136364

```

Variable	Value	Reduced Cost
WMIN	1.136364	0.0000000
A	0.5454545	0.0000000
C	0.4545455	0.0000000

Row	Slack or Surplus	Dual Price
1	1.136364	1.000000
2	0.0000000	1.136364
3	0.0000000	-0.7272727
4	0.0000000	-0.2727273

This is a bit curious. We have decreased our investment in C . This is as if our friend had continued on: “I have this very favorable news regarding stock C . Let’s sell it before the market has a chance to react”. Why the anomaly? The problem is we are basing our measure of goodness on a single point among the possible payoffs. In this case, it is the worst possible. For a further discussion of these issues, see Clyman (1995).

13.5.2 Value at Risk

In 1994, J.P. Morgan popularized the “Value at Risk” (VAR) concept with the introduction of their RiskMetrics™ system. To use VAR, you must specify two numbers: 1) an interval of time (e.g., one day) over which you are concerned about losing money, and 2) a probability threshold (e.g., 5%) beyond which you care about harmful outcomes. VAR is then defined as that amount of loss in one day that has at most a 5% probability of being exceeded. A comprehensive survey of VAR is Jorion (2001).

Example

Suppose that one day from now we think that our portfolio will have appreciated in value by \$12,000. The actual value, however, has a Normal distribution with a standard deviation of \$10,000. From a Normal table, we can determine that a left tail probability of 5% corresponds to an outcome that is 1.644853 standard deviations below the mean. Now:

$$12000 - 1.644853 * 10000 = -4448.50.$$

So, we would say that the value at risk is \$4448.50.

13.5.3 Example of VAR

Let us apply the VAR approach to our standard example, the ATT/GMC/USC model. Suppose that our risk tolerance is 5% and we want to minimize the value at risk of our portfolio. This is equivalent to maximizing that threshold, so the probability our wealth is below this threshold is at most .05.

Analysis:

A left tail probability of 5% corresponds to probability threshold. We want to consider the point that is 1.64485 standard deviations below the mean. Minimizing the value at risk corresponds to choosing the mean and standard deviation of the portfolio, so the (mean - 1.64485 * (standard deviation)) is maximized. The following model will do this:

```

MODEL: ! Markowitz Value at Risk Portfolio Model(PORTVAR);
SETS:
  STOCKS: AMT, RET;
  COVMAT(STOCKS, STOCKS): VARIANCE;
ENDSETS
DATA:
  STOCKS =      ATT      GMC      USX;
!Covariance matrix and expected returns;
  VARIANCE = .01080754 .01240721 .01307513
             .01240721 .05839170 .05542639
             .01307513 .05542639 .09422681 ;
  RET = 1.0890833  1.213667  1.234583 ;
  STARTW = 1.0; ! How much we start with;
  PROB = .05;! Risk threshold, must be < .5;
ENDDATA
!-----;
! Get the s.d. corresponding to this risk threshold;
  PROB = @PSN( Z);
  @FREE( Z);
! Maximize value not at risk;
[VAR] Max = ARET + Z * SD;
  ARET = @SUM( STOCKS: AMT * RET) ;
  SD = (@SUM( COVMAT(I, J): AMT(I) * AMT(J) * VARIANCE(I, J)))^.5;
! Use exactly 100% of the starting budget;
[BUDGET] @SUM( STOCKS: AMT) = STARTW;
END
[VAR] Max = ARET + Z * SD;
  ARET = @SUM( STOCKS: AMT * RET) ;
  SD = (@SUM( COVMAT(I, J): AMT(I) * AMT(J) * VARIANCE(I, J)))^.5;
! Use exactly 100% of the starting budget;
[BUDGET] @SUM( STOCKS: AMT) = STARTW;
END

```

With solution:

Variable	Value	Reduced Cost
PROB	0.5000000E-01	0.0000000
Z	-1.644853	0.0000000
ARET	1.109300	0.0000000
SD	0.1115853	0.0000000
AMT (ATT)	0.8430340	0.0000000
AMT (GMC)	0.1253302	0.0000000
AMT (USX)	0.3163585E-01	0.0000000
RET (ATT)	1.089083	0.0000000
RET (GMC)	1.213667	0.0000000
RET (USX)	1.234583	0.0000000
Row	Slack or Surplus	Dual Price
1	-0.4163336E-16	-1.081707
VAR	0.9257590	1.000000
3	-0.2220446E-15	1.000000
4	0.0000000	-1.644853
BUDGET	0.0000000	0.9257590

Note that, if we invested solely in ATT, the portfolio variance would be .01080754. So, the standard deviation would be .103959, and the VAR would be $1 - (1.089083 - 1.644853 * .103959) = .0818$.

The portfolio is efficient because it is maximizing a weighted combination of the expected return and (a negatively weighted) standard deviation. Thus, if there is a portfolio that has both higher expected return and lower standard deviation, then the above solution would not maximize the objective function above.

Note, if you use: $PROB = .1988$, you get essentially the original portfolio considered for the ATT/GMC/USX problem.

13.6 Scenario Model and Minimizing Downside Risk

Minimizing the variance in return is appropriate if either:

- 1) the actual return is Normal-distributed or
- 2) the portfolio owner has a quadratic utility function.

In practice, it is difficult to show either condition holds. Thus, it may be of interest to use a more intuitive measure of risk. One such measure is the downside risk, which intuitively is the expected amount by which the return is less than a specified target return. The approach can be described if we define:

T = user specified target threshold. When risk is disregarded, this is typically less than the maximum expected return and greater than the return under the worst scenario.

Y_s = amount by which the return under scenario s falls short of target.

$$= \max\{0, T - \sum X_i u_{is}\}$$

The model in algebraic form is then:

$$\begin{aligned} & \text{Min } \sum P_s Y_s && \text{! Minimize expected downside risk} \\ & \text{subject to} && \\ & \quad (\text{compute deviation below target of each scenario, } s): && \\ & \quad Y_s - T + \sum X_i u_{is} \geq 0 && \\ & \quad \sum X_i = 1 && \text{(budget constraint)} \\ & \quad \sum X_i \sum P_s u_{is} \geq r && \text{(desired return).} \end{aligned}$$

Notice this is just a linear program.

13.6.1 Semi-variance and Downside Risk

The most common alternative suggested to variance as a measure of risk is some form of downside risk. One such measure is semi-variance. It is essentially variance, except only deviations below the mean are counted as risk. The scenario model is well suited to such measures. The previous scenario model needs only a slight modification to convert it to a semi-variance model. The Y variables are redefined to measure the deviation below the mean only, zero otherwise. The resulting model is:

```

MODEL:
! Scenario portfolio model;
! Minimize the semi-variance;
SETS:
  SCENE/1..12/: PRB, R, DVU, DVL;
  ASSET/ ATT, GMT, USX/: X;
  SXI( SCENE, ASSET): VE;
ENDSETS
DATA:
  TARGET = 1.15;
! Data based on original Markowitz example;
VE =
  1.300    1.225    1.149
  1.103    1.290    1.260
  1.216    1.216    1.419
  0.954    0.728    0.922
  0.929    1.144    1.169
  1.056    1.107    0.965
  1.038    1.321    1.133
  1.089    1.305    1.732
  1.090    1.195    1.021
  1.083    1.390    1.131
  1.035    0.928    1.006
  1.176    1.715    1.908;
! All scenarios happen to be equally likely;
PRB= .0833333 .0833333 .0833333 .0833333 .0833333
     .0833333 .0833333 .0833333 .0833333 .0833333
     .0833333 .0833333;
ENDDATA
! Compute value under each scenario;
@FOR(SCENE(S):R(S) = @SUM(ASSET(J):VE(S,J) * X(J));
! Measure deviations from average;
  DVU( S) - DVL( S) = R(S) - AVG;;

```



```

! Budget;
[BUD] @SUM( ASSET: X) = 1;
! Compute expected value of ending position;
[DEFAVG] AVG = @SUM( SCENE: PRB * R);
! Target ending value;
[RET] AVG > TARGET;
! Minimize the semi-variance;
[OBJ] MIN = @SUM( SCENE: PRB * DVL^2);
END

```

The resulting solution is:

```

Optimal solution found at step:          4
Objective value:                      0.8917110E-02

```

Variable	Value	Reduced Cost
R(1)	1.238875	0.0000000
R(2)	1.170760	0.0000000
R(3)	1.294285	0.0000000
R(4)	0.9329399	0.0000000
R(5)	1.029848	0.0000000
R(6)	1.022875	0.0000000
R(7)	1.085554	0.0000000
R(8)	1.345299	0.0000000
R(9)	1.067442	0.0000000
R(10)	1.113355	0.0000000
R(11)	1.019688	0.0000000
R(12)	1.479083	0.0000000
DVU(1)	0.8887491E-01	0.0000000
DVU(2)	0.2076016E-01	0.0000000
DVU(3)	0.1442846	0.0000000
DVU(4)	0.0000000	0.3617666E-01
DVU(5)	0.0000000	0.2002525E-01
DVU(6)	0.0000000	0.2118756E-01
DVU(7)	0.0000000	0.1074092E-01
DVU(8)	0.1952993	0.0000000
DVU(9)	0.0000000	0.1375965E-01
DVU(10)	0.0000000	0.6107114E-02
DVU(11)	0.0000000	0.2171863E-01
DVU(12)	0.3290833	0.0000000
DVL(1)	0.0000000	0.8673617E-09
DVL(2)	0.0000000	0.8673617E-09
DVL(3)	0.0000000	0.8673617E-09
DVL(4)	0.2170601	0.0000000
DVL(5)	0.1201515	0.0000000
X(ATT)	0.5757791	0.0000000
X(GMT)	0.3858243E-01	0.0000000
X(USX)	0.3856385	0.0000000

Row	Slack or Surplus	Dual Price
BUD	0.0000000	0.1198420
DEFAVG	0.0000000	-0.9997334E-02
RET	0.0000000	-0.1197184
OBJ	0.8917110E-02	1.0000000

Notice the objective value is less than half that of the variance model. We would expect it to be at most half, because it considers only the down (not the up) deviations. The most noticeable change in the portfolio is substantial funds have been moved to *USX* from *GMC*. This is not surprising if you look at the original data. In the years in which *ATT* performs poorly, *USX* tends to perform better than *GMC*.

13.6.2 Downside Risk and MAD

If the threshold for determining downside risk is the mean return, then minimizing the downside risk is equivalent to minimizing the mean absolute deviation (MAD) about the mean. This follows easily because the sum of deviations (not absolute) about the mean must be zero. Thus, the sum of deviations above the mean equals the sum of deviations below the mean. Therefore, the sum of absolute deviations is always twice the sum of the deviations below the mean. Thus, minimizing the downside risk below the mean gives exactly the same recommendation as minimizing the sum of absolute deviations below the mean. Konno and Yamazaki (1991) use the MAD measure to construct portfolios from stocks on the Tokyo stock exchange.

13.6.3 Scenarios Based Directly Upon a Covariance Matrix

If only a covariance matrix is available, rather than original data, then, not surprisingly, it is nevertheless possible to construct scenarios that match the covariance matrix. The following example uses just four scenarios to represent the possible returns from the three assets: *ATT*, *GMC*, and *USX*. These scenarios have been constructed, using the methods of section 12.8.2, so they mimic behavior consistent with the original covariance matrix:

```

MODEL:
SETS:
! Each asset has a variable value and an average return;
ASSET/ATT, GMC, USX/: AMT, RET;
! the variance of return at each scenario (which can be negative),
and the probability of it happening;
SCEN/1..4/: Y, P;
! Return for each asset under each scenario;
COVMAT( SCEN, ASSET):ENTRY;
ENDSETS
DATA:
ENTRY = .9851237 1.304437 1.097669
        1.193042 1.543131 1.756196
        .9851237 .8842088 1.119948
        1.193042 1.122902 .9645076;
RET = 1.089083 1.213667 1.234583;
P = .25 .25 .25 .25;
ENDDATA
! Minimize the variance;
MIN = @SUM( SCEN: Y * Y * P);
! Compute the return under each of 4 scenarios;
@FOR( SCEN(I): Y(I) - @SUM( ASSET(J): ENTRY(I,J) * AMT(J) ) + MEAN = 0 );
! The Budget constraint;
@SUM( ASSET: AMT ) = 1;
! Define or compute the mean;
@SUM( ASSET: AMT * RET ) = MEAN;
MEAN > 1.15; ! Target return;

```

```

! The variance of each return can be negative;
@FOR(SCEN: @FREE(Y));
END

```

When solved, we get the familiar solution:

```

Optimal solution found at step:          4
Objective value:                      0.2241380E-01

```

Variable	Value	Reduced Cost
MEAN	1.150000	0.0000000
AMT(ATT)	0.5300912	0.0000000
AMT(GMC)	0.3564126	0.0000000
AMT(USX)	0.1134962	-0.9242825E-08
RET(ATT)	1.089083	0.0000000
RET(GMC)	1.213667	0.0000000
RET(USX)	1.234583	0.0000000
Y(1)	-0.3829557E-01	0.0000000
Y(2)	0.2317340	0.0000000
Y(3)	-0.1855416	0.0000000
Y(4)	-0.7894565E-02	0.0000000
P(1)	0.2500000	0.0000000
P(2)	0.2500000	0.0000000
P(3)	0.2500000	0.0000000
P(4)	0.2500000	0.0000000
ENTRY(1, ATT)	0.9851237	0.0000000
ENTRY(1, GMC)	1.304437	0.0000000
ENTRY(1, USX)	1.097669	0.0000000
ENTRY(2, ATT)	1.193042	0.0000000
ENTRY(2, GMC)	1.543131	0.0000000
ENTRY(2, USX)	1.756196	0.0000000
ENTRY(3, ATT)	0.9851237	0.0000000
ENTRY(3, GMC)	0.8842088	0.0000000
ENTRY(3, USX)	1.119948	0.0000000
ENTRY(4, ATT)	1.193042	0.0000000
ENTRY(4, GMC)	1.122902	0.0000000
ENTRY(4, USX)	0.9645076	0.0000000

Row	Slack or Surplus	Dual Price
1	0.2241380E-01	1.000000
2	0.0000000	0.1914778E-01
3	0.0000000	-0.1158670
4	0.0000000	0.9277079E-01
5	0.0000000	0.3947280E-02
6	0.0000000	0.3621391
7	0.0000000	-0.3538852
8	0.0000000	-0.3538841

Notice the objective function value and the allocation of funds over *ATT*, *GMC*, and *USX* are essentially identical to our original portfolio example.

13.7 Hedging, Matching and Program Trading

13.7.1 Portfolio Hedging

Given a “benchmark” portfolio B , we say we hedge B if we construct another portfolio C such that, taken together, B and C have essentially the same return as B , but lower risk than B . Typically, our portfolio B contains certain components that cannot be removed. Thus, we want to buy some components negatively correlated with the existing ones. Examples are:

- An airline knows it will have to purchase a lot of fuel in the next three months. It would like to be insulated from unexpected fuel price increases.
- A farmer is confident his fields will yield \$200,000 worth of corn in the next two months. He is happy with the current price for corn. Thus, would like to “lock in” the current price.

13.7.2 Portfolio Matching, Tracking, and Program Trading

Given a benchmark portfolio B , we say we construct a matching or tracking portfolio if we construct a new portfolio C that has stochastic behavior very similar to B , but excludes certain instruments in B . Example situations are:

- A portfolio manager does not wish to look bad relative to some well-known index of performance such as the S&P 500, but for various reasons cannot purchase certain instruments in the index.
- An arbitrageur with the ability to make fast, low-cost trades wants to exploit market inefficiencies (i.e., instruments mispriced by the market). If he can construct a portfolio that perfectly matches the future behavior of the well-defined portfolio, but costs less today, then he has an arbitrage profit opportunity (if he can act before this “mispricing” disappears).
- A retired person is concerned mainly about inflation risk. In this case, a portfolio that tracks inflation is desired.

As an example of (a), a certain so-called “green” mutual fund will not include in its portfolio companies that derive more than 2% of their gross revenues from the sale of military weapons, own directly or operate nuclear power plants, or participate in business related to the nuclear fuel cycle.

The following table, for example, compares the performance of six Vanguard portfolios with the indices the portfolios were designed to track; see Vanguard (1995):

Total Return Six Months Ended June 30, 1995			
Vanguard Portfolio Name	Portfolio Growth	Comparative Growth Index	Index Name
500 Portfolio	+20.1%	+20.2%	S&P500
Growth Portfolio	+21.1	+21.2	S&P500/BARRA Growth
Value Portfolio	+19.1	+19.2	S&P500/BARRA Value
Extended Market Portfolio	+17.1%	+16.8%	Wilshire 4500 Index
SmallCap Portfolio	+14.5	+14.4	Russell 2000 Index
Total Stock Market Portfolio	+19.2%	+19.2%	Wilshire 5000 Index

Notice, even though there is substantial difference in the performance of the portfolios, each matches its benchmark index quite well.

13.8 Methods for Constructing Benchmark Portfolios

A variety of approaches has been used for constructing hedging and matching portfolios. For matching portfolios, an intuitive approach has been to generalize the Markowitz model, so the objective is to minimize the variance in the difference in return between the target portfolio and the tracking portfolio.

A useful way to think about hedging or matching of a benchmark is to think of it as our being forced to include the benchmark or its negative in our portfolio. Suppose the benchmark is a simple index such as the S&P500. If our measure of risk is variance, then proceed as follows:

1. Include the benchmark in the covariance matrix just like any other instrument, except do not include it in the budget constraint. We presume we have a budget of \$1 to invest in the controllable, non-benchmark portion of our portfolio.
2. To get a “matching” portfolio (e.g., one that mimics the S&P 500), set the value of the benchmark factor to -1 . The essential effect is the off diagonal covariance terms are negated in the row/column of the benchmark factor. Effectively, we have shorted the factor. If we can get the total variance to zero, we have perfectly matched the randomness of the benchmark.
3. To get a “hedging” portfolio (e.g., one as negatively correlated with the S&P 500 as possible), set the value of the benchmark factor to $+1$. Thus, we will compose the rest of the portfolio to counteract the effect of the factor we are stuck with having in the portfolio.

One might even want to drop the budget constraint. The solution will then tell you how much to invest in the controllable portfolio to get the best possible hedge or match per \$ of the benchmark.

The following model illustrates the extension of the Markowitz approach to the hedging case where we want to “cancel out” some benchmark. In the case of *GMC*, it could be that our decision maker works for *GMC* and thus has his fortunes unavoidably tied to those of *GMC*. He might wish to find a portfolio negatively correlated with *GMC*:

```

MODEL:
!Generic Markowitz portfolio Hedging model(PORTHEDG);
! We want to hedge the first or "benchmark" asset
  with the remaining ones;
SETS:
  ASSET/ GMC ATT USX/: RET, X;
  TMAT( ASSET, ASSET) | &1 #GE# &2: COV;
ENDSETS
DATA:
! The expected returns;
  RET = 1.21367, 1.089083, 1.23458;
! Covariance matrix;
  COV =
      .05839170
      .01240721 .01080754
      .05542639 .01307513 .09422681;
! The desired return;
  TARGET = 1.15;
ENDDATA
!-----;
! Min the var in portfolio return;
[OBJ] MIN= ( @SUM( ASSET( I):
              COV( I, I) * X( I)^2) +
            2 * @SUM( TMAT( I, J) | I #NE# J:
              COV( I, J) * X( I) * X( J)) ) ;
!We are stuck with the first asset in the portfolio;
X( 1) = 1;
! Budget constraint(applies to remaining assets);
[BUDGET] @SUM( ASSET( I) | I #GT# 1: X( I)) = 1;
! Return requirement(applies to remaining assets);
[RETURN] @SUM( ASSET( I) | I #GT# 1:
              RET( I) * X( I)) >= TARGET;
END

```

The solution is:

```

Optimal solution found at step:      4
Objective value:                    0.1457632
Variable      Value      Reduced Cost
X( GMC)       1.000000      0.0000000
X( ATT)       0.5813178     0.0000000
X( USX)       0.4186822     0.0000000

```

Thus, our investor puts more of the portfolio in *ATT* than in *USX* (whose fortunes are more closely tied to those of *GMC*).

The following model illustrates the extension of the Markowitz approach to the matching case where we want to construct a portfolio that *mimics or matches* a benchmark portfolio. In this case, we want to match the S&P500, but limit ourselves to investing in only *ATT*, *GMC*, and *USX*:

```

MODEL:
!Gen. Markowitz portfolio Matching model(PORTMTCH);
! We want to match the first or "benchmark" asset
  with the remaining ones;
SETS:
  ASSET/ SP500 ATT GMC USX/: RET, X;
  TMAT( ASSET, ASSET) | &1 #GE# &2: COV;
ENDSETS
DATA:
! The expected returns;
  RET = 1.191458 1.089083, 1.21367, 1.23458;
! Covariance matrix;
  COV =
    .02873661
    .01266498 .01080754
    .03562763 .01240721 .05839170
    .04378880 .01307513 .05542639 .09422681;
! The desired return;
  TARGET = 1.191458;
ENDDATA
!-----;
! Min the var in portfolio return;
[OBJ] MIN = (@SUM( ASSET(I): COV(I, I) * X( I)^2)
  + 2 * @SUM( TMAT( I, J) | I #NE# J:
    COV( I, J) * X( I) * X( J))) ;
!Matching is equivalent to being short the benchmark;
  X( 1) = -1;
  @FREE( X( 1));
! Budget constraint(applies to remaining assets);
[BUDGET] @SUM( ASSET( I)| I #GT# 1: X( I)) = 1;
! Return requirement(applies to remaining assets);
[RETURN] @SUM( ASSET( I)| I #GT# 1:
  RET( I) * X( I)) >= TARGET;
END

```

The solution is:

```

Optimal solution found at step:          4
Objective value:          0.5245968E-02
Variable          Value          Reduced Cost
X( SP500)         -1.000000         0.0000000
X( ATT)           0.2276635         0.0000000
X( GMC)           0.4781277         0.0000000
X( USX)           0.2942089         -0.1266506E-07

```

13.8.1 Scenario Approach to Benchmark Portfolios

If we use the scenario approach, then the hedging model looks as follows:

```

MODEL:      ! (PRTSHDGE);
! Scenario portfolio model, Hedge 1st asset;
! Minimize the variance;
SETS:
  SCENE/1..12/: PRB, R, DVU, DVL;
  ASSET/ GMT, ATT, USX/: X;
  SXA( SCENE, ASSET): VE;
ENDSETS
DATA:
! Data based on original Markowitz example;
VE =
  1.225  1.300  1.149
  1.290  1.103  1.260
  1.216  1.216  1.419
  0.728  0.954  0.922
  1.144  0.929  1.169
  1.107  1.056  0.965
  1.321  1.038  1.133
  1.305  1.089  1.732
  1.195  1.090  1.021
  1.390  1.083  1.131
  0.928  1.035  1.006
  1.715  1.176  1.908;
! All scenarios happen to be equally likely;
PRB= .0833333 .0833333 .0833333 .0833333 .0833333
     .0833333 .0833333 .0833333 .0833333 .0833333
     .0833333 .0833333;
! The desired return;
TARGET = 1.15;
ENDDATA
! Minimize risk;
[OBJ] MIN = @SUM( SCENE: PRB * ( DVL + DVU) ^ 2);
!We are stuck with having asset 1 in the portfolio;
X( 1) = 1;
!Compute hedging portfolio value under each scenario;
@FOR( SCENE( S):
  R( S)=
    @SUM( ASSET( J)| J #GT# 1: VE( S, J) * X( J));
! Measure deviations hedge + benchmark from target;
  DVU( S) - DVL( S) =
    ( R(S) + VE( S, 1))/ 2 - TARGET;
);
! Budget constraint(applies to remaining assets);
[BUDGET] @SUM( ASSET( J)| J #GT# 1: X( J)) = 1;
! Compute expected value of ending position;
[DEFAVG] AVG = @SUM( SCENE: PRB * R);
! Target ending value;
[RET] AVG > TARGET;
END

```

With a solution:

```

Optimal solution found at step:      4
Objective value:                    0.3441714E-01
Variable      Value      Reduced Cost
X( GMT)      1.000000      0.0000000
X( ATT)      0.5813256      0.0000000
X( USX)      0.4186744      0.0000000

```

Notice we get the same portfolio as with the Markowitz model.

A scenario model for constructing a portfolio matching the S&P500 looks as follows:

```

MODEL:
! Scenario model, Match 1st asset(PRTSMTCH);
! Minimize the variance;
SETS:
  SCENE/1..12/: PRB, R, DVU, DVL;
  ASSET/ SP500 ATT GMT USX/: X;
  SXA( SCENE, ASSET): VE;
ENDSETS
DATA:
! Data based on original Markowitz example;
  VE =
!   S&P500   ATT   GMC   USX;
  1.258997   1.3   1.225  1.149
  1.197526   1.103  1.29   1.26
  1.364361   1.216  1.216  1.419
  0.919287   0.954  0.728  0.922
  1.05708    0.929  1.144  1.169
  1.055012   1.056  1.107  0.965
  1.187925   1.038  1.321  1.133
  1.31713    1.089  1.305  1.732
  1.240164   1.09   1.195  1.021
  1.183675   1.083  1.39   1.131
  0.990108   1.035  0.928  1.006
  1.526236   1.176  1.715  1.908;
! All scenarios happen to be equally likely;
PRB= .0833333 .0833333 .0833333 .0833333 .0833333
     .0833333 .0833333 .0833333 .0833333 .0833333
     .0833333 .0833333;
! The desired return;
  TARGET = 1.191458;
ENDDATA
! Minimize risk;
[OBJ] MIN = @SUM( SCENE: PRB * ( DVL + DVU) ^ 2);
! Compute portfolio value under each scenario;
@FOR( SCENE( S):
  R( S) =
    @SUM( ASSET( J)| J #GT# 1: VE( S, J) * X( J));
! Measure deviations of portfolio from benchmark;
  DVU( S) - DVL( S) = ( R( S) - VE( S, 1));
);
! Budget constraint(applies to remaining assets);
[BUDGET] @SUM( ASSET( J)| J #GT# 1: X( J)) = 1;

```

```

! Compute expected value of ending position;
[DEFAVG] AVG = @SUM( SCENE: PRB * R);
! Target ending value;
[RET] AVG > TARGET;
END

```

The solution is:

```

Optimal solution found at step:          7
Objective value:                        0.4808974E-02
Variable          Value          Reduced Cost
X( SP500)         0.0000000        0.0000000
X( ATT)           0.2276583        0.0000000
X( GMT)           0.4781151        0.0000000
X( USX)           0.2942266        0.0000000

```

Notice we get the same portfolio as with the Markowitz model.

The two scenario models both used variance for the measure of risk relative to the benchmark. It is easy to modify them, so more asymmetric risk measures, such as downside risk, could be used.

13.8.2 Efficient Benchmark Portfolios

We say a portfolio is on the efficient frontier if there is no other portfolio that has both higher expected return and lower risk.

Let:

r_i = expected return on asset i ,
 t = an arbitrary target return for the portfolio.

A portfolio, with weight m_i on asset i , is efficient if there exists some target t for which the portfolio is a solution to the problem:

Minimize risk
subject to

$$\sum_{i=0}^n m_i = 1 \quad (\text{budget constraint})$$

$$\sum_{i=0}^m r_i m_i \geq t \quad (\text{return target constraint}).$$

Portfolio managers are frequently evaluated on their performance relative to some benchmark portfolio. Let b_i = the weight on asset i in the benchmark portfolio. If the benchmark portfolio is not on the efficient frontier, then an interesting question is: What are the weights of the portfolio on the efficient frontier that is closest to the benchmark portfolio in the sense that the risk of the efficient portfolio relative to the benchmark is minimized?

There is a particularly simple answer when the measure of risk is portfolio variance, there is a risk-free asset, borrowing is allowed at the risk-free rate, and short sales are permitted. Let m_0 = the weight on the risk-free asset. An elegant result, in this case, is that there is a so-called “market” portfolio with weights m_i on asset i , such that effectively only m_0 varies as the return target varies. Specifically, there are constants m_i , for $i = 1, 2, \dots, n$, such that the weight on asset i is simply $(1 - m_0) \times m_i$. Define:

$$q = 1 - m_0 = \text{weight to put on the market portfolio,}$$

$$R_i = \text{random return on asset } i.$$

Then the variance of any efficient portfolio relative to the benchmark portfolio can be written as:

$$\begin{aligned} & \text{var}\left(\sum_{i=1}^n R_i [qm_i - b_i]\right) \\ &= \sum_{i=1}^n (qm_i - b_i)^2 \text{var}(R_i) + 2 \sum_{j>i} (qm_i - b_i)(qm_j - b_j) \text{Cov}(R_i, R_j). \end{aligned}$$

Setting the derivative of this expression with respect to q equal to zero gives the result:

$$q = \frac{\sum_{i=1}^n m_i b_i \text{var}(R_i) + \sum_{j>i} (m_i b_j m_j b_i) \text{Cov}(R_i, R_j)}{\sum_{i=1}^n m_i^2 \text{var}(R_i) + 2 \sum_{i>j} m_i m_j \text{Cov}(R_i, R_j)}$$

For example, if the benchmark portfolio is on the efficient frontier with weight b_0 on the risk-free asset, then $b_i = (1 - b_0)m_i$ and therefore $q = 1 - b_0$.

Thus, a manager who is told to outperform the benchmark portfolio $\{b_0, b_1, \dots, b_n\}$ should perhaps, in fact, be compensated according to his performance relative to the efficient portfolio given by q above.

13.8.3 Efficient Formulation of Portfolio Problems

The amount of time it takes to solve a mathematical model may depend dramatically on how the model is formulated. This phenomenon is well known in integer programming circles. Below, we illustrate the same phenomenon for nonlinear programs. We give several different, but mathematically equivalent, formulations of a portfolio optimization model.

Formulation 1

$$\text{Minimize } \sum_{i=1}^n \sum_{j=1}^n q_{ij} x_i x_j$$

subject to

$$\sum_{j=1}^n x_j = 1$$

$$\sum_{j=1}^n r_j x_j = r_0$$

Formulation 2

We can exploit the fact that the covariance matrix is symmetric to rewrite the objective as:

$$\text{Min } \sum_{i=1}^n x_i (q_{ii} x_i + 2 \sum_{j=i+1}^n q_{ij} x_j)$$

subject to

$$\sum_{j=1}^n x_j = 1$$

$$\sum_{j=1}^n r_j x_j = r_0$$

Formulation 3

We can separately compute the term multiplying x_i in the objective to get the formulation:

$$\text{Minimize } \sum_{i=1}^n x_i w_i$$

subject to

For each i ;

$$w_i = q_{ii} x_i + 2 \sum_{j=i+1}^n q_{ij} x_j \quad w_i \text{ a free variable}$$

$$\sum_{j=1}^n x_j = 1$$

$$\sum_{j=1}^n r_j x_j = r_0$$

We solved a specific instance of these formulations for a data set based on the performance of 19 stocks on the New York Stock exchange (IBM, Xerox, ATT, etc.). These models were solved as general nonlinear programs. The fact they were quadratic programs was not exploited.

The solution time in seconds for each formulation was:

Formulation	Time in seconds
1	2.16
2	1.5
3	0.82

Why the dramatic differences in solution time?

The advantage of formulation (2) over (1) is relatively obvious. Each function evaluation of the objective in (1) requires approximately $2 \times n \times n$ multiplications (2 multiplications for each of approximately $n \times n$ terms). For (2), the equivalent figure is about $n + n \times n/2$ multiplications.

Formulation (3) has essentially the same number of multiplications as (2). However, about $n \times n/2$ of them appear in linear constraints. The number of constraints has dramatically increased. However, these constraints are linear and the technology for efficiently processing linear constraints is well developed.

13.9 Cholesky Factorization for Quadratic Programs

There is another formulation comparable to formulation (3), but even more compact. Given a covariance matrix $\{q_{ij}\}$, one can compute its “square root,” the so-called Cholesky factorization, to give a lower triangular matrix $\{L_{ij}\}$. The new formulation is then:

$$\begin{aligned} &\text{Minimize } \sum_{j=1}^n w_j^2 \\ &\text{subject to} \\ &\text{For each } j: \\ &w_j = \sum_{i=j+1}^n L_{ij} x_i, \quad w_j \text{ a free variable} \\ &\sum_{j=1}^n x_j = 1 \\ &\sum_{j=1}^n r_j x_j = r_0 \end{aligned}$$

Notice it is approximately identical in structure to formulation (3) except it has only n rather than $2n$ variables in the objective.

For the reader comfortable with matrix notation, the transformation is easy to explain. Given the covariance matrix Q and a lower triangular matrix L such that:

$$L L' = Q, \text{ where } L' \text{ denotes transpose,}$$

our objective is to:

$$\text{Minimize } x Q x' = x L L' x'$$

If we set $w = x L$, then our objective is simply:

$$\begin{aligned} &\text{Minimize } w w' \\ &\text{subject to} \\ &w = x L. \end{aligned}$$

A LINGO model using Cholesky decomposition and applied to our three-asset example is shown below:

```
MODEL:! Cholesky factorization Portfolio model;
SETS:
  ASSET: AMT, RET, CW;
  COVMAT( ASSET, ASSET): VARIANCE;
  MAT(ASSET,ASSET)| &1 #GE# &2: L; !Cholesky factor;
ENDSETS
DATA:
  ASSET =      ATT      GMC      USX;
!Covariance matrix and expected returns;
VARIANCE = .01080754 .01240721 .01307513
           .01240721 .05839170 .05542639
           .01307513 .05542639 .09422681;
  RET = .0890833 .213667 .234583;
ENDDATA
! Minimize variance;
[VAR] MIN = @SUM( ASSET( I): CW( I) * CW( I));
```

```

! Use exactly 100% of the starting budget;
[BUDGET] @SUM( ASSET: AMT) = 1;
! Required wealth at end of period;
[RETURN] @SUM( ASSET: AMT * RET) > .15;
! Compute contributions to variance, CW();
@FOR( ASSET( J):
    @FREE( CW( J));
    CW( J) = @SUM( MAT( I, J): L( I, J) * AMT( I));
);
!Compute the Cholesky factor L, so LL'= VARIANCE;
@FOR( ASSET( I):
    @FOR( MAT( I, J)| J #LT# I:
L(I,J) = ( VARIANCE( I, J) - @SUM( MAT( I, K)|
    K #LT# J: L( I, K) * L( J, K)))/ L( J, J);
);
L(I,I) = ( VARIANCE( I, I) - @SUM( MAT( I, K)|
    K #LT# I: L( I, K) * L( I, K)))^.5;
);
END

```

Part of the solution report is shown below:

```

Optimal solution found at step:          4
Objective value:          0.2241375E-01

```

Variable	Value	Reduced Cost
AMT(ATT)	0.5300926	0.0000000
AMT(GMC)	0.3564106	0.0000000
AMT(USX)	0.1134968	0.4492217E-08
RET(ATT)	0.8908330E-01	0.0000000
RET(GMC)	0.2136670	0.0000000
RET(USX)	0.2345830	0.0000000
CW(ATT)	0.1119192	0.0000000
CW(GMC)	0.9671834E-01	0.0000000
CW(USX)	0.2309568E-01	0.0000000
VARIANCE(ATT, ATT)	0.1080754E-01	0.0000000
VARIANCE(ATT, GMC)	0.1240721E-01	0.0000000
VARIANCE(ATT, USX)	0.1307513E-01	0.0000000
VARIANCE(GMC, ATT)	0.1240721E-01	0.0000000
VARIANCE(GMC, GMC)	0.5839170E-01	0.0000000
VARIANCE(GMC, USX)	0.5542639E-01	0.0000000
VARIANCE(USX, ATT)	0.1307513E-01	0.0000000
VARIANCE(USX, GMC)	0.5542639E-01	0.0000000
VARIANCE(USX, USX)	0.9422681E-01	0.0000000
L(ATT, ATT)	0.1039593	0.0000000
L(GMC, ATT)	0.1193468	0.0000000
L(GMC, GMC)	0.2101144	0.0000000
L(USX, ATT)	0.1257716	0.0000000
L(USX, GMC)	0.1923522	0.0000000
L(USX, USX)	0.2034919	0.0000000

Row	Slack or Surplus	Dual Price
VAR	0.2241375E-01	-1.000000
BUDGET	0.0000000	0.8255034E-02
RETURN	0.0000000	-0.3538836

13.10 Problems

1. You are considering three stocks, *IBM*, *GM*, and Georgia-Pacific (*GP*), for your stock portfolio. The covariance matrix of the yearly percentage returns on these stocks is estimated to be:

	IBM	GM	GP
IBM	10	2.5	1
GM	2.5	4	1.5
GP	1	1.5	9

Thus, if equal amounts were invested in each, the variance would be proportional to $10 + 4 + 9 + 2(2.5 + 1 + 1.5)$. The predicted yearly percentage returns for *IBM*, *GM*, and *GP* are 9, 6 and 5, respectively. Find a minimum variance portfolio of these three stocks for which the yearly return is at least 7, at most 80% of the portfolio is invested in *IBM*, and at least 10% is invested in *GP*.

2. Modify your formulation of problem 1 to incorporate the fact that your current portfolio is 50% *IBM* and 50% *GP*. Further, transaction costs on a buy/sell transaction are 1% of the amount traded.
3. The manager of an investment fund hypothesizes that three different scenarios might characterize the economy one year hence. These scenarios are denoted *Green*, *Yellow* and *Red* and subjective probabilities 0.7, 0.1, and 0.2 are associated with them. The manager wishes to decide how a model portfolio should be allocated among stocks, bonds, real estate and gold in the face of these possible scenarios. His estimated returns in percent per year as a function of asset and scenario are given in the table below:

	Stocks	Bonds	Real Estate	Gold
Green	9	7	8	-2
Yellow	-1	5	10	12
Red	10	4	-1	15

Formulate and solve the asset allocation problem of minimizing the variance in return subject to having an expected return of at least 6.5.

4. Consider the ATT/GMC/USX portfolio problem discussed earlier. The desired or target rate of return in the solved model was 15%.
- Suppose we desire a 16% rate of return. Using just the solution report, what can you predict about the standard deviation in portfolio return of the new portfolio?
 - We illustrated the situation where the opportunity to invest money risk-free at 5% per year becomes available. That is, this fourth option has zero variance and zero covariance. Now, suppose the risk-free rate is 4% per year rather than 5%. As before, there is no limit on how much can be invested at 4%. Based on only the solution report available for the original version of the problem (where the desired rate of return is 15% per year), discuss whether this new option is attractive when the desired return for the portfolio is 15%.
 - You have \$100,000 to invest. What modifications would need to be made to the original ATT/GMC/USX model, so the answers in the solution report would come in the appropriate units (e.g., no multiplying of the numbers in the solution by 100,000)?
 - What is the estimated standard deviation in the value of your end-of-period portfolio in (c) if invested as the solution recommends?

Multiple Criteria and Goal Programming

14.1 Introduction

Until now, we have assumed a single objective or criterion. In reality, however, there may be two or more measures of goodness. Our life becomes more difficult, or at least more interesting, if these multiple criteria are incommensurate (i.e., it is difficult to combine them into a single criterion). The overused phrase for lamenting the difficulty of such situations is “You can’t mix apples and oranges”.

Some examples of incommensurate criteria are:

- risk vs. return on investment,
- short-term profits vs. long-term growth of a firm,
- cost vs. service by a government agency,
- the treatment of different individuals under some policy of an administrative agency (e.g., rural vs. urban citizens, residents near an airport vs. travelers using an airport, and fishermen vs. water transportation companies vs. farmers using irrigation near a large lake).

Multi-criteria situations can be classified into several categories:

1. Criteria are intrinsically different (e.g., risk vs. return, cost vs. service).
 - a) Weights or trade-off rates can be determined;
 - b) Criteria can be strictly ordered by importance. We have so-called preemptive objectives.
2. Criteria are intrinsically similar (i.e., in some sense they should have equal weight).

A rich source of multi-criteria problems is the design and operation of public works. A specific example is the huge “Three Gorges” dam on the Yangtze River in China. Interested parties include: (a) industrial users of electricity, who would like the average water level in the dam to be high, so as to maximize the amount of electricity that can be generated; (b) farmers downstream from the dam, who would like the water level in the dam to be maintained at a low level, so unexpected large rainfalls can be accommodated without overflow and flooding; (c) river shipping interests, who would like the lake level to be allowed to fluctuate as necessary, so as to maintain a steady flow rate out of the dam,

thereby allowing year round river travel by large ships below the dam; (d) lake fishermen and recreational interests, who would like the flow rate out of the dam to be allowed to fluctuate as necessary, so as to maintain a steady lake level; and (e) environmental interests, who did not want the dam built in the first place. For the Three Gorges dam in particular, flood control interests have argued for having the water level behind the dam held at 459 feet above sea level just before the rainy season, so as to accommodate storm runoff (see, for example, Fillon (1996)). Electricity generation interests, however, have argued for a water level of 574 feet above sea level to generate more electricity.

14.1.1 Alternate Optima and Multicriteria

If you have a model with alternate optimal solutions, this is nature's way of telling you that you have multiple criteria. You should probably look at your objective function more closely and add more detail. Users do not like alternate optima. If there are alternate optima, the typical solution method will essentially choose among them randomly. If people's jobs or salaries depend upon the "flip of a coin" in your analysis, they are going to be unhappy. Even if careers are not at stake, alternate optima are at least a nuisance. People find it disconcerting if they get different answers (albeit with the same objective value) when they solve the same problem on different computers.

One resolution of alternate optima that might occur to some readers is to take the average of all distinct alternate optima and use this average solution as the final, unique, well-defined answer. Unfortunately, this is usually not practical because:

- a) it may be difficult to enumerate all alternate optima, and
- b) the average solution may be unattractive or even infeasible if the model involves integer variables.

14.2 Approaches to Multi-criteria Problems

There is a variety of approaches to dealing with multiple criteria. Some of the more practical ones are described below.

14.2.1 Pareto Optimal Solutions and Multiple Criteria

A solution to a multi-criteria problem is said to be *Pareto optimal* if there is no other solution that is at least as good according to all criteria and strictly better according to at least one criterion. A Pareto optimal solution is not dominated by any other solution. Clearly, we want to consider only Pareto optimal solutions. If we do not choose our criteria carefully, we might find ourselves recommending solutions that are not Pareto optimal. There are computer programs for multi-criteria linear programming that will generate all the undominated extreme solutions. For a small problem, a decision maker could simply choose the most attractive extreme solution based on subjective criteria. For large problems, the number of undominated extreme solutions may easily exceed 100, so this approach may be overwhelming.

14.2.2 Utility Function Approach

A superficially attractive solution of the multi-criteria problem is the definition of a utility function. If the decision variables are x_1, x_2, \dots, x_n , we "simply" construct the utility function $u(x_1, x_2, \dots, x_n)$ which computes the value or utility of any possible combination of values for the vector x_1, x_2, \dots, x_n . This is a very useful approach for *thinking* about optimization. However, it has several practical limitations: (a) it may take a lot of work to construct it, and (b) it will probably be highly nonlinear. Feature (b) means we probably cannot use LP to solve the problem.

14.2.3 Trade-off Curves

If we have only two or three criteria, then the trade-off curve approach has most of the attractive features of the utility function approach, but is also fairly practical. We simply construct a curve, the so-called “efficient frontier”, which shows how we can trade off one criterion for another. One of the most well known settings using a trade-off curve is to describe the relationship between two criteria in a financial portfolio. The two criteria are expected return on investment and risk. We want return to be high and risk to be low. Figure 14.1 shows the typical relationship between risk and return. Each point on the curve is Pareto optimal. That is, for any point on the curve, there is no other point with higher expected return and lower risk.

Even though a decision maker has not gone through the trouble of constructing his utility function, he may be able to look at this trade-off curve and perhaps say: “Gee, I am comfortable with an expected return of 8% with standard deviation of 3%.”

Figure 14.1 Trade-off Curve for Risk and Expected Return

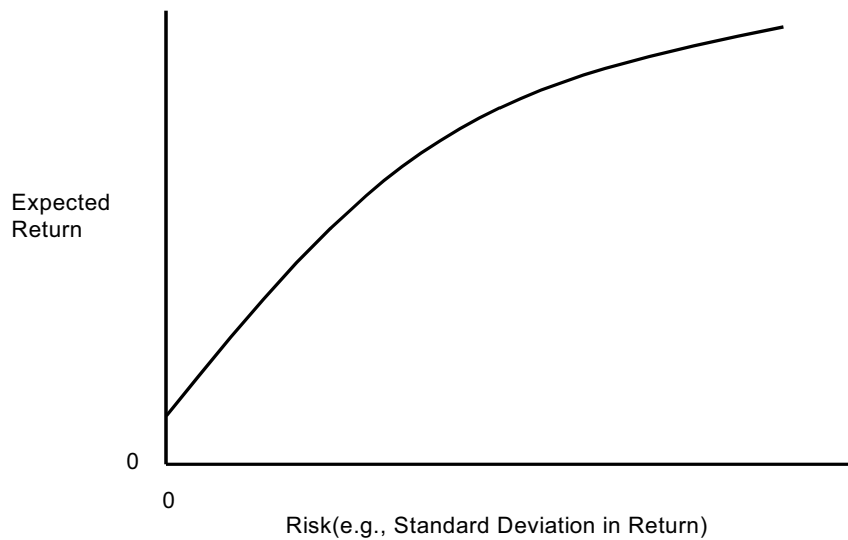

14.2.4 Example: Ad Lib Marketing

Ad Lib is a freewheeling advertising agency that wants to solve a so-called media selection problem for one of its clients. It is considering placing ads in five media: late night TV (*TVL*), prime time TV (*TVP*), billboards (*BLB*), newspapers (*NEW*), and radio (*RAD*). These ads are intended to reach seven different demographic groups.

The following table gives the number of exposures obtained in each of the seven markets per dollar of advertising in each of five media. The second to last row of the table lists the minimum required number of exposures in each of the seven markets. The feeling is that we must reach this minimum number of readers/viewers, regardless of the cost. The last row of numbers is the saturation level for each market. The feeling is that exposure beyond this level is of no value. Exposures between these two limits will be termed useful exposures.

		Exposure Statistics for Ad Lib Marketing						
		Exposure in 1000's per \$1000 Spent						
		Market Group						
		1	2	3	4	5	6	7
TVL			10	4	50	5		2
TVP			10	30	5	12		
BLB		20					5	3
NEW		8					6	10
RAD			6	5	10	11	4	
Minimum Number of Exposures Needed in 1,000's		25	40	60	120	40	11	15
Saturation Level in 1,000's of Exposures		60	70	120	140	80	25	55

How much money should be spent on advertising in each medium? There are really two criteria: (a) cost (which we want to be low), and (b) useful exposures (which we want to be high). At the outset, we arbitrarily decided we would spend no more than \$11,000.

A useful model can be formulated if we define:

Decision variables:

TVL, TVP, etc. = dollars spent in 1,000's on advertising in *TVL, TVP, etc.*;

UX1, UX2, etc. = number of useful excess exposures obtained in market 1, 2, etc., beyond the minimum (i.e., $\min \{\text{saturation level, actual exposures}\} - \text{minimum required}$);

COST = total amount spent on advertising;

USEFULX = total useful exposures.

There will be two main sets of constraints. One set that says:

exposures in a market \geq minimum required + useful excess exposure beyond minimum.

The other says:

useful excess exposures in a market \leq saturation level – minimum required.

An explicit formulation is:

```
[UEXP] MAX = USEFULX ;      ! Maximize useful exposures;
[LIMCOST] COST <= 11; !Limit (in $1,000) on cost;
[LIMEXP]  USEFULX >= 0;! Required exposures;
[DEFCOST] TVL + TVP + BLB + NEW + RAD = COST;
[DEFEXP] UX1 + UX2 + UX3 + UX4 + UX5 + UX6 + UX7 =
        USEFULX;
[MKT1]      20 * BLB + 8 * NEW          - UX1 >= 25;
[MKT2] 10 * TVL + 10 * TVP          + 6 * RAD - UX2 >= 40;
[MKT3]  4 * TVL + 30 * TVP          + 5 * RAD - UX3 >= 60;
[MKT4] 50 * TVL + 5 * TVP          + 10 * RAD - UX4 >= 120;
[MKT5]  5 * TVL + 12 * TVP          + 11 * RAD - UX5 >= 40;
[MKT6]      5 * BLB + 6 * NEW + 4 * RAD - UX6 >= 11;
[MKT7] 2 * TVL + 3 * BLB + 10 * NEW - UX7 >= 15;
[RANGE1] UX1 <= 35;
[RANGE2] UX2 <= 30;
[RANGE3] UX3 <= 60;
[RANGE4] UX4 <= 20;
[RANGE5] UX5 <= 40;
[RANGE6] UX6 <= 14;
[RANGE7] UX7 <= 40;
```

The following is part of the solution to this model:

```
Optimal solution found at step:      15
Objective value:                      196.7626
```

Variable	Value	Reduced Cost
USEFULX	196.7626	0.0000000
COST	11.00000	0.0000000
TVL	1.997602	0.0000000
TVP	3.707434	0.0000000
BLB	2.908873	0.0000000
NEW	0.2278177	0.0000000
RAD	2.158273	0.0000000
UX1	35.00000	0.0000000
UX2	30.00000	0.0000000
UX3	60.00000	0.0000000
UX4	20.00000	0.0000000
UX5	38.21823	0.0000000
UX6	13.54436	0.0000000
UX7	0.0000000	0.7194281E-02
Row	Slack or Surplus	Dual Price
UEXP	196.7626	1.000000
LIMCOST	0.0000000	21.43885
LIMEXP	196.7626	0.000000
DEFCOST	0.0000000	21.43885
DEFEXP	0.0000000	-1.000000

Notice we advertise up to the saturation level in markets 1 to 4. In market 7, we advertise just enough to achieve the minimum required.

If you change the cost limit (initially at 11) to various values ranging from 6 to 14 and plot the maximum possible number of useful exposures, you get a trade-off curve, or efficient frontier, shown in the Figure 14.2:

Figure 14.2 Trade-off Between Exposures and Advertising

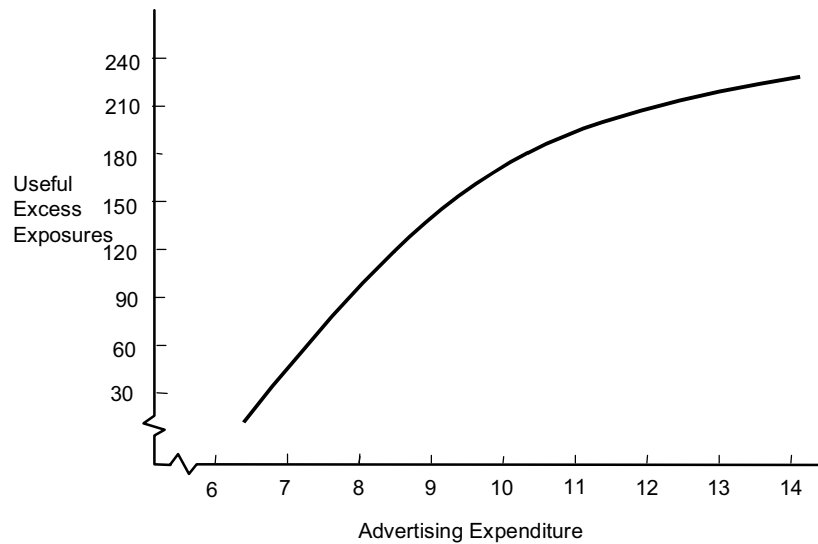

14.3 Goal Programming and Soft Constraints

Goal Programming is closely related to the concept of multi-criteria as well as a simple idea that we dub “soft constraints”. Soft constraints and Goal Programming are a response to the following two “laws of the real world”.

In the real world:

- 1) there is always a feasible solution;
- 2) there are no alternate optima.

In practical terms, (1) means a good manager (or one wishing to at least keep a job) never throws up his or her hands in despair and says “no feasible solution”. Law (2) means a typical decision maker will never be indifferent between two proposed courses of action. There are always sufficient criteria to distinguish some course of action as better than all others.

From a model perspective, these two laws mean a well-formulated model (a) always has a feasible solution and (b) does not have alternate optima.

14.3.1 Example: Secondary Criterion to Choose Among Alternate Optima

Here is a standard, seven-day/week staffing problem similar to that discussed in Chapter 7. The variables: M, T, W, R, F, S, N , denote the number of people starting their five-day work week on Monday, Tuesday, Wednesday, Thursday, Friday, Saturday, or Sunday, respectively:

```

MIN = 9*M + 9*T + 9*W + 9*R + 9*F + 9*S + 9*N;
[MON]  M          + R + F + S + N >= 3;
[TUE]  M + T          + F + S + N >= 3;
[WED]  M + T + W          + S + N >= 8;
[THU]  M + T + W + R          + N >= 8;
[FRI]  M + T + W + R + F          >= 8;
[SAT]          T + W + R + F + S          >= 3;
[SUN]          W + R + F + S + N >= 3;
END

```

When solved, we get the following solution:

```

Optimal solution found at step:      6
Objective value:      72.00000
Variable      Value      Reduced Cost
M      5.000000      0.000000
T      0.000000      0.000000
W      3.000000      0.000000
R      0.000000      0.000000
F      0.000000      9.000000
S      0.000000      9.000000
N      0.000000      0.000000
Row      Slack or Surplus      Dual Price
1      72.00000      1.000000
MON      2.000000      0.000000
TUE      2.000000      0.000000
WED      0.000000      0.000000
THU      0.000000      -9.000000
FRI      0.000000      0.000000
SAT      0.000000      0.000000
SUN      0.000000      0.000000

```

Notice there may be alternate optima (e.g., the slack and dual price in row “WED” are both zero). This solution puts all the surplus capacity on Saturday and Sunday. The different optima might distribute the surplus capacity in different ways over the days of the week. Saturday and Sunday have a lot of excess capacity while the very similar days, Monday and Tuesday, have no surplus capacity.

In terms of multiple criteria, we might say:

- our most important criterion is to minimize total staffing cost;
- our secondary criterion is to have a little extra capacity, specifically one unit, each day if it will not hurt criterion 1.

To encourage more equitable distribution, we add some “excess” variables (XM , XT , etc.) that give a tiny credit of -1 for each surplus up to at most 1 on each day. The modified formulation is:

```

MODEL:
MIN = 9*M + 9*T + 9*W + 9*R + 9*F + 9*S + 9*N
      - XM - XT - XW - XR - XF - XS - XN;
[MON] M           + R   + F   + S   + N   - XM ≥ 3;
[TUE] M + T           + F   + S   + N   - XT ≥ 3;
[WED] M + T   + W           + S   + N   - XW ≥ 8;
[THU] M + T   + W   + R           + N   - XR ≥ 8;
[FRI] M + T   + W   + R   + F           - XF ≥ 8;
[SAT]   T   + W   + R   + F   + S           - XS ≥ 3;
[SUN]           W   + R   + F   + S   + N   - XN ≥ 3;
[N9]   XM ≤ 1;
[N10]  XT ≤ 1;
[N11]  XW ≤ 1;
[N12]  XR ≤ 1;
[N13]  XF ≤ 1;
[N14]  XS ≤ 1;
[N15]  XN ≤ 1;
END

```

The solution now is:

```

Optimal solution found at step:      19
Objective value:                    68.00000

```

Variable	Value	Reduced Cost
M	4.000000	0.000000
T	0.000000	0.000000
W	4.000000	0.000000
R	0.000000	1.000000
F	0.000000	8.000000
S	0.000000	8.000000
N	0.000000	1.000000
XM	1.000000	0.000000
XT	1.000000	0.000000
XW	0.000000	0.000000
XR	0.000000	6.000000
XF	0.000000	0.000000
XS	1.000000	0.000000
XN	1.000000	0.000000

Notice, just as before, we still hire a total of eight people, but now the surplus is evenly distributed over the four days M , T , S , and N . This should be a more attractive solution.

14.3.2 Preemptive/Lexico Goal Programming

The above approach required us to choose the proper relative weights for our two objectives, cost and service. In some situations, it may be clear that one objective is orders of magnitude more important than the other. One could choose weights to reflect this (e.g., 99999999 for the first and 0.0000001 for the second), but there are a variety of reasons for not using this approach. First of all, there would probably be numerical problems, especially if there are more than two objectives. A typical computer cannot accurately add numbers that differ by more than 15 orders of magnitude (e.g., 100,000,000 and .0000001).

More importantly, it just seems more straightforward simply to say: “This first objective is far more important than the remaining objectives, the second objective is far more important than the remaining objectives,” etc. This approach is sometimes called Preemptive or Lexico goal programming. The following illustrates for our previous staff-scheduling example. The first model solved places a weight of 1.0 on the more important objective, *COST*, and no weight on the secondary objective, *EXTRA* credit for useful overstaffing:

```
!Example of Lexico-goal programming
MIN = 1 * COST - 0 * EXTRA;
[MON] M          + R + F + S + N - XM >= 3;
[TUE] M + T          + F + S + N - XT >= 3;
[WED] M + T + W          + S + N - XW >= 8;
[THU] M + T + W + R          + N - XR >= 8;
[FRI] M + T + W + R + F          - XF >= 8;
[SAT]          T + W + R + F + S          - XS >= 3;
[SUN]          W + R + F + S + N - XN >= 3;
! Upper limit on creditable excess;
[EXM] XM <= 1;
[EXT] XT <= 1;
[EXW] XW <= 1;
[EXR] XR <= 1;
[EXF] XF <= 1;
[EXS] XS <= 1;
[EXN] XN <= 1;
! Define the two objectives;
[OBJCOST] COST = M + R + F + S + N + T + W;
[OBJXTRA] EXTRA = XM + XT + XW + XR + XF + XS + XN;
END
```

The solution is:

```

Optimal solution found at step:      11
Objective value:      8.000000

Variable      Value      Reduced Cost
COST          8.000000      0.000000
EXTRA         0.000000      0.000000
M             3.000000      0.000000
R             0.000000      0.000000
F             0.000000      0.000000
S             0.000000      1.000000
N             0.000000      1.000000
XM            0.000000      0.000000
T             0.000000      0.000000
XT            0.000000      0.000000
W             5.000000      0.000000
XW            0.000000      0.000000
XR            0.000000      0.000000
XF            0.000000      1.000000
XS            0.000000      0.000000
XN            0.000000      0.000000

Row      Slack or Surplus      Dual Price
1         8.000000          1.000000
MON        0.000000          0.000000
TUE        0.000000          0.000000
WED        0.000000          0.000000
THU        0.000000          0.000000
FRI        0.000000         -1.000000
SAT        2.000000          0.000000
SUN        2.000000          0.000000
EXM        1.000000          0.000000
EXT        1.000000          0.000000
EXW        1.000000          0.000000
EXR        1.000000          0.000000
EXF        1.000000          0.000000
EXS        1.000000          0.000000
EXN        1.000000          0.000000
OBJCOST    0.000000         -1.000000
OBJXTRA    0.000000          0.000000

```

Notice because there is zero weight in the objective, it does not claim any *EXTRA* credit for overstaffing by one unit. This solution starts 3 people on Monday, and 5 people on Wednesday. Thus, there is no overstaffing on Monday, Tuesday, Wednesday, Thursday, and Friday, but both Saturday and Sunday are overstaffed by two each. We can try to distribute the overstaffing more evenly by solving the following model. It fixes the *COST* at the minimum we have just learned, and now maximizes (or minimizes the negative of) the creditable extra staffing:

```

MIN = 0 * COST - 1 * EXTRA;
[MON] M + R + F + S + N - XM >= 3;
[TUE] M + T + F + S + N - XT >= 3;
[WED] M + T + W + S + N - XW >= 8;
[THU] M + T + W + R + N - XR >= 8;
[FRI] M + T + W + R + F - XF >= 8;
[SAT] T + W + R + F + S - XS >= 3;
[SUN] W + R + F + S + N - XN >= 3;
! Upper limit on creditable excess;
[EXM] XM <= 1;
[EXT] XT <= 1;
[EXW] XW <= 1;
[EXR] XR <= 1;
[EXF] XF <= 1;
[EXS] XS <= 1;
[EXN] XN <= 1;
! Define the two objectives;
[OBJCOST] COST = M + R + F + S + N + T + W;
[OBJXTRA] EXTRA = XM + XT + XW + XR + XF + XS + XN;
! Fix the cost at its minimum value;
[FXCOST] COST = 8;
END

```

This gives the solution:

```

Optimal solution found at step: 7
Objective value: -4.000000

```

Variable	Value	Reduced Cost
COST	8.000000	0.000000
EXTRA	4.000000	0.000000
M	4.000000	0.000000
R	0.000000	1.000000
F	0.000000	2.000000
S	0.000000	2.000000
N	0.000000	1.000000
XM	1.000000	0.000000
T	0.000000	0.000000
XT	1.000000	0.000000
W	4.000000	0.000000
XW	0.000000	0.000000
XR	0.000000	0.000000
XF	0.000000	0.000000
XS	1.000000	0.000000
XN	1.000000	0.000000

Row	Slack or Surplus	Dual Price
1	-4.000000	-1.000000
MON	0.000000	0.000000
TUE	0.000000	0.000000
WED	0.000000	-1.000000
THU	0.000000	-1.000000
FRI	0.000000	-1.000000
SAT	0.000000	0.000000
SUN	0.000000	0.000000
EXM	0.000000	1.000000
EXT	0.000000	1.000000
EXW	1.000000	0.000000
EXR	1.000000	0.000000
EXF	1.000000	0.000000
EXS	0.000000	1.000000
EXN	0.000000	1.000000
OBJCOST	0.000000	-3.000000
OBJXTRA	0.000000	1.000000
FXCOST	0.000000	3.000000

Notice this is a different solution. Nevertheless, still with a cost of 8, but with now an *EXTRA* credit for slight overstaffing of 4. This solution starts 4 people on each of Monday and Wednesday. Thus, Wednesday, Thursday, and Friday have no overstaffing, but Monday, Tuesday, Saturday, and Sunday are overstaffed by one each.

14.4 Minimizing the Maximum Hurt, or Unordered Lexico Minimization

There are some situations in which there are a number of parties that, in some sense, are equal. There may be certain side conditions, however, that prevent us from treating them exactly equally. An example is representation in a House of Representatives. Ideally, we would like to have the number of representatives in a state be exactly proportional to the population of the state. Because the House of Representatives is typically limited to a fixed size and we cannot have fractional representatives (although some voters may feel they have encountered such an anomaly), we will find some states have more citizens per representative than others.

In more general settings, an obvious approach for minimizing such inequities is to choose things, so we minimize the maximum inequity or “hurt.” Once we have minimized the worst hurt, the obvious thing is to minimize the second greatest hurt, etc. We will refer to such a minimization as Unordered Lexico Minimization. For example, if there are four parties, and (10, 13, 8, 9) is the vector of taxes to be paid, then we would say the vector (13, 8, 9, 9) is better in the unordered Lexico-min sense. The highest tax is the same for both solutions, but the second highest tax is lower for the second solution.

Serafini (1996) uses this approach in scheduling jobs in a textile factory in northern Italy. Each job has a due-date. If demand and capacity are such that not all jobs can be completed by their due date, then a reasonable objective is to minimize the maximum lateness of any job. A reasonable sub-objective is to minimize the lateness of the second latest job, etc.

14.4.1 Example

This example is based on one in Sankaran (1989). There are six parties and x_i is the assessment to be paid by party i to satisfy a certain community building project. The x_i must satisfy the set of constraints:

- A. $X1 + 2 X2 + 4 X3 + 7 X4 \geq 16$
- B. $2.5 X1 + 3.5 X2 + 5.2 X5 \geq 17.5$
- C. $0.4 X2 + 1.3 X4 + 7.2 X6 \geq 12$
- D. $2.5 X2 + 3.5 X3 + 5.2 X5 \geq 13.1$
- E. $3.5 X1 + 3.5 X4 + 5.2 X6 \geq 18.2$

We would like to minimize the highest assessment paid by anyone. Given that, we would like to minimize the second highest assessment paid by anyone. Given that, we would like to minimize the third highest, etc. The interested reader may try to improve upon the following set of assessments:

$$\begin{aligned} X1 &= 1.5625 \\ X2 &= 1.5625 \\ X3 &= .305357 \\ X4 &= 1.463362 \\ X5 &= 1.5625 \\ X6 &= 1.463362 \end{aligned}$$

There is no other solution in which:

- a) the highest assessment is less than 1.5625, and
- b) the second highest assessment is less than 1.5625, and
- c) the third highest assessment is less than 1.5625, and
- d) the fourth highest assessment is less than 1.463362, etc.

14.4.2 Finding a Unique Solution Minimizing the Maximum

A quite general approach to finding a unique unordered Lexico minimum exists when the feasible region is convex (i.e. any solution that is a positively weighted average of two feasible solutions is also feasible). Thus, problems with integer variables are not convex. Let the vector $\{x_1, x_2, \dots, x_n\}$ denote the cost allocated to each of n parties.

If the feasible region is convex, then there is a unique solution and the following algorithm will find it. Maschler, Peleg, and Shapley (1979) discuss this idea in the game theory setting, where the "nucleolus" is a closely related concept. If the feasible region is not convex (e.g., the problem has integer variables), then the following method is not guaranteed to find the solution. Let S be the original set of constraints on the x 's.

- 1) Let $J = \{1, 2, \dots, n\}$, and $k = 0$; (Note: J is the set of parties for whom we do not yet know the final x_i)
- 2) Let $k = k + 1$;

- 3) Solve the problem:
 Minimize Z
 subject to
 x feasible to S and,
 $Z \geq x_j$ for j in J
 (Note: this finds the minimum, maximum hurt among parties for which we have not yet fixed the x_j 's.);
- 4) Set $Z_k = Z$ of (3), and add to S the constraints:
 $x_j \leq Z_k$ for all j in J ;
- 5) Set $L = \{j \text{ in } J \text{ for which } x_j = Z_k \text{ in (3)}\}$:
 For each j in L :
 Solve:
 Minimize x_j
 subject to
 x feasible to S ;
 If $x_j = Z_k$, then set $J = J - j$, and append to S the constraint $x_j = Z_k$
- 6) If J is not empty, go to (2), else we are done.

To find the minimum maximum assessment for our example problem, we solve the following problem:

```

MODEL:
MIN = Z;
! The physical constraints on the X's;
[A] X1 + 2*X2 + 4*X3 + 7*X4 >= 16;
[B] 2.5*X1 + 3.5*X2 + 5.2*X5 >= 17.5;
[C] 0.4*X2 + 1.3*X4 + 7.2*X6 >= 12;
[D] 2.5*X2 + 3.5*X3 + 5.2*X5 >= 13.1;
[E] 3.5*X1 + 3.5*X4 + 5.2*X6 >= 18.2;
! Constraints to compute the max hurt Z;
[H1] Z - X1 >= 0;
[H2] Z - X2 >= 0;
[H3] Z - X3 >= 0;
[H4] Z - X4 >= 0;
[H5] Z - X5 >= 0;
[H6] Z - X6 >= 0;
END
  
```

Its solution is:

Objective value:		1.5625000
Variable	Value	Reduced Cost
Z	1.5625000	0.0000000
X1	1.5625000	0.0000000
X2	1.5625000	0.0000000
X3	1.5625000	0.0000000
X4	1.5625000	0.0000000
X5	1.5625000	0.0000000
X6	1.5625000	0.0000000

Thus, at least one party will have a “hurt” of 1.5625. Which party or parties will it be?

Because all six x_i 's equal 1.5625, we solve a series of six problems such as the following:

```

MODEL:
MIN = X1;
! The physical constraints on the X's;
[A] X1 + 2*X2 + 4*X3 + 7*X4 >= 16;
[B] 2.5*X1 + 3.5*X2 + 5.2*X5 >= 17.5;
[C] 0.4*X2 + 1.3*X4 + 7.2*X6 >= 12;
[D] 2.5*X2 + 3.5*X3 + 5.2*X5 >= 13.1;
[E] 3.5*X1 + 3.5*X4 + 5.2*X6 >= 18.2;
! Constraints for finding the minmax hurt, Z;
[H1] X1 <= 1.5625000;
[H2] X2 <= 1.5625000;
[H3] X3 <= 1.5625000;
[H4] X4 <= 1.5625000;
[H5] X5 <= 1.5625000;
[H6] X6 <= 1.5625000;
END

```

The solution for the case of $X1$ is:

Objective value:		1.5625000
Variable	Value	Reduced Cost
X1	1.5625000	0.0000000
X2	1.5625000	0.0000000
X3	0.3053573	0.0000000
X4	1.5625000	0.0000000
X5	1.5625000	0.0000000
X6	1.3966350	0.0000000

Thus, there is no solution with all the x_i 's ≤ 1.5625 , but with $X1$ strictly less than 1.5625. So, we can fix $X1$ at 1.5625. Similar observations turn out to be true for $X2$ and $X5$.

So, now we wish to solve the following problem:

```

MODEL:
MIN = Z;
! The physical constraints on the X's;
X1 + 2*X2 + 4*X3 + 7*X4 >= 16;
2.5*X1 + 3.5*X2 + 5.2*X5 >= 17.5;
0.4*X2 + 1.3*X4 + 7.2*X6 >= 12;
2.5*X2 + 3.5*X3 + 5.2*X5 >= 13.1;
3.5*X1 + 3.5*X4 + 5.2*X6 >= 18.2;
! Constraints for finding the minmax hurt, Z;
X1 = 1.5625000;
X2 = 1.5625000;
- Z + X3 <= 0;
- Z + X4 <= 0;
X5 = 1.5625000;
- Z + X6 <= 0;
END

```

Upon solution, we see the second highest “hurt” is 1.4633621:

Objective value:		1.4633621
Variable	Value	Reduced Cost
Z	1.4633621	0.0000000
X1	1.5625000	0.0000000
X2	1.5625000	0.0000000
X3	1.4633621	0.0000000
X4	1.4633621	0.0000000
X5	1.5625000	0.0000000
X6	1.4633621	0.0000000

Any or all of X_3 , X_4 or X_6 could be at this value in the final solution. Which ones? To find out, we solve the following kind of problem for X_3 , X_4 and X_6 :

```

MODEL:
MIN = X3;
! The physical constraints on the X's;
[A] X1 + 2*X2 + 4*X3 + 7*X4 >= 16;
[B] 2.5*X1 + 3.5*X2 + 5.2*X5 >= 17.5;
[C] 0.4*X2 + 1.3*X4 + 7.2*X6 >= 12;
[D] 2.5*X2 + 3.5*X3 + 5.2*X5 >= 13.1;
[E] 3.5*X1 + 3.5*X4 + 5.2*X6 >= 18.2;
! Constraints for finding the minmax hurt, Z;
[H1] X1 = 1.5625000;
[H2] X2 = 1.5625000;
[H3] X3 <= 1.4633621;
[H4] X4 <= 1.4633621;
[H5] X5 = 1.5625000;
[H6] X6 <= 1.4633621;
END

```

The solution, when we minimize X_3 , is:

Objective value:		.3053571400
Variable	Value	Reduced Cost
X3	.30535714	0.0000000
X1	1.5625000	0.0000000
X2	1.5625000	0.0000000
X4	1.4633621	0.0000000
X5	1.5625000	0.0000000
X6	1.4633621	0.0000000

Thus, X_3 need not be as high as 1.4633621 in the final solution. We do find, however, that X_4 and X_6 can be no smaller than 1.4633621.

So, the final problem we want to solve is:

```

MODEL:
MIN = Z;
! The physical constraints on the X's;
[A] X1 + 2*X2 + 4*X3 + 7*X4 >= 16;
[B] 2.5*X1 + 3.5*X2 + 5.2*X5 >= 17.5;
[C] 0.4*X2 + 1.3*X4 + 7.2*X6 >= 12;
[D] 2.5*X2 + 3.5*X3 + 5.2*X5 >= 13.1;
[E] 3.5*X1 + 3.5*X4 + 5.2*X6 >= 18.2;
! Constraints for finding the minmax hurt, Z;
[H1] X1 = 1.5625000;
[H2] X2 = 1.5625000;
[H3] - Z + X3 = 0;
[H4] X4 = 1.4633621;
[H5] X5 = 1.5625000;
[H6] X6 = 1.4633621;
END

```

We already know the solution will be:

Objective value:		.305357140
Variable	Value	Reduced Cost
Z	.30535714	0.0000000
X1	1.5625000	0.0000000
X2	1.5625000	0.0000000
X3	.30535714	0.0000000
X4	1.4633621	0.0000000
X5	1.5625000	0.0000000
X6	1.4633621	0.0000000

The above solution minimizes the maximum X value, as well as the number of X 's at that value. Given that maximum value (of 1.5625), it minimizes the second highest X value, as well as the number at that value; etc.

The approach described requires us to solve a sequence of linear programs. It would be nice if we could formulate a single mathematical program for finding the unordered Lexico-min. There are a number of such formulations. Unfortunately, all of them suffer from numerical problems when implemented on real computers. The formulations assume arithmetic is done with infinite precision; whereas, most computers do arithmetic with at most 15 decimal digits of precision.

14.5 Identifying Points on the Efficient Frontier

Until now, we have considered the problem of how to generate a solution on the efficient frontier. Now, let us take a slightly different perspective and consider the problem: Given a finite set of points, determine which ones are on the efficient frontier. When there are multiple criteria, it is usually impossible to find a single scoring formula to unambiguously rank all the points or players. The following table comparing on-time performance of two airlines (see Barnett, 1994) illustrates some of the issues:

Destination	Alaska Airlines		America West Airlines	
	% Arrivals	No. of Arrivals	% Arrivals	No. of Arrivals
Los Angeles	88.9	559	85.6	811
Phoenix	94.8	233	92.1	5,255
San Diego	91.4	232	85.5	448
San Francisco	83.1	605	71.3	449
Seattle	85.8	2,146	76.7	262
Weighted 5-Airport Average	86.7	3,775	89.1	7,225

The weighted average at the bottom is computed by applying a weight to the performance at airport i proportional to the number of arrivals at that airport. For example, $86.7 = (88.9 \times 559 + \dots + 85.8 \times 2146) / (559 + \dots + 2146)$.

According to this scoring, America West has a better on-time performance than Alaska Airlines. A traveler considering flying into San Francisco, however, would almost certainly prefer Alaska Airlines to America West with respect to on-time performance. In fact, the same argument applies to all five airports. Alaska Airlines dominates America West. How could America West have scored higher? The reason was a different scoring formula was used for each. Also, the airport receiving the most weight in America West's formula, sunny Phoenix, had a better on-time performance by America West than Alaska Airline's performance at its busiest airport, rainy Seattle. One should, in general, be suspicious when different scoring formulae are used for different candidates.

14.5.1 Efficient Points, More-is-Better Case

The previous example was a case of multiple performance dimensions where, for each dimension, the higher the performance number, the better the performance. We will now illustrate a method for computing a single score or number, between 0 and 1, for each player. The interpretation of this number, or efficiency score, will be that a score of 1.0 means the player or organization being measured is on the efficient frontier. In particular, there is no other player better on all dimensions or even a weighted combination of players, so the weighted averages of their performances surpass the given player on every dimension. On the other hand, a score less than 1.0 means either there is some other player better on all dimensions or there is a weighted combination of players having a weighted average performance better on all dimensions.

Define:

r_{ij} = the performance (or reward) of player i on the j^{th} dimension (e.g., the on-time performance of Alaska Airlines in Seattle);

v_j = the weight or value to be applied to the j^{th} dimension in evaluating overall efficiency.

To evaluate the performance of player k , we will do the following in words:

Choose the v_j so as to maximize score (k)

subject to

For each player i (including k):

score (i) ≤ 1 .

More precisely, we want to:

Max $\sum_j v_j r_{kj}$

subject to

For every player i , including k :

$$\sum_j v_j r_{ij} \leq 1$$

For every weight j :

$$v_j \geq e,$$

where e is a small positive number.

The reason for requiring every v_j to be slightly positive is as follows. Suppose player k and some other player t are tied for best on one dimension, say j , but player k is worse than t on all other dimensions. Player k would like to place all the weight on dimension j , so player k will appear to be just as efficient as player t . Requiring a small positive weight on every dimension will reveal these slightly dominated players. Some care should be taken in the choice of the small “infinitesimal” constant e . If it is chosen too large, it may cause the problem to be infeasible. If it is chosen too small, it may be effectively disregarded by the optimization algorithm. From the above, you can observe that it should be bounded by:

$$e \leq 1/\sum_j r_{ij}.$$

See Mehrabian, Jahanshahloo, Alirezaee, and Amin(2000) for a more detailed discussion.

Example

The performance of five high schools in the “three R’s” of “Reading, Writing and Arithmetic” are tabulated below (see *Chicago Magazine*, February 1995):

School	Reading	Writing	Mathematics
Barrington	296	27	306
Lisle	286	27.1	322
Palatine	290	28.5	303
Hersey	298	27.3	312
Oak Park River Forest (OPRF)	294	28.1	301

Hersey, Palatine, and Lisle are clearly on the efficient frontier because they have the highest scores in reading, writing, and mathematics, respectively. Barrington is clearly not on the efficient frontier, because it is dominated by Hersey. What can we say about OPRF?

We formulate OPRF's problem as follows. Notice we have scaled both the reading and math scores, so all scores are less than 100. This is important if one requires the weight for each attribute to be at least some minimum positive value.

```

MODEL:
MAX = 29.4*VR + 28.1*VW + 30.1*VM;
[BAR] 29.6*VR + 27 *VW + 30.6*VM <= 1;
[LIS] 28.6*VR + 27.1*VW + 32.2*VM <= 1;
[PAL] 29 *VR + 28.5*VW + 30.3*VM <= 1;
[HER] 29.8*VR + 27.3*VW + 31.2*VM <= 1;
[OPR] 29.4*VR + 28.1*VW + 30.1*VM <= 1;
[READ] VR >= 0.0005;
[WRIT] VW >= 0.0005;
[MATH] VM >= 0.0005;
END

```

When solved:

```

Optimal solution found at step: 2
Objective value: 1.000000
Variable Value Reduced Cost
VR 0.1725174E-01 0.0000000
VW 0.1700174E-01 0.0000000
VM 0.5000000E-03 0.0000000
Row Slack or Surplus Dual Price
1 1.000000 1.000000
BAR 0.1500157E-01 0.0000000
LIS 0.2975313E-01 0.0000000
PAL 0.0000000 0.0000000
HER 0.6150696E-02 0.0000000
OPR 0.0000000 1.0000000
READ 0.1675174E-01 0.0000000
WRIT 0.1650174E-01 0.0000000
MATH 0.0000000 0.0000000

```

The value is 1.0, and thus, OPRF is on the efficient frontier. It should be no surprise OPRF puts the minimum possible weight on the mathematics score (where it is the lowest of the five).

14.5.2 Efficient Points, Less-is-Better Case

Some measures of performance, such as cost, are of the "less-is-better" nature. Again, we would like to have a measure of performance that gives a score of 1.0 for a player on the efficient frontier, less than 1.0 for one that is not.

Define:

c_{ij} = performance of player i on dimension j ;
 w_j = weight to be applied to the j^{th} dimension.

To evaluate the performance of player k , we want to solve a problem of the following form:

Choose weights w_j , so as to maximize the minimum weighted score,
 subject to
 the weighted score of player $k = 1$.

If the objective function value from this problem is less than 1, then player k is inefficient, because there is no set of weights such that player k has the best score. More precisely, we want to solve:

$$\begin{array}{l} \text{Max } z \\ \text{subject to} \\ \sum_j w_j c_{kj} = 1 \end{array}$$

For each player i , including k :

$$\sum_j w_j c_{ij} \geq z.$$

For every weight j :

$$w_j \geq e.$$

Example

The GBS Construction Materials Company provides steel structural materials to industrial contractors. GBS recently did a survey of price, delivery performance, and quality in order to get an assessment of how it compares with its four major competitors. The results of the survey, with the names of all companies disguised, appears in the following table:

Company	Quality (based on freedom from scale, straightness, etc., based on mean rank, where 1.0 is best)	Delivery time (days)	Price (in \$/cwt)
A	1.8	14	\$21
B	4.1	1	\$26
C	3.2	3	\$25
D	1.2	5	\$23
E	2.4	7	\$22

For each of the three criteria, smaller is always better. Vendors A , B , and D are clearly competitive, based on price, delivery time, and quality, respectively. For example, a customer for whom quality is paramount will choose D . A customer for whom delivery time is important will choose B . Are C and E competitive? Imagine a customer who uses a linear weighting system to identify the best bid (e.g., score = $WQ \times \text{Quality} + WT \times (\text{delivery time}) + WP \times \text{price}$). Is there a set of weights (all nonnegative), so $\text{Score}(C) < \text{Score}(i)$, for $i = A, B, D, E$? Likewise, for E ?

The model for Company C is:

```

MODEL:
MAX = Z;
[A] - Z + 1.8*WQ + 14*WT + 21*WP ≥ 0;
[B] - Z + 4.1*WQ +   WT + 26*WP ≥ 0;
[C] - Z + 3.2*WQ +  3*WT + 25*WP ≥ 0;
[D] - Z + 1.2*WQ +  5*WT + 23*WP ≥ 0;
[E] - Z + 2.4*WQ +  7*WT + 22*WP ≥ 0;
[CTARG]      3.2*WQ +  3*WT + 25*WP = 1;
[QUAL]   WQ ≥  0.0005;
[TIME]   WT ≥  0.0005;
[PRICE]  WP ≥  0.0005;
END

```

The solution is:

```

Optimal solution found at step:      4
Objective value:                    0.9814257

```

Variable	Value	Reduced Cost
Z	0.9814257	0.0000000
WQ	0.5000000E-03	0.0000000
WT	0.2781147E-01	0.0000000
WP	0.3659862E-01	0.0000000

Row	Slack or Surplus	Dual Price
1	0.9814257	1.0000000
A	0.1774060	0.0000000
B	0.0000000	-0.5137615
C	0.1857431E-01	0.0000000
D	0.0000000	-0.4862385
E	0.1962431E-01	0.0000000
CTARG	0.0000000	0.9816514
QUAL	0.0000000	-0.4513761
TIME	0.2731147E-01	0.0000000
PRICE	0.3609862E-01	0.0000000

Company C has an efficiency rating of 0.981. Thus, it is not on the efficient frontier. With a similar model, you can show Company E is on the efficient frontier.

14.5.3 Efficient Points, the Mixed Case

In many situations, there may be some dimensions where less is better, such as risk; whereas, there are other dimensions where more is better, such as chocolate.

In this case, unless we make additional restrictions on the weights, we cannot get a simple score of efficiency between 0 and 1 for a company. We can nevertheless extend the previous approach to determine if a point is on the efficient frontier.

Define:

c_{ij} = level of the j^{th} "less is better" attribute for player i ,
 r_{ij} = level of the j^{th} "more is better" attribute for player i ,
 w_j = weight to be applied to the j^{th} "less is better" attribute,
 v_j = weight to be applied to the j^{th} "more is better" attribute.

In words, to evaluate the efficiency of player or point k , we want to:

$$\begin{aligned} & \text{Max score } (k) - (\text{best score of any other player}) \\ & \text{subject to} \\ & \text{sum of the weights} = 1 \end{aligned}$$

If the objective value is nonnegative, then player k is efficient; whereas, if the objective is negative, then there is no set of weights such that player k scores at least as well as every other player.

If we denote the best score of any other player by z , then, more specifically, we want to solve:

$$\begin{aligned} & \text{Max } \sum_j v_j r_{kj} - \sum_j w_j c_{kj} - z \\ & \text{subject to} \\ & \text{For each player } i, i \neq k \\ & z \geq \sum_j v_j r_{ij} - \sum_j w_j c_{kj} \\ & \text{and} \\ & \sum_j v_j + \sum_j w_j = 1, \end{aligned}$$

$v_j \geq e$, $w_j \geq e$, z unconstrained in sign, where e is a small positive number as introduced in the “more-is-better” case.

The dual of this problem is to find a set of nonnegative weights, λ_i , to apply to each of the other players to:

$$\begin{aligned} & \text{Minimize } g \\ & \text{subject to} \\ & \sum_i \lambda_i = 1 \\ & \text{For each “more is better” attribute } j: \\ & g + \sum_{i \neq k} \lambda_j r_{ij} \geq r_{kj}, \\ & \text{For each “less is better” attribute } j: \\ & g - \sum_{i \neq k} \lambda_j c_{ij} \geq -c_{kj}, \\ & g \text{ unconstrained in sign.} \end{aligned}$$

If g is nonnegative, it means no weighted combination of other points (or players) could be found, so their weighted performance surpasses k on every dimension.

14.6 Comparing Performance with Data Envelopment Analysis

Data Envelopment Analysis (DEA) is a method for identifying efficient points in the mixed case. That is, when there are both “less is better” and “more is better” measures. An attractive feature of DEA, relative to the previous method discussed, is it does produce an efficiency score between 0 and 1. It does this by making slightly stronger assumptions about how efficiency is measured. Specifically, DEA assumes each performance measure can be classified as either an input or an output. For outputs, more is better; whereas, for inputs, less is better. The “score” of a point or a decision-making unit is then the ratio of an output score divided by an input score.

DEA was originated by Charnes, Cooper, and Rhodes (1978) as a means of evaluating the performance of decision-making units. Examples of decision-making units might be hospitals, banks, airports, schools, and managers. For example, Bessent, Bessent, Kennington, and Reagan (1982) used the approach to evaluate the performance of 167 schools around Houston, Texas. Simple comparisons can be misleading because different units are probably operating in different environments. For example, a school operating in a wealthy neighborhood will probably have higher test scores than a

school in a poor neighborhood, even though the teachers in the poor school are working harder and require more skill than the teachers in the wealthy school. Also, different decision makers may have different skills. If the teachers in school (A) are well trained in science and those in school (B) are well trained in fine arts, then a scoring system that applies a lot of weight to science may make the teachers in (B) appear to be inferior, even though they are doing an outstanding job at what they do best.

DEA circumvents both difficulties in a clever fashion. If the arts teachers were choosing the performance measures, they would choose one that placed a lot of weight on arts. However, the science teachers would probably choose a different one. DEA follows the philosophy of a popular fast food chain, that is, "Have it your way." DEA will derive an "efficiency" score between 0 and 1 for each unit by solving the following problem:

For each unit k :
 Choose a scoring function
 so as to:
 maximize score of unit k
 subject to:
 For every unit j (including k):
 score $_j \leq 1$.

Thus, unit k may choose a scoring function making it look as good as possible, so long as no other unit gets a score greater than 1 when that same scoring function is applied to the other unit. If a unit k gets a score of 1.0, it means there is no other unit strictly dominating k .

In the version of DEA we consider, the allowed scoring functions are limited to ratios of weighted outputs to weighted inputs. For example:

$$\text{score} = \frac{\text{weighted sum of outputs}}{\text{weighted sum of inputs}}$$

We can normalize weights, so:

$$\text{weighted sum of inputs} = 1;$$

then "score ≤ 1 " is equivalent to:

$$\text{weighted sum of outputs} \leq \text{weighted sum of inputs}.$$

Algebraically, the DEA model is:

Given

n = decision-making units,

m = number of inputs,

s = number of outputs.

Observed data:

c_{ij} = level of j^{th} input for unit i ,

r_{ij} = level of j^{th} output for unit i .

Variables:

w_j = weight applied to the j^{th} input,

v_j = weight (or value) applied to the j^{th} output.

For unit k , the model to compute the best score is:

$$\begin{aligned} & \text{Maximize } \sum_{j=1}^s v_j r_{kj} \\ & \text{subject to} \\ & \sum_{j=1}^m w_j c_{kj} = 1 \end{aligned}$$

For each unit i (including k):

$$\sum_{j=1}^s v_j r_{ij} \leq \sum_{j=1}^m w_j c_{ij}$$

This model will tend to have more constraints than decision variables. Thus, if implementation efficiency is a major concern, one may wish to solve the dual of this model rather than the primal.

Sexton et al. (1994) describes the use of DEA to analyze the transportation efficiency of 100 county level school districts in North Carolina. Examples of inputs were number of buses used and expenses. The single output was the number of pupils transported per day. Various adjustments were made in the analysis to take into account the type of district (e.g., population density). A savings of about \$50 million over a four-year period was claimed.

Sherman and Ladino (1995) describe the use of DEA to analyze and improve the efficiency of branches in a 33-unit branch banking system. They claimed annual savings of \$6 million. Examples of inputs for a branch unit were: number of tellers, office square feet, and expenses excluding personnel. Examples of outputs were number of deposits, withdrawals, checks cashed, loans made, and new accounts. Of the 33 units, ten obtained an efficiency score of 100%. An automatic result of the DEA analysis for an inefficient unit is an identification of the one or two units that dominate the inefficient unit. This dominating unit was then used as a “benchmark or best practices case” to help identify how the inefficient unit could be improved.

Example

Below are four performance measures on six high schools: Bloom (*BL*), Homewood (*HW*), New Trier (*NT*), Oak Park (*OP*), York (*YK*), and Elgin (*EL*). Cost/pupil is the number of dollars spent per year per pupil by the school. Percent not-low-income is the fraction of the student body coming from homes not classified as low income. The writing and science scores are the averages over students in a school on a standard writing test and a standard science test. The first two measures are treated as inputs, over which teachers and administrators have no control. The test scores are treated as outputs.

School	Cost/pupil	Percent not low income	Writing score	Science score
BL	8939	64.3	25.2	223
HW	8625	99	28.2	287
NT	10813	99.6	29.4	317
OP	10638	96	26.4	291
YK	6240	96.2	27.2	295
EL	4719	79.9	25.5	222

Which schools would you consider “efficient”? New Trier has the highest score in both writing (29.4) and science (317). However, it also spends the most per pupil, \$10,813, and has the highest fraction not-low-income. A DEA model for maximizing the score of New Trier appears below. Notice we have scaled each factor, so it lies in the range (1,1000). This is important if one requires a strictly positive minimum weight on each factor, as the last four constraints of the model imply. The motivation for the strictly positive weight on each factor was given in the description of the “more-is-better” case:

```

MODEL:
MAX = SCORENT;
! Define the numerator for New Trier;
[DEFNUMNT] SCORENT - 317*WNTSCIN - 29.4*WNTWRIT = 0;
! Fix the denominator for New Trier;
[FIXDNMNT] 99.6*WNTRICH + 108.13*WNTCOST = 1;
! Numerator/ Denominator < 1 for every school,;
! or equivalently, Numerator < Denominator;
[BLNT] 223*WNTSCIN+25.2*WNTWRIT-64.3*WNTRICH-89.39*WNTCOST<=0;
[HWNT] 287*WNTSCIN+28.2*WNTWRIT-99*WNTRICH-86.25*WNTCOST <= 0;
[NTNT] 317*WNTSCIN+29.4*WNTWRIT-99.6*WNTRICH-108.13*WNTCOST<=0;
[OPNT] 291*WNTSCIN+26.4*WNTWRIT-96*WNTRICH-106.38*WNTCOST<=0;
[YKNT] 295*WNTSCIN+27.2*WNTWRIT-96.2*WNTRICH-62.40*WNTCOST<=0;
[ELNT] 222*WNTSCIN+25.5*WNTWRIT-79.9*WNTRICH-47.19*WNTCOST<=0;
! Each measure must receive a little weight;
[SCINT] WNTSCIN >= 0.0005;
[WRINT] WNTWRIT >= 0.0005;
[RICNT] WNTRICH >= 0.0005;
[COSNT] WNTCOST >= 0.0005;
END

```

The solution is:

```

Optimal solution found at step:          3
Objective value:          0.9615803

```

Variable	Value	Reduced Cost
SCORENT	0.9615803	0.0000000
WNTSCIN	0.2987004E-02	0.0000000
WNTWRIT	0.5000000E-03	0.0000000
WNTRICH	0.8204092E-02	0.0000000
WNTCOST	0.1691228E-02	0.0000000

Row	Slack or Surplus	Dual Price
1	0.9615803	1.0000000
DEFNUMNT	0.0000000	1.0000000
FIXDNMNT	0.0000000	0.9635345
BLNT	0.0000000	0.8795257
HWNT	0.8670327E-01	0.0000000
NTNT	0.3841965E-01	0.0000000
OPNT	0.8508738E-01	0.0000000
YKNT	0.0000000	0.4097145
ELNT	0.5945104E-01	0.0000000
SCINT	0.2487004E-02	0.0000000
WRINT	0.0000000	-3.908281
RICNT	0.7704092E-02	0.0000000
COSNT	0.1191227E-02	0.0000000

The score of New Trier is less than 1.0. Thus, according to DEA, New Trier is not efficient. Looking at the solution report, one can deduce that *NT* is, according to DEA, strictly less efficient than *BL* and *YK*. Notice their “score less-than-or-equal-to 1” constraints are binding. Thus, if *NT* wants to improve its efficiency by doing a benchmark study, it should perhaps study the practices of *BL* and *YK* for insight.

A sets-based model that evaluates all the schools in one model is given below:

```

MODEL:
! Data Envelopment Analysis of Decision Maker Efficiency ;
SETS:
  DMU:      !The decisionmaking units;
           SCORE;! Each decision making unit has a
                score to be computed;

  FACTOR;
! There is a set of factors, input & output;
DXF( DMU, FACTOR):  F, ! F( I, J) = Jth factor of DMU I;
                   W;  ! Weights used to compute DMU I's score;
ENDSETS
DATA:
  DMU = BL HW NT OP YK EL;
! Inputs are spending/pupil, % not low income;
! Outputs are Writing score and Science score;
  NINPUTS = 2;  ! The first NINPUTS factors are inputs;
  FACTOR= COST RICH      WRIT SCIN;
!       The inputs,      the outputs;
  F =   89.39  64.3      25.2  223
        86.25  99        28.2  287
        108.13 99.6      29.4  317
        106.38 96        26.4  291
        62.40 96.2      27.2  295
        47.19 79.9      25.5  222;
  WGTMIN = .0005;  ! Min weight applied to every factor;
  BIGM = 999999;  ! Biggest a weight can be;
ENDDATA
!-----;
! The Model;
! Try to make everyone's score as high as possible;
  MAX = @SUM( DMU: SCORE);
! The LP for each DMU to get its score;
  @FOR( DMU( I):
    [CSCR] SCORE( I) = @SUM( FACTOR(J)|J #GT# NINPUTS:
                          F( I, J)* W( I, J));
! Sum of inputs(denominator) = 1;
    [SUM21] @SUM( FACTOR( J)| J #LE# NINPUTS:
              F( I, J)* W( I, J)) = 1;
! Using DMU I's weights, no DMU can score better than 1,
  Note Numer/Denom <= 1 implies Numer <= Denom;
    @FOR( DMU( K):
      [LE1] @SUM( FACTOR( J)| J #GT# NINPUTS: F( K, J) * W( I, J))
            <= @SUM( FACTOR( J)| J #LE# NINPUTS: F( K, J) * W( I, J))
            )
    );
! The weights must be greater than zero;

```

```

    @FOR( DXF( I, J): @BND( WGTMIN, W, BIGM));
END

```

Part of the output is:

Variable	Value	Reduced Cost
SCORE(BL)	1.000000	0.0000000
SCORE(HW)	0.9095071	0.0000000
SCORE(NT)	0.9615803	0.0000000
SCORE(OP)	0.9121280	0.0000000
SCORE(YK)	1.000000	0.0000000
SCORE(EL)	1.000000	0.0000000

We see that the only efficient schools are Bloom, Yorktown, and Elgin.

14.7 Problems

- In the example staffing problem in this chapter, the primary criterion was minimizing the number of people hired. The secondary criterion was to spread out any excess capacity as much as possible. The primary criterion received a weight of 9; whereas, the secondary criterion received a weight of 1. The minimum number of people required (primary criterion) was 8. How much could the weight on the secondary criterion be increased before the number of people hired increases to more than 8?
- Reconsider the advertising media selection problem of this chapter.
 - Reformulate it, so we achieve at least 197 (in 1000's) useful exposures at minimum cost.
 - Predict the cost before looking at the solution.
- A description of a "project crashing" decision appears in Chapter 8. There were two criteria, project length and project cost. Trace out the efficient frontier describing the trade-off between length and cost.
- The various capacities of several popular sport utility vehicles, as reported by a popular consumer rating magazine, are listed below:

Vehicle	Seats	Cargo Floor Length (in.)	Rear Opening Height (in.)	Cargo Volume (cubic ft)
Blazer	6	75.5	31.5	42.5
Cherokee	5	62.0	33.5	34.5
Land Rover	7	49.5	42.0	42.0
Land Cruiser	8	65.5	38.5	44.5
Explorer	6	78.5	35.0	48.0
Trooper	5	57.0	36.5	42.5

Assuming sport utility vehicle buyers sport a linear utility and more capacity is better, which of the above vehicles are on the efficient frontier according to these four capacity measures?

5. The Rotorua Fruit Company sells various kinds of premium fruits (e.g., apples, peaches, and kiwi fruit) in small boxes. Each box contains a single kind of fruit. The outside of the box specifies:
- i) the kind of fruit,
 - ii) the number of pieces of fruit, and
 - iii) the approximate weight of the fruit in the box.

Satisfying specification (iii) is nontrivial, because the per unit weight of fruit as it comes from the orchard is a random variable. Consider the case of apples. Each apple box contains 12 apples. The label on each apple box says the box contains 4.25 lbs. of apples. In fact, a typical apple weighs from 5 to 6.5 ounces. At 16 ounces/lb., a box of 5-ounce apples would weigh only 3.75 lbs., whereas, a box of 6.5-ounce apples would weigh 4.875 lbs. The approach Rotorua is considering is to have a set of 24 automated scales on the box loading line. The 24 scales will be loaded with 24 apples. Based on the weights of the apples, a set of 12 apples whose total weight comes close to 4.25 lbs., will be dropped into the current empty box. In the next cycle, the 12 empty scales will be reloaded with new apples, a new empty box will be moved into position, and the process repeated. Rotorua cannot always achieve the ideal of exactly 4.25 lbs. in a box. However, being underweight is worse than being overweight. Rotorua has characterized its feeling/utility for this under/over issue by stating that given the choice between loading a box one ounce under and one ounce over, it clearly prefers to load it one ounce over. However, it would be indifferent between loading a box one ounce under vs. five ounces over.

Suppose the scales currently contain apples with the following weights in ounces:

5.6, 5.9, 6.0, 5.8, 5.9, 5.4, 5.0, 5.5, 6.3, 6.2, 5.1, 6.2,
6.1, 5.2, 6.4, 5.7, 5.6, 5.5, 5.3, 6.0, 5.4, 5.3, 5.8, 6.1.

- a) How would you load the next box?
- b) Discuss some of the issues in implementing your approach.

Economic Equilibria and Pricing

Plus ce change, plus ce la meme chose.

-Alphonse Karr: "Les Guepes", 1849

15.1 What is an Equilibrium?

As East and West Germany were about to be re-united in the early 1990's, there was considerable interest in how various industries in the two regions would fare under the new economic structure. Similar concerns existed about the same time in Canada, the United States, and Mexico, as trade barriers were about to be dropped under the structure of the new North American Free Trade Agreement (NAFTA). Some of the planners concerned with NAFTA used so-called economic equilibrium models to predict the effect of the new structure on various industries. The basic idea of an equilibrium model is to predict what the state of a system will be in the "steady state", under a new set of external conditions. These new conditions are typically things like new tax laws, new trading conditions, or dramatically new technology for producing some product.

Equilibrium models are of interest to at least two kinds of decision makers: people who set taxes, and people who are concerned with appropriate prices to set. Suppose state X feels it would like to put a tax on littering with, say, glass bottles. An explicit tax on littering is difficult to enforce. Alternatively, the state X might feel it could achieve the same effect by putting a tax on bottles when purchased, and then refunding the tax when the bottle is returned for recycling. Both of these are easy to implement and enforce. If a neighboring state, Y , however, does not have a bottle refund, then citizens of the state Y will be motivated to cross the border to X and turn their bottles in for refund. If the refund is high, then the refund from state X may end up subsidizing bottle manufacturing in state Y . Is this the intention of state X ? A comprehensive equilibrium model takes into account all the incentives of the various sectors or players.

If one is modeling an economy composed of two or more individuals, each acting in his or her self-interest, there is no obvious overall objective function that should be maximized. In a market, a solution, or equilibrium point, is a set of prices such that supply equals demand for each commodity. More generally, an equilibrium for a system is a state in which no individual or component in the system is motivated to change the state. Thus, at equilibrium in an economy, there are no arbitrage possibilities (e.g., buy a commodity in one market and sell it in another market at a higher price at no

risk). Because economic equilibrium problems usually involve multiple players, each with their own objective, these problems can also be viewed as multiple criteria problems.

15.2 A Simple Simultaneous Price/Production Decision

A firm that has the choice of setting either price or quantity for its products may wish to set them simultaneously. If the production process can be modeled as a linear program and the demand curves are linear, then the problem of simultaneously setting price and production follows.

A firm produces and sells two products A and B at price P_A and P_B and in quantities X_A and X_B . Profit maximizing values for P_A , P_B , X_A , and X_B are to be determined. The quantities (sold) are related to the prices by the demand curves:

$$\begin{aligned} X_A &= 60 - 21 P_A + 0.1 P_B, \\ X_B &= 50 - 25 P_B + 0.1 P_A. \end{aligned}$$

Notice the two products are mild substitutes. As the price of one is raised, it causes a modest increase in the demand for the other item.

The production side has the following features:

	Product	
	A	B
Variable Cost per Unit	\$0.20	\$0.30
Production Capacity	25	30

Further, the total production is limited by the constraint:

$$X_A + 2X_B \leq 50.$$

The problem can be written in LINGO form as:

```
MIN = -(PA - 0.20) * XA - (PB - 0.30) * XB;
XA + 21 * PA - 0.1 * PB = 60;
! Demand curve definition;
XB + 25 * PB - 0.1 * PA = 50;
XA <= 25;          !Supply restrictions;
XB <= 30;
XA + 2 * XB <= 50;
```

The solution is:

Optimal solution found at step:		4
Objective value:		-51.95106
Variable	Value	Reduced Cost
PA	1.702805	0.0000000
XA	24.39056	0.0000000
PB	1.494622	0.0000000
XB	12.80472	0.0000000
Row	Slack or Surplus	Dual Price
1	-51.95106	1.0000000
2	0.0000000	1.163916
3	0.0000000	0.5168446
4	0.6094447	0.2531134E-07
5	17.19528	0.0000000
6	0.0000000	0.3388889

Note it is the joint capacity constraint $X_A + 2X_B \leq 50$, which is binding. The total profit contribution is \$51.951058.

15.3 Representing Supply & Demand Curves in LPs

The use of smooth supply and demand curves has long been a convenient device in economics courses for thinking about how markets operate. In practice, it may be more convenient to think of supply and demand in more discrete terms. What is frequently done in practice is to use a sector approach for representing demand and supply behavior. For example, one represents the demand side as consisting of a large number of sectors with each sector having a fairly simple behavior. The most convenient behavior is to think of each demand sector as being represented by two numbers:

the maximum price (its reservation price) the sector is willing to pay for a good, and
the amount the sector will buy if the price is not above its reservation price.

The U.S. Treasury Department, when examining the impact of proposed taxes, has apparently represented taxpayers by approximately 10,000 sectors, see Glover and Klingman (1977) for example.

The methodology about to be described is similar to that used in the PIES (Project Independence Evaluation System) model developed by the Department of Energy. This model and its later versions were extensively used from 1974 onward to evaluate the effect of various U.S. energy policies.

Consider the following example. There is a producer A and a consumer X who have the following supply and demand schedules for a single commodity (e.g., energy):

Producer A		Consumer X	
Market Price per Unit	Amount Willing To Sell	Market Price per Unit	Amount Willing To Buy
\$1	2	\$9	2
2	4	4.5	4
3	6	3	6
4	8	2.25	8

For example, if the price is less than \$2, but greater than \$1, then the producer will produce 2 units. However, the consumer would like to buy at least 8 units at this price. By inspection, note the equilibrium price is \$3 and any quantity.

It is easy to find an equilibrium in this market by inspection. Nevertheless, it is useful to examine the LP formulation that could be used to find it. Although there is a single market clearing price, it is useful to interpret the supply schedule as if the supplier is willing to sell the first 2 units at \$1, the next 2 units at \$2 each, etc. Similarly, the consumer is willing to pay \$9 each for the first 2 units, \$4.5 for the next 2 units, etc. To find the market-clearing price such that the amount produced equals the amount consumed, we act as if there is a broker who actually buys and sells at these marginal prices, and all transactions must go through the broker. The broker maximizes his profits. The broker will continue to increase the quantity of goods transferred as long as he can sell it at a price higher than his purchase price. At the broker's optimum, the quantity bought equals the quantity sold and the price offered by the buyers equals the price demanded by the sellers. This satisfies the conditions for a market equilibrium.

Graphically, the situation is as in Figure 15.1:

Figure 15.1 Demand and Supply Curves

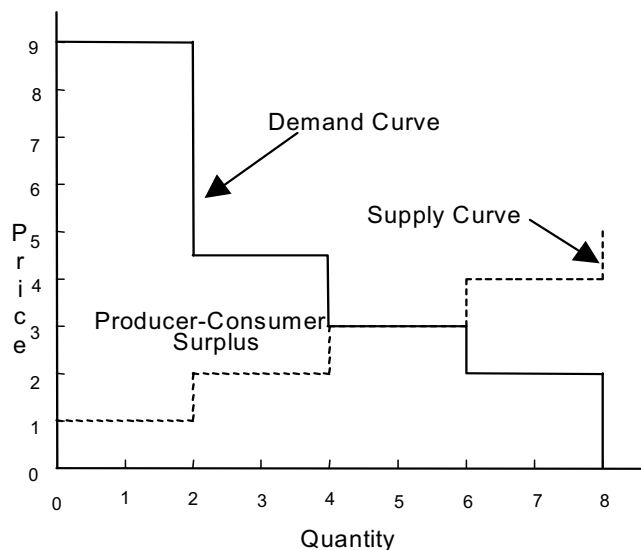

The area marked “producer-consumer surplus” is the profit obtained by the hypothetical broker. In reality, this profit is allocated between the producer and the consumer according to the equilibrium price. In the case where the equilibrium price is \$3, the consumer’s profit or surplus is the portion of the producer-consumer surplus area above the \$3 horizontal line, while the producer’s profit or surplus is the portion of the producer-consumer surplus area below \$3.

Readers with a mathematical bent may note the general approach we are using is based on the fact that, for many problems of finding an equilibrium, one can formulate an objective function that, when optimized, produces a solution satisfying the equilibrium conditions.

For purposes of the LP formulation, define:

$A1$ = units sold by producer for \$1 per unit;
 $A2$ = units sold by producer for \$2 per unit;
 $A3$ = units sold by producer for \$3 per unit;
 $A4$ = units sold by producer for \$4 per unit;
 $X1$ = units bought by consumer for \$9 per unit;
 $X2$ = units bought by consumer for \$4.5 per unit;
 $X3$ = units bought by consumer for \$3 per unit;
 $X4$ = units bought by consumer for \$2.25 per unit.

The formulation is:

```

MAX = 9 * X1 + 4.5 * X2 + 3 * X3 + 2.25 * X4
! Maximize broker's revenue;
- A1 - 2 * A2 - 3 * A3 - 4 * A4;
! minus cost;
A1 + A2 + A3 + A4 - X1 - X2 - X3 - X4 = 0;
! Supply = demand;
A1 <= 2;
A2 <= 2;
A3 <= 2;
A4 <= 2;
! Steps in supply;
X1 <= 2;
X2 <= 2;
X3 <= 2;
X4 <= 2;
! and demand functions;
  
```

A solution is:

$A1 = A2 = A3 = X1 = X2 = X3 = 2$
 $A4 = X4 = 0$

Note there is more than one solution, since $A3$ and $X3$ cancel each other when they are equal.

The dual price on the first constraint is \$3. In general, the dual price on the constraint that sets supply equal to demand is the market-clearing price.

Let us complicate the problem by introducing another supplier, B , and another consumer, Y . Their supply and demand curves are, respectively:

Producer B		Consumer Y	
Market Price per Unit	Amount Willing To Sell	Market Price per Unit	Amount Willing To Buy
\$2	2	\$15	2
4	4	8	4
6	6	5	6
8	8	3	8

An additional complication is shipping costs \$1.5 per unit shipped from A to Y , and \$2 per unit shipped from B to X . What will be the clearing price at the shipping door of A , B , X , and Y ? How much will each participant sell or buy?

The corresponding LP can be developed if we define $B1, B2, B3, B4, Y1, Y2, Y3$ and $Y4$ analogous to $A1, X1$, etc. Also, we define AX, AY, BX , and BY as the number of units shipped from A to X , A to Y , B to X , and B to Y , respectively. The formulation is:

```

MAX = 9 * X1 + 4.5 * X2 + 3 * X3 + 2.25 * X4
      + 15 * Y1 + 8 * Y2 + 5 * Y3 + 3 * Y4
      - 2 * BX - 1.5 * AY - A1 - 2 * A2 - 3 * A3
      - 4 * A4 - 2 * B1 - 4 * B2 - 6 * B3 - 8 * B4;
! Maximize revenue - cost for broker;
- AY + A1 + A2 + A3 + A4 - AX = 0;
! amount shipped from A;
- BX + B1 + B2 + B3 + B4 - BY = 0;
! amount shipped from B;
- X1 - X2 - X3 - X4 + BX + AX = 0;
! amount shipped from X;
- Y1 - Y2 - Y3 - Y4 + AY + BY = 0;
! amount shipped from Y;
A1 <= 2;
A2 <= 2;
A3 <= 2;
A4 <= 2;
B1 <= 2;
B2 <= 2;
B3 <= 2;
B4 <= 2;
X1 <= 2;
X2 <= 2;
X3 <= 2;
X4 <= 2;
Y1 <= 2;
Y2 <= 2;
Y3 <= 2;
Y4 <= 2;

```

Notice from the objective function that the broker is charged \$2 per unit shipped from B to X and \$1.5 per unit shipped from A to Y . Most of the constraints are simple upper bound (SUB) constraints. In realistic-size problems, several thousand SUB-type constraints can be tolerated without adversely affecting computational difficulty.

The original solution is:

Optimal solution found at step:		3
Objective value:		21.00000
Variable	Value	Reduced Cost
X1	2.000000	0.000000
X2	2.000000	0.000000
X3	2.000000	0.000000
X4	0.000000	0.750000
A1	2.000000	0.000000
A2	2.000000	0.000000
A3	2.000000	0.000000
A4	0.000000	1.000000
Row	Slack or Surplus	Dual Price
1	21.00000	1.000000
2	0.000000	-3.000000
3	0.000000	2.000000
4	0.000000	1.000000
5	0.000000	0.000000
6	2.000000	0.000000
7	0.000000	6.000000
8	0.000000	1.500000
9	0.000000	0.000000
10	2.000000	0.000000

From the dual prices on rows 2 through 5, we note the prices at the shipping door of A , B , X , and Y are \$3.5, \$5, \$3.5, and \$5, respectively. At these prices, A and B are willing to produce 6 and 4 units, respectively. While, X and Y are willing to buy 4 and 6 units, respectively. A ships 2 units to Y , where the \$1.5 shipping charge causes them to sell for \$5 per unit. A ships 4 units to X , where they sell for \$3.5 per unit. B ships 4 units to Y , where they sell for \$5 per unit.

15.4 Auctions as Economic Equilibria

The concept of a broker who maximizes producer-consumer surplus can also be applied to auctions. LP is useful if features that might be interpreted as bidders with demand curves complicate the auction. The example presented here is based on a design by R. L. Graves for a course registration system used since 1981 at the University of Chicago in which students bid on courses. See Graves, Sankaran, and Schrage (1993).

Suppose there are N types of objects to be sold (e.g., courses) and there are M bidders (e.g., students). Bidder i is willing to pay up to b_{ij} , $b_{ij} \geq 0$ for one unit of object type j . Further, a bidder is interested in at most one unit of each object type. Let S_j be the number of units of object type j available for sale.

There is a variety of ways of holding the auction. Let us suppose it is a sealed-bid auction and we want to find a single, market-clearing price, p_j , for each object type j , such that:

- at most, S_j units of object j are sold;
- any bid for j less than p_j does not buy a unit;
- $p_j = 0$ if less than S_j units of j are sold;
- any bid for j greater than p_j does buy a unit.

It is easy to determine the equilibrium p_j 's by simply sorting the bids and allocating each unit to the higher bidder first. Nevertheless, in order to prepare for more complicated auctions, let us consider

how to solve this problem as an optimization problem. Again, we take the view of a broker who sells at as high a price as possible (buys at as low) and maximizes profits.

Define:

$$x_{ij} = 1 \text{ if bidder } i \text{ buys a unit of object } j, \text{ else } 0.$$

The LP is:

$$\begin{aligned} \text{Maximize} \quad & \sum_{i=1}^M \sum_{j=1}^N x_{ij} b_{ij} \\ \text{subject to} \quad & \sum_{i=1}^M x_{ij} \leq S_j \text{ for } j = 1 \text{ to } N \\ & x_{ij} \leq 1 \text{ for all } i \text{ and } j. \end{aligned}$$

The dual prices on the first N constraints can be used, with minor modification, as the clearing prices p_j . The possible modifications have to do with the fact that, with step function demand and/or supply curves, there is usually a small range of acceptable clearing prices. The LP solution will choose one price in this range, usually at one end of the range. One may wish to choose a price within the interior of the range to break ties.

Now, we complicate this auction slightly by adding the condition that no bidder wants to buy more than 3 units total. Consider the following specific situation:

		Maximum Price Willing To Pay				
		Objects				
		1	2	3	4	5
Bidders	1	9	2	8	6	3
	2	6	7	9	1	5
	3	7	8	6	3	4
	4	5	4	3	2	1
Capacity		1	2	3	3	4

For example, bidder 3 is willing to pay up to 4 for one unit of object 5. There are only 3 units of object 4 available for sale.

We want to find a “market clearing” price for each object and an allocation of units to bidders, so each bidder is willing to accept the units awarded to him at the market-clearing price. We must generalize the previous condition d to d' : a bidder is satisfied with a particular unit if he cannot find another unit with a bigger difference between his maximum offer price and the market clearing price. This is equivalent to saying each bidder maximizes his consumer surplus.

The associated LP is:

```

MAX = 9 * X11 + 2 * X12 + 8 * X13 + 6 * X14
      + 3 * X15 + 6 * X21 + 7 * X22 + 9 * X23
      + X24 + 5 * X25 + 7 * X31 + 8 * X32 + 6 * X33
      + 3 * X34 + 4 * X35 + 5 * X41 + 4 * X42
      + 3 * X43 + 2 * X44 + X45;
      !(Maximize broker revenues);
X11 + X21 + X31 + X41 <= 1;
      !(Units of object 1 available);
X12 + X22 + X32 + X42 <= 2;          !           .;
X13 + X23 + X33 + X43 <= 3;          !           .;
X14 + X24 + X34 + X44 <= 3;          !           .;
X15 + X25 + X35 + X45 <= 4;
      !(Units of object 5 available);
X11 + X12 + X13 + X14 + X15 <= 3;
      !(Upper limit on buyer 1 demand);
X21 + X22 + X23 + X24 + X25 <= 3;    !           .;
X31 + X32 + X33 + X34 + X35 <= 3;    !           .;
X41 + X42 + X43 + X44 + X45 <= 3;
      !(Upper limit on buyer 2 demand);
X11 <= 1;
X21 <= 1;
X31 <= 1;
X41 <= 1;
X12 <= 1;
X22 <= 1;
X32 <= 1;
X42 <= 1;
X13 <= 1;
X23 <= 1;
X33 <= 1;
X43 <= 1;
X14 <= 1;
X24 <= 1;
X34 <= 1;
X15 <= 1;
X25 <= 1;
X35 <= 1;
X45 <= 1;

```

The solution is:

```

Optimal solution found at step:      23
Objective value:                      67.00000
Variable      Value      Reduced Cost
X11           1.000000      0.0000000
X12           0.000000      4.0000000
X13           1.000000      0.0000000
X14           1.000000      0.0000000
X15           0.000000      0.0000000
X21           0.000000      0.0000000
X22           1.000000      0.0000000
X23           1.000000      0.0000000

```

X24	0.0000000	0.0000000
X25	1.0000000	0.0000000
X31	0.0000000	3.0000000
X32	1.0000000	0.0000000
X33	1.0000000	0.0000000
X34	0.0000000	2.0000000
X35	1.0000000	0.0000000
X41	0.0000000	2.0000000
X42	0.0000000	0.0000000
X43	0.0000000	0.0000000
X44	2.0000000	0.0000000
X45	1.0000000	0.0000000
Row	Slack or Surplus	Dual Price
1	67.000000	1.000000
2	0.0000000	6.000000
3	0.0000000	3.000000
4	0.0000000	2.000000
5	0.0000000	1.000000
6	1.0000000	0.0000000
7	0.0000000	3.000000
8	0.0000000	0.0000000
9	0.0000000	4.000000
10	0.0000000	1.000000
11	0.0000000	0.0000000
12	1.0000000	0.0000000
13	1.0000000	0.0000000
14	1.0000000	0.0000000
15	1.0000000	0.0000000
16	0.0000000	4.000000
17	0.0000000	1.000000
18	1.0000000	0.0000000
19	0.0000000	3.000000
20	0.0000000	7.000000
21	0.0000000	0.0000000
22	1.0000000	0.0000000
23	0.0000000	2.000000
24	1.0000000	0.0000000
25	1.0000000	0.0000000
26	1.0000000	0.0000000
27	0.0000000	5.000000
28	0.0000000	0.0000000
29	0.0000000	0.0000000

The dual prices on the first five constraints essentially provide us with the needed market clearing prices. To avoid ties, we may wish to add or subtract a small number to each of these prices. We claim that acceptable market clearing prices for objects 1, 2, 3, 4 and 5 are 5, 5, 3, 0, and 0, respectively.

Now note that, at these prices, the market clears. Bidder 1 is awarded the sole unit of object 1 at a price of \$5.00. If the price were lower, bidder 4 could claim the unit. If the price were more than 6, then bidder 1's surplus on object 1 would be less than $9 - 6 = 3$. Therefore, he would prefer object 5 instead. Where his surplus is $3 - 0 = 3$. If object 2's price were less than 4, then bidder 4 could claim the unit. If the price were greater than 5, then bidder 3 would prefer to give up his type-2 unit (with

surplus $8 - 5 = 3$) and take a type-4 unit, which has a surplus of $3 - 0 = 3$. Similar arguments apply to objects 3, 4, and 5.

15.5 Multi-Product Pricing Problems

When a vendor sets prices, they should take into account the fact that a buyer will tend to purchase a product or, more generally, a bundle of products that gives the buyer the best deal. In economics terminology, the vendor should assume buyers will maximize their utility. A reasonable way of representing buyer behavior is to make the following assumptions:

1. Prospective buyers can be partitioned into market segments (e.g., college students, retired people, etc.). Segments can be defined sufficiently small, so individuals in the same segment have the same preferences.
2. Each buyer has a reservation price for each possible combination (or bundle) of products he or she might buy.
3. Each buyer will purchase that single bundle for which his reservation price minus his cost is maximized.

A smart vendor will set prices to maximize his profits, subject to customers maximizing their utility as described in (1-3).

The following is a general model that allows a number of features:

- a) some segments (e.g., students) may get a discount from the list price;
- b) there may be a customer segment specific cost of selling a product (e.g., because of a tax or intermediate dealer commission);
- c) the vendor incurs a fixed cost if he wishes to sell to a particular segment;
- d) the vendor incurs a fixed cost if he wishes to sell a particular product, regardless of whom it is sold to.

The model is applied to an example involving a vendor wishing to sell seven possible bundles to three different market segments: the home market, students, and the business market. The vendor has decided to give a 10% discount to the student segment and incurs a 5% selling fee for products sold in the home market segment:

```

MODEL:
  !Product pricing (PRICPROD);
  !Producer chooses prices to maximize producer
  surplus;
  !Each customer chooses the one
  product/bundle that maximizes consumer surplus;
SETS:
  CUST:
    SIZE, ! Each cust/market has a size;
    DISC, ! Discount off list price willing to
    give to I;
    DISD, ! Discount given to dealer(who sells
    full price);
    FM, ! Fixed cost of developing market I;
    YM, ! = 1 if we develop market I, else 0;
    SRP, ! Consumer surplus achieved by customer
    I;
  BUNDLE:
    COST, ! Each product/bundle has a cost/unit to
    producer;
    FP, ! Fixed cost of developing product J;
    YP, ! = 1 if we develop product J, else 0;
    PRICE, ! List price of product J;
    PMAX; ! Max price that might be charged;
  CXB( CUST, BUNDLE): RP, ! Reservation
  price of customer I for product J;
  EFP, ! Effective price I pays for J, = 0
  if not bought;
  X; ! = 1 if I buys J, else 0;
ENDSETS
DATA:
  ! The customer/market segments;
  CUST = HOME    STUD    BUS;
  ! Customer sizes;
  SIZE = 4000    3000    3000;
  ! Fixed market development costs;
  FM = 15000    12000    10000;
  ! Discount off list price to each customer, 0 <= DISC < 1;
  DISC = 0      .1      0;
  ! Discount/tax off list to each dealer, 0
  <= DISD < 1;
  DISD = .05    0      0;
  BUNDLE = B1   B2     B3   B12   B13   B23  B123;
  ! Reservation prices;
  RP = 400    50    200   450   650   250  700
      200    200    50   350   250   250  400
      500    100   100   550   600   260  600;
  ! Variable costs of each product bundle;

```

```

      COST = 100    20    30    120    130    50    150;
! Fixed product development costs;
      FP = 30000 40000 60000 10000 20000 8000    0;
ENDDATA
!-----;
! The seller wants to maximize the profit
  contribution;
[PROFIT] MAX =
@SUM( CXB( I, J):
  SIZE( I) * EFP( I, J)           ! Revenue;
  - COST( J) * SIZE( I) * X( I, J)
  ! Variable cost;
  - EFP( I, J) * SIZE( I) * DISD( I)
  ! Discount to dealers;
  - @SUM( BUNDLE: FP * YP)
  ! Product development cost;
  - @SUM( CUST: FM * YM);
  ! Market development cost;
! Each customer can buy at most 1 bundle;
@FOR( CUST( I):
  @SUM( BUNDLE( J) : X( I, J)) <= YM( I);
  @BIN( YM( I));
);
! Force development costs to be incurred
  if in market;
  @FOR( CXB( I, J): X( I, J) <= YP( J);
    ! for product J;
! The X's are binary, yes/no, 1/0 variables;
  @BIN( X( I, J));
);
! Compute consumer surplus for customer I;
@FOR( CUST( I): SRP( I)
  = @SUM( BUNDLE( J): RP( I, J) * X( I, J)
  - EFP( I, J));
! Customer chooses maximum consumer surplus;
@FOR( BUNDLE( J):
  SRP( I) >= RP( I, J)
  - ( 1 - DISC( I)) * PRICE( J)
  );
);
! Force effective price to take on proper value;
@FOR( CXB( I, J):
! zero if I does not buy J;
  EFP( I, J) <= X( I, J) * RP( I, J);
! cannot be greater than price;
  EFP( I, J) <= ( 1 - DISC( I)) * PRICE( J);
! cannot be less than price if bought;
  EFP( I, J) >= ( 1 - DISC( I)) * PRICE( J)
  - ( 1 - X( I, J)) * PMAX( J);
);
! Compute upper bounds on prices;
@FOR( BUNDLE( J): PMAX( J)
  = @MAX( CUST( I): RP( I, J)/(1 - DISC( I)));

```

```
);
END
```

The solution, in part, is:

```
Global optimal solution found at step:          146
Objective value:                             3895000.
Branch count:                                 0
```

Variable	Value	Reduced Cost
PRICE(B1)	500.0000	0.0000000
PRICE(B2)	222.2222	0.0000000
PRICE(B3)	200.0000	0.0000000
PRICE(B12)	550.0000	0.0000000
PRICE(B13)	650.0000	0.0000000
PRICE(B23)	277.7778	0.0000000
PRICE(B123)	700.0000	0.0000000
X(HOME, B123)	1.000000	-2060000.
X(STUD, B23)	1.000000	-592000.0
X(BUS, B12)	1.000000	-1280000.

In summary, the home segment buys product bundle *B123* at a price of \$700. The student segment buys product bundle *B23* at a list price of \$277.78, (i.e., a discounted price of \$250). The business segment buys product bundle *B12* at a price of \$550.

The prices of all other bundles can be set arbitrarily large. You can verify each customer is buying the product bundle giving the best deal:

Cust	Reservation price minus actual price		
	B12	B23	B123
Hom	$450 - 550 = -100$	$250 - 277.78 = -27.78$	$700 - 700 = 0$
Std	$350 - 9 * 550 = -145$	$250 - 9 * 277.78 = 0$	$400 - .9 * 700 = -230$
Bus	$550 - 550 = 0$	$260 - 277.78 = -17.78$	$600 - 700 = -100$

The vendor makes a profit of \$3,895,000. In contrast, if no bundling is allowed, the vendor makes a profit of \$2,453,000.

There may be other equilibrium solutions. However, the above solution is one that maximizes the profits of the vendor. An equilibrium such as this, where one of the players is allowed to select the equilibrium most favorable to that player, is called a Stackelberg equilibrium.

An implementation issue that one should be concerned with when using bundle pricing is the emergence of third party brokers who will buy your bundle, split it, and sell the components for a profit. For our example, a broker might buy the full bundle *B123* for \$700, sell the *B1* component for \$490 to the Business market, sell the *B2* component for \$190 (after discount) to the student market, sell the *B3* component to the Home market for \$190, and make a profit of $490 + 190 + 190 - 700 = \170 . The consumers should be willing to buy these components from the broker because their consumer surplus is \$10, as compared to the zero consumer surplus when buying the bundles. This generally legal (re-)selling of different versions of the products to consumers in ways not intended by the seller is sometimes known as a "gray market", as compared to a black market where clearly illegal sales take place. Bundle pricing is a generalization of quantity discount pricing (e.g., "buy one, get the second one for half price") where the bundle happens to contain identical products. The same sort of gray market possibility exists with quantity discounts. The seller's major protection against gray markets is to make sure that the transaction costs of breaking up and reselling

the components are too high. For example, if the only way of buying software is pre-installed on a computer, then the broker would have to setup an extensive operation to uninstall the bundled software and then reinstall the reconfigured software.

15.6 General Equilibrium Models of An Economy

When trade agreements are being negotiated between countries, each country is concerned with how the agreement will affect various industries in the country. A tool frequently used for answering such questions is the general equilibrium model. In a general equilibrium model of an economy, one wants to simultaneously determine prices and production quantities for several goods. The goods are consumed by several market sectors. Goods are produced by a collection of processes. Each process produces one or more goods and consumes one or more goods. At an equilibrium, a process will be used only if the value of the goods produced at least equals the cost of the goods required by the process.

When two or more countries are contemplating lowering trade barriers, they may want to look at general equilibrium models to get some estimates of how various industries will fare in the different countries as the markets open up.

An example based on two production processes producing four goods for consumption in four consumption sectors is shown below. Each sector has a demand curve for each good, based on the price of each good. Each production process in the model below is linear (i.e., it produces one or more goods from one or more of the other goods). A production process will not be used if the cost of raw materials and production exceeds the market value of the goods produced. The questions are: What is the clearing price for each good, and how much of each production process will be used?

```

MODEL:
! General Equilibrium Model of an economy, (GENEQLB1);
! Data based on Kehoe, Math Prog, Study 23(1985);
! Find clearing prices for commodities/goods and
  equilibrium production levels for processes in
  an economy;
SETS:
GOOD: PRICE, H;
SECTOR;
GXS( GOOD, SECTOR): ALPHA, W;
PROCESS: LEVEL, RC;
GXP( GOOD, PROCESS): MAKE;
ENDSETS
DATA:
GOOD = 1..4; SECTOR = 1..4;
! Demand curve parameter for each good i & sector j;
ALPHA =
.5200 .8600 .5000 .0600
.4000 .1 .2 .25
.04 .02 .2975 .0025
.04 .02 .0025 .6875;
! Initial wealth of good i by for sector j;
W =
50 0 0 0
0 50 0 0
0 0 400 0
0 0 0 400;
PROCESS= 1 2; ! There are two processes to make goods;
!Amount produced of good i per unit of process j;
MAKE =
6 -1
-1 3
-4 -1
-1 -1;
! Weights for price normalization constraint;
H = .25 .25 .25 .25;
ENDDATA
!-----;
! Variables:
LEVEL(p) = level or amount at which we operate
  process p.
RC(p) = reduced cost of process p,
  = cost of inputs to process p - revenues from outputs
  of process p, per unit.
PRICE(g) = equilibrium price for good g;
! Constraints;
! Supply = demand for each good g;
@FOR( GOOD( G):
@SUM( SECTOR( M): W( G, M))
+ @SUM( PROCESS( P): MAKE( G, P) * LEVEL( P))
= @SUM( SECTOR( S):
ALPHA( G, S) *

```

```

        @SUM( GOOD( I): PRICE( I) * W( I, S))/ PRICE( G));
    );
! Each process at best breaks even;
@FOR( PROCESS( P):
    RC(P) = @SUM( GOOD( G): - MAKE( G, P) * PRICE( G));
! Complementarity constraints. If process p
  does not break even(RC > 0), then do not use it;
    RC(P)*LEVEL(P) = 0;
    );
! Prices scale to 1;
    @SUM( GOOD( G): H( G) * PRICE( G)) = 1;
! Arbitrarily maximize some price to get a unique solution;
Max = PRICE(1);
END

```

The complementarity constraints, $RC(P) * LEVEL(P) = 0$, make this model difficult to solve for a traditional nonlinear solver. If the Global Solver option in LINGO is used, then this model is easily solved, giving the clearing prices:

PRICE(1)	1.100547
PRICE(2)	1.000000
PRICE(3)	1.234610
PRICE(4)	0.6648431

and the following production levels for the two processes:

LEVEL(1)	53.18016
LEVEL(2)	65.14806

This model in fact has three solutions, see Kehoe (1985). The other two are

PRICE(1)	0.6377
PRICE(2)	1.0000
PRICE(3)	0.1546
PRICE(4)	2.2077

and:

Variable	Value
PRICE(1)	1.0000
PRICE(2)	1.0000
PRICE(3)	1.0000
PRICE(4)	1.0000

Which solution you get may depend upon the objective function provided.

15.7 Transportation Equilibria

When designing a highway or street system, traffic engineers usually use models of some sophistication to predict the volume of traffic and the expected travel time on each link in the system. For each link, the engineers specify estimated average travel time as a nondecreasing function of traffic volume on the link.

The determination of the volume on each link is usually based upon a rule called Wardrop's Principle: If a set of commuters wish to travel from A to B , then the commuters will take the shortest

route in the travel time sense. The effect of this is, if there are alternative routes from A to B , commuters will distribute themselves over these two routes, so either travel times are equal over the two alternates or none of the A to B commuters use the longer alternate.

As an example, consider the network in Figure 15.2. Six units of traffic (e.g., in thousands of cars) want to get from A to B .

This is a network with congestion, that is, travel time on a link increases as the volume of traffic increases. The travel time on any link as a function of the traffic volume is given in the following table:

For All Traffic Volumes Less-Than-or-Equal-To	Link Travel Time in Minutes				
	AB	AC	BC	BD	CD
2	20	52	12	52	20
3	30	53	13	53	30
4	40	54	14	54	40

The dramatically different functions for the various links might be due to such features as number of lanes or whether a link has traffic lights or stop signs.

We are interested in how traffic will distribute itself over the three possible routes ABD , ACD , and $ABCD$ if each unit behaves individually optimally. That is, we want to find the flows for which a user is indifferent between the three routes:

Figure 15.2 A Transportation Network

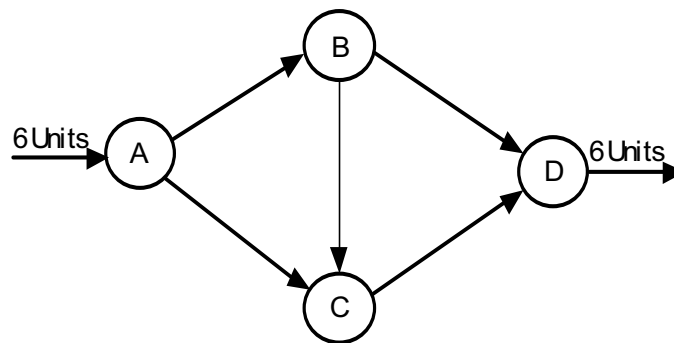

This can be formulated as an LP analogous to the previous equilibrium problems if the travel time schedules are interpreted as supply curves.

Define variables as follows. Two-letter variable names (e.g., AB or CD) denote the total flow along a given arc (e.g., the arc AB or the arc CD). Variables with a numeric suffix denote the incremental flow along a link. For example, AB_2 measures flow up to 2 units on link $A \rightarrow B$. AB_3 measures the incremental flow above 2, but less than 3.

The formulation is then:

$$\begin{aligned}
 \text{MIN} = & 20 * AB_2 + 30 * AB_3 + 40 * AB_4 + 52 * AC_2 \\
 & + 53 * AC_3 + 54 * AC_4 + 12 * BC_2 + 13 * BC_3 \\
 & + 14 * BC_4 + 52 * BD_2 + 53 * BD_3 + 54 * BD_4 \\
 & + 20 * CD_2 + 30 * CD_3 + 40 * CD_4;
 \end{aligned}$$

```

! Minimize sum of congestion of incremental units;
- AB2 - AB3 - AB4 + AB = 0;
  !Definition of AB;
- AC2 - AC3 - AC4 + AC = 0;
- BC2 - BC3 - BC4 + BC = 0;
- BD2 - BD3 - BD4 + BD = 0;
- CD2 - CD3 - CD4 + CD = 0;
  AB + AC = 6;
!Flow out of A;
  AB - BC - BD = 0;
!Flow through B;
  AC + BC - CD = 0;
!Flow through C;
  BD + CD = 6;
!Flow into D;
  AB2 <= 2;
  !Definition of the steps in;
  AB3 <= 1;
  !supply cost schedule;
  AB4 <= 1;
  AC2 <= 2;
  AC3 <= 1;
  AC4 <= 1;
  BC2 <= 2;
  BC3 <= 1;
  BC4 <= 1;
  BD2 <= 2;
  BD3 <= 1;
  BD4 <= 1;
  CD2 <= 2;
  CD3 <= 1;
  CD4 <= 1;

```

The objective requires a little bit of explanation. It minimizes the incremental congestion seen by each incremental individual unit as it “selects” its route. It does not take into account the additional congestion that the incremental unit imposes on units already taking the route. Because additional traffic typically hurts rather than helps, this suggests this objective will understate true total congestion costs. Let us see if this is the case.

The solution is:

Objective Value	452.0000000	
Variable	Value	Reduced Cost
AB2	2.000000	0.000000
AB3	1.000000	0.000000
AB4	1.000000	0.000000
AC2	2.000000	0.000000
AC3	0.000000	1.000000
AC4	0.000000	2.000000
BC2	2.000000	0.000000
BC3	0.000000	1.000000
BC4	0.000000	2.000000
BD2	2.000000	0.000000
BD3	0.000000	1.000000
BD4	0.000000	2.000000
CD2	2.000000	0.000000
CD3	1.000000	0.000000
CD4	1.000000	0.000000
AB	4.000000	0.000000
AC	2.000000	0.000000
BC	2.000000	0.000000
BD	2.000000	0.000000
CD	4.000000	0.000000
Row	Slack	Dual Prices
2)	0.000000	40.000000
3)	0.000000	52.000000
4)	0.000000	12.000000
5)	0.000000	52.000000
6)	0.000000	40.000000
7)	0.000000	-92.000000
8)	0.000000	52.000000
9)	0.000000	40.000000
10)	0.000000	0.000000
11)	0.000000	20.000000
12)	0.000000	10.000000
13)	0.000000	0.000000
14)	0.000000	0.000000
15)	1.000000	0.000000
16)	1.000000	0.000000
17)	0.000000	0.000000
18)	1.000000	0.000000
19)	1.000000	0.000000
20)	0.000000	0.000000
21)	1.000000	0.000000
22)	1.000000	0.000000
23)	0.000000	20.000000
24)	0.000000	10.000000
25)	0.000000	0.000000

Notice 2 units of traffic take each of the three possible routes: *ABD*, *ABCD*, and *ACD*. The travel time on each route is 92 minutes. This agrees with our understanding of an equilibrium (i.e., no user is motivated to take a different route). The total congestion is $6 \times 92 = 552$, which is greater than the 452

value of the objective of the LP. This is, as we suspected, because the objective measures the congestion incurred by the incremental unit. The objective function value has no immediate practical interpretation for this formulation. In this case, the objective function is simply a device to cause Wardrop's principle to hold when the objective is optimized.

The solution approach based on formulating the traffic equilibrium problem as a standard LP was presented mainly for pedagogical reasons. For larger, real-world problems, there are highly specialized procedures (cf., Florian (1977)).

15.7.1 User Equilibrium vs. Social Optimum

We shall see, for this problem, the solution just displayed does not minimize total travel time. This is a general result: the so-called user equilibrium, wherein each player in a system behaves optimally, need not result in a solution as good as a social optimum, which is best overall in some sense. Indeed, the user equilibrium need not even be Pareto optimal. In order to minimize total travel time, it is useful to prepare a table of total travel time incurred by users of a link as a function of link volume. This is done in the following table, where "Total" is the product of link volume and travel time at that volume:

Total and Incremental Travel Time Incurred on a Link										
Traffic Volume	AB		AC		BC		BD		CD	
	Total	Rate/Unit	Total	Rate/Unit	Total	Rate/Unit	Total	Rate/Unit	Total	Rate/Unit
2	40	20	104	52	24	12	104	52	40	20
3	90	50	159	55	39	15	159	55	90	50
4	160	70	216	57	56	17	216	57	160	70

The appropriate formulation is:

```

MIN = 20 * AB2 + 50 * AB3 + 70 * AB4 + 52 * AC2
      + 55 * AC3 + 57 * AC4 + 12 * BC2 + 15 * BC3
      + 17 * BC4 + 52 * BD2 + 55 * BD3 + 57 * BD4
      + 20 * CD2 + 50 * CD3 + 70 * CD4;
! Minimize total congestion;
- AB2 - AB3 - AB4 + AB = 0 ;
! Definition of AB;
- AC2 - AC3 - AC4 + AC = 0 ;
! and AC;
  BC2 - BC3 - BC4 + BC = 0 ;
! BC;
- BD2 - BD3 - BD4 + BD = 0 ;
! BD;
- CD2 - CD3 - CD4 + CD = 0 ;
! and CD;
  AB + AC = 6;
! Flow out of A;
  AB - BC - BD = 0;
! Flow through B;
  AC + BC - CD = 0 ;
! Flow through C;
  BD + CD = 6 ;

```

```

! Flow into D;
  AB2 <= 2;
! Steps in supply schedule;
  AB3 <= 1;
  AB4 <= 1;
  AC2 <= 2;
  AC3 <= 1;
  AC4 <= 1;
  BC2 <= 2;
  BC3 <= 1;
  BC4 <= 1;
  BD2 <= 2;
  BD3 <= 1;
  BD4 <= 1;
  CD2 <= 2;
  CD3 <= 1;
  CD4 <= 1;

```

The solution is:

```

Optimal solution found at step:      16
Objective value:                    498.0000

```

Variable	Value	Reduced Cost
AB2	2.000000	0.000000
AB3	1.000000	0.000000
AB4	0.000000	0.000000
AC2	2.000000	0.000000
AC3	1.000000	0.000000
AC4	0.000000	0.000000
BC2	0.000000	0.000000
BC3	0.000000	27.00000
BC4	0.000000	29.00000
BD2	2.000000	0.000000
BD3	1.000000	0.000000
BD4	0.000000	0.000000
CD2	2.000000	0.000000
CD3	1.000000	0.000000
CD4	0.000000	0.000000
AB	3.000000	0.000000
AC	3.000000	0.000000
BC	0.000000	1.000000
BD	3.000000	0.000000
CD	3.000000	0.000000

Row	Slack or Surplus	Dual Price
1	498.0000	1.000000
2	0.000000	70.00000
3	0.000000	57.00000
4	0.000000	-12.00000
5	0.000000	57.00000
6	0.000000	70.00000
7	0.000000	-70.00000
8	0.000000	0.000000
9	0.000000	13.00000

10	0.0000000	-57.00000
11	0.0000000	50.00000
12	0.0000000	20.00000
13	1.0000000	0.0000000
14	0.0000000	5.0000000
15	0.0000000	2.0000000
16	1.0000000	0.0000000
17	2.0000000	0.0000000
18	1.0000000	0.0000000
19	1.0000000	0.0000000
20	0.0000000	5.0000000
21	0.0000000	2.0000000
22	1.0000000	0.0000000
23	0.0000000	50.00000
24	0.0000000	20.00000
25	1.0000000	0.0000000

An interesting feature is no traffic uses link BC . Three units each take routes ABD and ACD . Even more interesting is the fact that the travel time on both routes is 83 minutes. This is noticeably less than the 92 minutes for the previous solution. With this formulation, the objective function measures the total travel time incurred. Note $498/6 = 83$.

If link BC were removed, this latest solution would also be a user equilibrium because no user would be motivated to switch routes. The interesting paradox is that, by adding additional capacity, in this case link BC , to a transportation network, the total delay may actually increase. This is known as Braess's Paradox (cf., Braess (1968) or Murchland (1970)). Murchland claims that this paradox was observed in Stuttgart, Germany when major improvements were made in the road network of the city center. When a certain cross street was closed, traffic got better.

To see why the paradox occurs, consider what happens when link BC is added. One of the 3 units taking route ABD notices that travel time on link BC is 12 and time on link CD is 30. This total of 42 minutes is better than the 53 minutes the unit is suffering in link BD , so the unit replaces link BD in its route by the sequence BCD . At this point, one of the units taking link AC observes it can reduce its delay in getting to C by replacing link AC (delay 53 minutes) with the two links AB and BC (delay of $30 + 12 = 42$). Unfortunately (and this is the cause of Braess's paradox), neither of the units that switched took into account the effect of their actions on the rest of the population. The switches increased the load on links AB and CD , two links for which increased volume dramatically increases the travel time of everyone. The general result is, *when individuals each maximize their own objective function, the obvious overall objective function is not necessarily maximized.*

15.8 Equilibria in Networks as Optimization Problems

For physical systems, it is frequently the case that the equilibrium state is one that minimizes the energy loss or the energy level. This is illustrated in the model below for an electrical network. Given a set of resistances in a network, if we minimize the energy dissipated, then we get the equilibrium flow. In the network model corresponding to this model, a voltage of 120 volts is applied to node 1. The dual prices at a node are the voltages at that node:

:

```
MODEL:
! Model of voltages and currents in a Wheatstone
  Bridge;
DATA:
  R12 = 10;
  R13 = 15;
  R23 = 8;
  R32 = 8;
  R24 = 20;
  R34 = 16;
ENDDATA
! Minimize the energy dissipated;
MIN = (I12 * I12 * R12 + I13 * I13 * R13
      + I23 * I23 * R23 + I24 * I24 * R24
      + I32 * I32 * R32 + I34 * I34 * R34) / 2
      - 120 * I01;
[NODE1] I01 = I12 + I13;
[NODE2] I12 + I32 = I23 + I24;
[NODE3] I13 + I23 = I32 + I34;
[NODE4] I24 + I34 = I45;
END
```

```

Optimal solution found at step:      13
Objective value:                    -479.5393
Variable          Value          Reduced Cost
R12              10.00000         0.0000000
R13              15.00000         0.0000000
R23              8.000000         0.0000000
R32              8.000000         0.0000000
R24              20.00000         0.0000000
R34              16.00000         0.0000000
I12              4.537428         0.0000000
I13              3.454894         0.0000000
I23              0.8061420         0.1504372E-05
I24              3.731286         0.2541348E-05
I32              0.0000000         6.449135
I34              4.261036         0.1412317E-05
I01              7.992322         0.0000000
I45              7.992322         0.0000000
Row      Slack or Surplus      Dual Price
  1      -479.5393              1.000000
NODE1    0.0000000              120.0000
NODE2    0.0000000              74.62572
NODE3    0.0000000              68.17658
NODE4    0.0000000              0.0000000

```

15.8.1 Equilibrium Network Flows

Another network setting involving nonlinearities is in computing equilibrium flows in a network. Hansen, Madsen, and H.B. Nielsen (1991) give a good introduction. The laws governing the flow depend upon the type of material flowing in the network (e.g., water, gas, or electricity). Equilibrium in a network is described by two sets of values:

- a) flow through each arc;
- b) pressure at each node (e.g., voltage in an electrical network).

At an equilibrium, the values in (a) and (b) must satisfy the rules or laws that determine an equilibrium in a network. In general terms, these laws are:

- i. for each node, standard conservation of flow constraints apply to the flow values;
- ii. for each arc, the pressure difference between its two endpoint nodes is related to the flow over the arc and the resistance of the arc.

In an electrical network, for example, condition (ii) says the voltage difference, V , between two points connected by a wire with resistance in ohms, R , over which a current of I amperes flows, must satisfy the constraint: $V = I \times R$.

The constraints (ii) tend to be nonlinear. The following model illustrates by computing the equilibrium in a simple water distribution network for a city. Pumps apply a specified pressure at two nodes, G and H . At the other nodes, water is removed at specified rates. We want to determine the implied flow rate on each arc and the pressure at each node:

```

MODEL:
! Network equilibrium NETEQL2:based on
  Hansen et al., math. Prog. vol. 52, no.1;
SETS:

```

```

NODE: DL, DU, PL, PU, P, DELIVER; ! P = Pressure at this node;
ARC( NODE, NODE): R, FLO; ! FLO = Flow on this arc;
ENDSETS
DATA:
NODE = A, B, C, D, E, F, G, H;
! Lower & upper limits on demand at each node;
DL = 1 2 4 6 8 7 -9999 -9999;
DU = 1 2 4 6 8 7 9999 9999;
! Lower & upper limits on pressure at each node;
PL = 0 0 0 0 0 0 240 240;
PU = 9999 9999 9999 9999 9999 9999 240 240;

! The arcs available and their resistance parameter;
ARC = B A, C A, C B, D C, E D, F D, G D, F E, H E, G F, H F;
R = 1, 25, 1, 3, 18, 45, 1, 12, 1, 30, 1;

PPAM = 1; ! Compressibility parameter;
!For incompressible fluids and electricity: PPAM = 1, for gases: PPAM
= 2;
FPAM = 1.852; !Resistance due to flow parameter;
! electrical networks: FPAM = 1;
! other fluids: 1.8 <= FPAM <= 2;
! For optimization networks: FPAM=0, for arcs with flow>=0;
ENDDATA

@FOR( NODE( K): ! For each node K;
! Bound the pressure;
@BND( PL(K), P(K), PU(K));
! Flow in = amount delivered + flow out;
@SUM( ARC( I, K): FLO( I, K)) = DELIVER( K) +
@SUM( ARC( K, J): FLO( K, J));
! Bound on amount delivered at each node;
@BND( DL(K), DELIVER(K), DU(K));
);

@FOR( ARC( I, J):
! Flow can go either way;
@FREE( FLO(I,J));
! Relate pressures at 2 ends to flow over arc;
P(I)^ PPAM - P(J)^ PPAM =
R(I,J)* @SIGN(FLO(I,J))* @ABS( FLO(I,J))^ FPAM;);
END

```

Verify the following solution satisfies conservation of flow at each node and the pressure drop over each arc satisfies the resistance equations of the model:

```

Feasible solution found at step:      22
Variable      Value
  PPAM        1.000000
  FPAM        1.852000
  P( A)       42.29544
  P( B)       42.61468
  P( C)       48.23412
  P( D)       158.4497

```

P (E)	188.0738
P (F)	197.3609
P (G)	240.0000
P (H)	240.0000
FLO (B, A)	0.5398153
FLO (C, A)	0.4601847
FLO (C, B)	2.539815
FLO (D, C)	7.000000
FLO (E, D)	1.308675
FLO (F, D)	0.9245077
FLO (F, E)	0.8707683
FLO (G, D)	10.76682
FLO (G, F)	1.209051
FLO (H, E)	8.437907
FLO (H, F)	7.586225

15.9 Problems

1. Producer B in the two-producer, two-consumer market at the beginning of the chapter is actually a foreign producer. The government of the importing country is contemplating putting a \$0.60 per unit tax on units from Producer B .
 - a) How is the formulation changed?
 - b) How is the equilibrium solution changed?
2. An organization is interested in selling five parcels of land, denoted A , B , C , D , and E , which it owns. It is willing to accept offers for subsets of the five parcels. Three buyers, x , y , and z are interested in making offers. In the privacy of their respective offices, each buyer has identified the maximum price he would be willing to pay for various combinations. This information is summarized below:

Buyer	Parcel Combination	Maximum Price
x	A, B, D	95
x	C, D, E	80
y	B, E	60
y	A, D	82
z	B, D, E	90
z	C, E	71

Each buyer wants to buy at most one parcel combination. Suppose the organization is a government and would like to maximize social welfare. What is a possible formulation based on an LP for holding this auction?

3. Commuters wish to travel from points A , B , and C to point D in the network shown in Figure 15.3:

Figure 15.3 A Travel Network

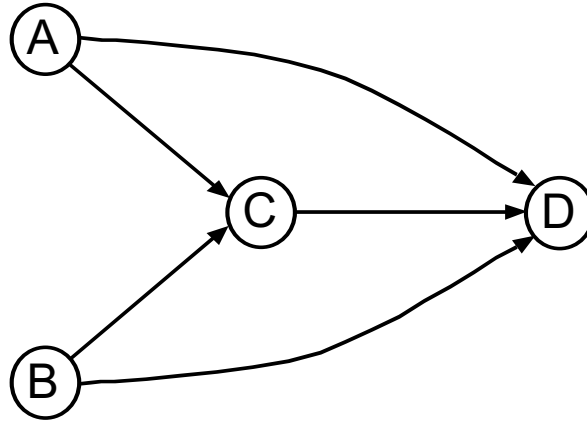

Three units wish to travel from A to D , two units from B to D , and one from C to D . The travel times on the five links as a function of volume are:

For All Volumes Less-Than-or-Equal-To:	Link Travel Time in Minutes				
	AC	AD	BC	BD	CD
2	21	50	17	40	12
3	31	51	27	41	13
4	41	52	37	42	14

- Display the LP formulation corresponding to a Wardrop's Principle user equilibrium.
- Display the LP formulation useful for the total travel time minimizing solution.
- What are the solutions to (a) and (b)?

4. In the sale of real estate and in the sale of rights to portions of the radio frequency spectrum, the value of one item to a buyer may depend upon which other items the buyer is able to buy. A method called a combinatorial auction is sometimes used in such cases. In such an auction, a bidder is allowed to submit a bid on a combination of items. The seller is then faced with the decision of which combination of these "combination" bids to select. Consider the following situation. The Duxbury Ranch is being sold for potential urban development. The ranch has been divided into four parcels, *A*, *B*, *C*, and *D* for sale. Parcels *A* and *B* both face major roads. Parcel *C* is a corner parcel at the intersection of the two roads. *D* is an interior parcel with a narrow access to one of the roads. The following bids have been received for various combinations of parcels:

Bid No.	Amount	Parcels Desired
1	\$380,000	A, C
2	\$350,000	A, D
3	\$800,000	A, B, C, D
4	\$140,000	B
5	\$120,000	B, C
6	\$105,000	B, D
7	\$210,000	C
8	\$390,000	A, B
9	\$205,000	D
10	\$160,000	A

Which combination of bids should be selected to maximize revenues, subject to not selling any parcel more than once?

5. Perhaps the greatest German writer ever was Johann Wolfgang von Goethe. While trying to sell one of his manuscripts to a publisher, Vieweg, he wrote the following note to the publisher: "Concerning the royalty, we will proceed as follows: I will hand over to Mr. Counsel Bottiger a sealed note, which contains my demand, and I wait for what Mr. Vieweg will suggest to offer for my work. If his offer is lower than my demand, then I take my note back, unopened, and the negotiation is broken. If, however, his offer is higher, then I will not ask for more than what is written in the note to be opened by Mr. Bottiger."(see Moldovanu and Tietzel (1998)). If you were the publisher, how would you decide how much to bid?

Game Theory and Cost Allocation

16.1 Introduction

In most decision-making situations, our profits (and losses) are determined not only by our decisions, but by the decisions taken by outside forces (e.g., our competitors, the weather, etc.). A useful classification is whether the outside force is indifferent or mischievous. We, for example, classify the weather as indifferent because its decision is indifferent to our actions, in spite of how we might feel during a rainstorm after washing the car and forgetting the umbrella. A competitor, however, generally takes into account the likelihood of our taking various decisions and as a result tends to make decisions that are mischievous relative to our welfare. In this chapter, we analyze situations involving a mischievous outside force. The standard terminology applied to the problem to be considered is *game theory*. Situations in which these problems might arise are in the choice of a marketing or price strategy, international affairs, military combat, and many negotiation situations. For example, the probability a competitor executes an oil embargo against us probably depends upon whether we have elected a strategy of building up a strategic petroleum reserve. Frequently, the essential part of the problem is deciding how two or more cooperating parties “split the pie”. That is, allocate costs or profits of a joint project. For a thorough introduction to game theory, see Fudenberg and Tirole (1993).

16.2 Two-Person Games

In so-called two-person game theory, the key feature is *each of the two players must make a crucial decision ignorant of the other player's decision*. Only after both players have committed to their respective decisions does each player learn of the other player's decision and each player receives a payoff that depends solely on the two decisions. Two-person game theory is further classified according to whether the payoffs are constant sum or variable sum. In a constant sum game, the total payoff summed over both players is constant. Usually this constant is assumed to be zero, so one player's gain is exactly the other player's loss. The following example illustrates a constant sum game.

A game is to be played between two players called *Blue* and *Gold*. It is a single simultaneous move game. Each player must make her single move in ignorance of the other player's move. Both moves are then revealed and then one player pays the other an amount specified by the payoff table below:

		Payoff from Blue to Gold	
		Blue's Move	
		a	b
		Gold's Move	a
b	-5		8
c	3		-4

Blue must choose one of two moves, (*a*) or (*b*), while Gold has a choice among three moves, (*a*), (*b*), or (*c*). For example, if Gold chooses move (*b*) and Blue chooses move (*a*), then Gold pays Blue 5 million dollars. If Gold chooses (*c*) and Blue chooses (*a*), then Blue pays Gold 3 million dollars.

16.2.1 The Minimax Strategy

This game does not have an obvious strategy for either player. If Gold is tempted to make move (*b*) in the hopes of winning the 8 million dollar prize, then Blue will be equally tempted to make move (*a*), so as to win 5 million from Gold. For this example, it is clear each player will want to consider a random strategy. Any player who follows a pure strategy of always making the same move is easily beaten. Therefore, define:

$$BM_i = \text{probability Blue makes move } i, i = a \text{ or } b,$$

$$GM_i = \text{probability Gold makes move } i, i = a, b, \text{ or } c.$$

How should Blue choose the probabilities BM_i ? Blue might observe that:

If Gold chooses move (*a*), my expected loss is:

$$4 BMA - 6 BMB.$$

If Gold chooses move (*b*), my expected loss is:

$$-5 BMA + 8 BMB.$$

If Gold chooses move (*c*), my expected loss is:

$$3 BMA - 4 BMB.$$

So, there are three possible expected losses depending upon which decision is made by Gold. If Blue is conservative, a reasonable criterion is to choose the BM_i , so as to minimize the maximum expected loss. This philosophy is called the *minimax strategy*. Stated another way, Blue wants to choose the probabilities BM_i , so, no matter what Gold does, Blue's maximum expected loss is minimized. If LB is the maximum expected loss to Blue, the problem can be stated as the LP:

```

MIN = LB;
! Probabilities must sum to 1;
      BMA      + BMB = 1;
! Expected loss if Gold chooses (a);
  -LB + 4 * BMA - 6 * BMB <= 0;
! Expected loss if Gold chooses (b);
  -LB - 5 * BMA + 8 * BMB <= 0;
! Expected loss if Gold chooses (c);
  -LB + 3 * BMA - 4 * BMB <= 0;

```

The solution is:

```

Optimal solution found at step:          2
Objective value:                        0.2000000
Variable      Value      Reduced Cost
  LB          0.2000000      0.0000000
  BMA         0.6000000      0.0000000
  BMB         0.4000000      0.0000000
Row   Slack or Surplus      Dual Price
  1   0.2000000             1.0000000
  2   0.0000000            -0.2000000
  3   0.2000000             0.0000000
  4   0.0000000             0.3500000
  5   0.0000000             0.6500000

```

The interpretation is, if Blue chooses move (a) with probability 0.6 and move (b) with probability 0.4, then Blue's expected loss is never greater than 0.2, regardless of Gold's move.

If Gold follows a similar argument, but phrases the argument in terms of maximizing the minimum expected profit, PG , instead of minimizing maximum loss, then Gold's problem is:

```

MAX = PG;
! Probabilities sum to 1;
      GMA      + GMB      + GMC      = 1;
! Expected profit if Blue chooses (a);
-PG + 4 * GMA - 5 * GMB + 3 * GMC >= 0;
! Expected profit if Blue chooses (b);
-PG - 6 * GMA + 8 * GMB - 4 * GMC >= 0;

```

The solution to Gold's problem is:

```

Optimal solution found at step:          1
Objective value:                        0.2000000
Variable      Value      Reduced Cost
  PG          0.2000000      0.0000000
  GMA         0.0000000      0.1999999
  GMB         0.3500000      0.0000000
  GMC         0.6500000      0.0000000
Row   Slack or Surplus      Dual Price
  1   0.2000000             1.0000000
  2   0.0000000             0.2000000
  3   0.0000000            -0.6000000
  4   0.0000000            -0.4000000

```

The interpretation is, if Gold chooses move (b) with probability 0.35, move (c) with probability 0.65 and never move (a), then Gold's expected profit is never less than 0.2. Notice Gold's lowest expected profit equals Blue's highest expected loss. From Blue's point of view the expected transfer to Gold is at least 0.2. The only possible expected transfer is then 0.2. This means if both players follow the random strategies just derived, then on every play of the game there is an expected transfer of 0.2 units from Blue to Gold. The game is biased in Gold's favor at the rate of 0.2 million dollars per play. The strategy of randomly choosing among alternatives to keep the opponent guessing, is sometimes also known as a mixed strategy.

If you look closely at the solutions to Blue's LP and to Gold's LP, you will note a surprising similarity. The dual prices of Blue's LP equal the probabilities in Gold's LP and the negatives of

Gold's dual prices equal the probabilities of Blue's LP. Looking more closely, you can note each LP is really the dual of the other one. This is always true for a two-person game of the type just considered and mathematicians have long been excited by this fact.

16.3 Two-Person Non-Constant Sum Games

There are many situations where the welfare, utility, or profit of one person depends not only on his decisions, but also on the decisions of others. A two-person game is a special case of the above in which:

1. there are exactly two players/decision makers,
2. each must make one decision,
3. in ignorance of the other's decision, and
4. the loss incurred by each is a function of both decisions.

A two-person constant sum game (frequently more narrowly called a zero sum game) is the special case of the above where:

- (4a) the losses to both are in the same commodity (e.g., dollars) and
- (4b) the total loss is a constant independent of players' decisions.

Thus, in a constant sum game the sole effect of the decisions is to determine how a "constant sized pie" is allocated. Ordinary linear programming can be used to solve two-person constant sum games.

When (1), (2) and (3) apply, but (4b) does not, then we have a two-person non-constant sum game. Ordinary linear programming cannot be used to solve these games. However, closely related algorithms, known as linear complementarity algorithms, are commonly applied. Sometimes a two-person non-constant sum game is also called a bimatrix game.

As an example, consider two firms, each of which is about to introduce an improved version of an already popular consumer product. The versions are very similar, so one firm's profit is very much affected by its own advertising decision as well as the decision of its competitor. The major decision for each firm is presumed to be simply the level of advertising. Suppose the losses (in millions of dollars) as a function of decision are given by Figure 16.1. The example illustrates that each player need not have exactly the same kinds of alternatives.

Figure 16.1 Two Person, Non-constant Sum Game

		Firm A		
		No Advertise	Advertise Medium	Advertise High
Firm B	No Advertise	-4 / -4	-3 / -2	-5 / 1
	Advertise	-1 / -5	-2 / -1	-1 / 0

Negative losses correspond to profits.

16.3.1 Prisoner's Dilemma

This cost matrix has the so-called prisoner's dilemma cost structure. This name arises from a setting in which two accomplices in crime find themselves in separate jail cells. If neither prisoner cooperates with the authorities (thus the two cooperate), both will receive a medium punishment. If one of them provides evidence against the other, the other will get severe punishment while the one who provides evidence will get light punishment, *if the other does not provide evidence against the first*. If each provides evidence against the other, they both receive severe punishment. Clearly, the best thing for the two as a group is for the two to cooperate with each other. However, individually there is a strong temptation to defect.

The prisoner's dilemma is common in practice, especially in advertising. The only way of getting to Mackinac Island in northern Michigan is via ferry from Mackinaw City. Three different companies, Sheplers, the Arnold Line, and the Star Line operate such ferries. As you approach Mackinaw City by car, you may notice up to a mile before the ferry landing, that each company has one or more small roadside stands offering to sell ferry tickets for their line. Frequent users of the ferry service proceed directly to the well-marked dock area and buy a ticket after parking the car and just before boarding the ferry (no cars are allowed on Mackinac Island). No reserved seats are sold, so there is no advantage to buying the tickets in advance at the stands. First time visitors, however, are tempted to buy a ticket at a company specific stand because the signs suggest that this is the safe thing to do. The "socially" most efficient arrangement would be to have no advanced ticket booths. If a company does not have a stand, however, while its competitors do, then this company will lose a significant fraction of the first time visitor market.

The same situation exists with the two firms in our little numerical example. For example, if *A* does not advertise, but *B* does, then *A* makes 1 million and *B* makes 5 million of profit. Total profit

would be maximized if neither advertised. However, if either knew the other would not advertise, then the one who thought he had such clairvoyance would have a temptation to advertise.

Later, it will be useful to have a loss table with all entries strictly positive. The relative attractiveness of an alternative is not affected if the same constant is added to all entries. Figure 16.2 was obtained by adding +6 to every entry in Figure 16.1:

Figure 16.2 Two Person, Non-constant Sum Game

		Firm A		
		No Advertise	Advertise Medium	Advertise High
Firm B	No Advertise	2 / 2	3 / 4	1 / 7
	Advertise	5 / 1	4 / 5	5 / 6

We will henceforth work with the data in Figure 16.2.

16.3.2 Choosing a Strategy

Our example illustrates that we might wish our own choice to be:

- i. somewhat unpredictable by our competitor, and
- ii. robust in the sense that, regardless of how unpredictable our competitor is, our expected profit is high.

Thus, we are lead (again) to the idea of a random or mixed strategy. By making our decision random (e.g., by flipping a coin) we tend to satisfy (i). By biasing the coin appropriately, we tend to satisfy (ii).

For our example, define a_1 , a_2 , a_3 as the probability A chooses the alternative “No advertise”, “Advertise Medium”, and “Advertise High”, respectively. Similarly, b_1 and b_2 are the probabilities that B applies to alternatives “No Advertise” and “Advertise”, respectively. How should firm A choose a_1 , a_2 , and a_3 ? How should firm B choose b_1 and b_2 ?

For a bimatrix game, it is difficult to define a solution that is simultaneously optimum for both. We can, however, define an equilibrium stable set of strategies. A stable solution has the feature that, given B 's choice for b_1 and b_2 , A is not motivated to change his probabilities a_1 , a_2 , and a_3 . Likewise, given a_1 , a_2 , and a_3 , B is not motivated to change b_1 and b_2 . Such a solution, where no player is

motivated to unilaterally change his or her strategy, is sometimes also known as a Nash equilibrium. There may be bimatrix games with several stable solutions.

What can we say beforehand about a strategy of A 's that is stable? Some of the a_i 's may be zero while for others we may have $a_i > 0$. An important observation which is not immediately obvious is the following: the expected loss to A of choosing alternative i is the same over all i for which $a_i > 0$. If this were not true, then A could reduce his overall expected loss by increasing the probability associated with the lower loss alternative. Denote the expected loss to A by v_A . Also, the fact that $a_i = 0$ must imply the expected loss from choosing i is $> v_A$. These observations imply that, with regard to A 's behavior, we must have:

$$\begin{aligned} 2b_1 + 5b_2 &\geq v_A \text{ (with equality if } a_1 > 0), \\ 3b_1 + 4b_2 &\geq v_A \text{ (with equality if } a_2 > 0), \\ b_1 + 5b_2 &\geq v_A \text{ (with equality if } a_3 > 0). \end{aligned}$$

Symmetric arguments for B imply:

$$\begin{aligned} 2a_1 + 4a_2 + 7a_3 &\geq v_B \text{ (with equality if } b_1 > 0), \\ a_1 + 5a_2 + 6a_3 &\geq v_B \text{ (with equality if } b_2 > 0). \end{aligned}$$

We also have the nonnegativity constraints:

$$a_i \geq 0 \text{ and } b_i \geq 0, \text{ for all alternatives } i.$$

Because the a_i and b_i are probabilities, we wish to add the constraints $a_1 + a_2 + a_3 = 1$ and $b_1 + b_2 = 1$.

If we explicitly add slack (or surplus if you wish) variables, we can write:

$$\begin{aligned} 2b_1 + 5b_2 - slka1 &= v_A \\ 3b_1 + 4b_2 - slka2 &= v_A \\ b_1 + 5b_2 - slka3 &= v_A \\ 2a_1 + 4a_2 + 7a_3 - slkb1 &= v_B \\ a_1 + 5a_2 + 6a_3 - slkb2 &= v_B \\ a_1 + a_2 + a_3 &= 1 \\ b_1 + b_2 &= 1 \\ a_i \geq 0, b_i \geq 0, slka_i \geq 0, \text{ and } slkb_i \geq 0, &\text{ for all alternatives } i. \\ slka1 * a1 &= 0 \\ slka2 * a2 &= 0 \\ slka3 * a3 &= 0 \\ slkb1 * b1 &= 0 \\ slkb2 * b2 &= 0 \end{aligned}$$

The last five constraints are known as the complementarity conditions. The entire model is known as a linear complementarity problem.

Rather than use a specialized linear complementarity algorithm, we will simply use the integer programming capabilities for LINGO to model the problem as follows:

```

MODEL: ! Two person nonconstant sum game.(BIMATRIX);
SETS:
  OPTA: PA, SLKA, NOTUA, COSA;
  OPTB: PB, SLKB, NOTUB, COSB;
  BXA( OPTB, OPTA): C2A, C2B;
ENDSETS
DATA:
  OPTB = BNAD BYAD;
  OPTA = ANAD AMAD AHAD;
  C2A = 2   3   1 ! C2A( I, J) = cost to A if B;
        5   4   5; ! chooses row I, A chooses col J;
  C2B = 2   4   7 ! C2B( I, J) = cost to B if B;
        1   5   6; ! chooses row I, A chooses col J;
ENDDATA
!-----;
! Conditions for A, for each option J;
@FOR( OPTA( J):
! Set CBSTA= cost of strategy J, if J is used by A;
  CBSTA = COSA( J) - SLKA( J);
  COSA( J) = @SUM( OPTB( I): C2A( I, J) * PB( I));
! Force SLKA( J) = 0 if strategy J is used;
  SLKA( J) <= NOTUA( J) * @MAX( OPTB( I):
    C2A( I, J));
! NOTUA( J) = 1 if strategy J is not used;
  PA( J) <= 1 - NOTUA( J);
! Either strategy J is used or it is not used;
  @BIN( NOTUA( J));
);
! A must make a decision;
@SUM( OPTA( J): PA( J)) = 1;
! Conditions for B;
@FOR( OPTB( I):
! Set CBSTB = cost of strategy I, if I is used by
  B;
  CBSTB = COSB( I) - SLKB( I);
  COSB( I) = @SUM( OPTA( J): C2B( I, J) * PA( J));
! Force SLKB( I) = 0 if strategy I is used;
  SLKB( I) <= NOTUB( I) * @MAX( OPTA( J):
    C2B( I, J));
! NOTUB( I) = 1 if strategy I is not used;
  PB( I) <= 1 - NOTUB( I);
! Either strategy I is used or it is not used;
  @BIN( NOTUB( I));
);
! B must make a decision;
@SUM( OPTB( I): PB( I)) = 1;
END

```

A solution is:

Variable	Value
CBSTA	3.666667
CBSTB	5.500000
PA (AMAD)	0.5000000
PA (AHAD)	0.5000000
SLKA (ANAD)	0.3333333
NOTUA (ANAD)	1.000000
COSA (ANAD)	4.000000
COSA (AMAD)	3.666667
COSA (AHAD)	3.666667
PB (BNAD)	0.3333333
PB (BYAD)	0.6666667
COSB (BNAD)	5.500000
COSB (BYAD)	5.500000

The solution indicates that firm *A* should not use option 1(No ads) and should randomly choose with equal probability between options 2 and 3. Firm *B* should choose its option 2(Advertise) twice as frequently as it chooses its option 1(Do not advertise).

The objective function value, reduced costs and dual prices can be disregarded. Using our original loss table, we can calculate the following:

Situation		Probability	Weighted Contribution To Total Loss of	
A	B		A	B
No Ads	No Ads	$0 \times 1/3$	0	0
No Ads	Ads	$0 \times 2/3$	0	0
Advertise Medium	No Ads	$1/2 \times 1/3$	$(1/6) \times (-3)$	$(1/6) \times (-2)$
Advertise Medium	Ads	$1/2 \times 2/3$	$(1/3) \times (-2)$	$(1/3) \times (-1)$
Advertise High	No Ads	$1/2 \times 1/3$	$(1/6) \times (-5)$	$(1/6) \times (1)$
Advertise	Ads	$1/2 \times 2/3$	$(1/3) \times (-1)$	$(1/3) \times (0)$
			<hr/> -2.3333	<hr/> -0.5

Thus, following the randomized strategy suggested, *A* would have an expected profit of 2.33 million; whereas, *B* would have an expected profit of 0.5 million. Contrast this with the fact that, if *A* and *B* cooperated, they could each have an expected profit of 4 million.

16.3.3 Bimatrix Games with Several Solutions

When a nonconstant sum game has multiple or alternative stable solutions, life gets more complicated. The essential observation is we must look outside our narrow definition of “stable solution” to decide which of the stable solutions, if any, would be selected in reality.

Consider the following nonconstant sum two-person game:

Figure 16.3 Bimatrix Games

Firm A

		Firm A	
		1	2
Firm B	1	200 200	160 10
	2	10 160	100 100

As before, the numbers represent losses.

First, observe the one solution that is stable according to our definition: (*I*) Firm *A* always chooses option 1 and Firm *B* always chooses option 2. Firm *A* is not motivated to switch to 2 because its losses would increase to 100 from 10. Similarly, *B* would not switch to 1 from 2 because its losses would increase to 200 from 160. The game is symmetric in the players, so similar arguments apply to the solution (*II*): *B* always chooses 1 and *A* always chooses 2.

Which solution would result in reality? It probably depends upon such things as the relative wealth of the two firms. Suppose:

- i. *A* is the wealthier firm,
- ii. the game is repeated week after week, and
- iii. currently the firms are using solution *II*.

After some very elementary analysis, *A* concludes it much prefers solution *I*. To move things in this direction, *A* switches to option 1. Now, it becomes what applied mathematicians call a game of “chicken”. Both players are taking punishment at the rate of 200 per week. Either player could improve its lot by $200 - 160 = 40$ by unilaterally switching to its option 2. However, its lot would be improved a lot more (i.e., $200 - 10 = 190$) if its opponent unilaterally switched. At this point, a rational *B* would probably take a glance at *A*’s balance sheet and decide *B* switching to option 2 is not such a bad decision. When a game theory problem has multiple solutions, any given player would like to choose that stable solution which is best for it. If the player has the wherewithal to force such a solution (e.g., because of its financial size), then this solution is sometimes called a Stackelberg equilibrium.

If it is not clear which firm is wealthier, then the two firms may decide a cooperative solution is best (e.g., alternate between solutions *I* and *II* in alternate weeks). At this point, however, federal antitrust authorities might express a keen interest in this bimatrix game.

We conclude a “stable” solution is stable only in a local sense. When there are multiple stable solutions, we should really look at all of them and take into account other considerations in addition to the loss matrix.

16.4 Nonconstant-Sum Games Involving Two or More Players

The most unrealistic assumption underlying classical two-person constant-sum game theory is the sum of the payoffs to all players must sum to zero (actually a constant, without loss of generality). In reality, the total benefits are almost never constant. Usually, total benefits increase if the players cooperate, so these situations are sometimes called cooperative games. In these nonconstant-sum games, the difficulty then becomes one of deciding how these additional benefits due to cooperation should be distributed among the players.

There are two styles for analyzing nonconstant sum games. If we restrict ourselves to two persons, then so-called bimatrix game theory extends the methods for two-person constant sum games to nonconstant sum games. If there are three or more players, then *n-person game theory* can be used in selecting a decision strategy. The following example illustrates the essential concepts of *n-person game theory*.

Three property owners, *A*, *B*, and *C*, own adjacent lakefront property on a large lake. A piece of property on a large lake has higher value if it is protected from wave action by a seawall. *A*, *B*, and *C* are each considering building a seawall on their properties. A seawall is cheaper to build on a given piece of property if either or both of the neighbors have seawalls. For our example, *A* and *C* already have expensive buildings on their properties. *B* does not have buildings and separates *A* from *C* (i.e., *B* is between *A* and *C*). The net benefits of a seawall for the three owners are summarized below:

Owners Who Cooperate, i.e., Build While Others Do Not	Net Benefit to Cooperating Owners
<i>A</i> alone	1.2
<i>B</i> alone	0
<i>C</i> alone	1
<i>A</i> and <i>B</i>	4
<i>A</i> and <i>C</i>	3
<i>B</i> and <i>C</i>	4
<i>A</i> , <i>B</i> , and <i>C</i>	7

Obviously, all three owners should cooperate and build a unified seawall because then their total benefits will be maximized. It appears *B* should be compensated in some manner because he has no motivation to build a seawall by himself. Linear programming can provide some help in selecting an acceptable allocation of benefits.

Denote by v_A , v_B , and v_C the net benefits, which are to be allocated to owners A , B , and C . No owner or set of owners will accept an allocation that is less than that, which they would enjoy if they acted alone. Thus, we can conclude:

$$\begin{aligned}v_A &\geq 1.2 \\v_B &\geq 0 \\v_C &\geq 1 \\v_A + v_B &\geq 4 \\v_A + v_C &\geq 3 \\v_B + v_C &\geq 4 \\v_A + v_B + v_C &\leq 7\end{aligned}$$

That is, any allocation satisfying the above constraints should be self-enforcing. No owner would be motivated to not cooperate. He cannot do better by himself. The above constraints describe what is called the “core” of the game. Any solution (e.g., $v_A = 3$, $v_B = 1$, $v_C = 3$) satisfying these constraints is said to be in the core.

Various objective functions might be appended to this set of constraints to give an LP. The objective could take into account secondary considerations. For example, we might choose to maximize the minimum benefit. The LP in this case is:

$$\begin{aligned}\text{Maximize } &z \\ \text{subject to } &z \leq v_A; z \leq v_B; z \leq v_C \\ &v_A \geq 1.2 \\ &v_C \geq 1 \\ &v_A + v_B \geq 4 \\ &v_A + v_C \geq 3 \\ &v_A + v_B + v_C \leq 7\end{aligned}$$

A solution is $v_A = v_B = v_C = 2.3333$.

Note the core can be empty. That is, there is no feasible solution. This would be true, for example, if the value of the coalition A, B, C was 5.4 rather than 7. This situation is rather interesting. Total benefits are maximized by everyone cooperating. However, total cooperation is inherently unstable when benefits are 5.4. There will always be a pair of players who find it advantageous to form a subcoalition and improve their benefits (at the considerable expense of the player left out). As an example, suppose the allocations to A, B , and C under full cooperation are 1.2, 2.1, and 2.1, respectively. At this point, A would suggest to B the two of them exclude C and cooperate between the two of them. A would suggest to B the allocation of 1.8, 2.2, and 1. This is consistent with the fact that A and B can achieve a total of 4 when cooperating. At this point, C might suggest to A that the two of them cooperate and thereby select an allocation of 1.9, 0, 1.1. This is inconsistent with the fact that A and C can achieve a total of 3 when cooperating. At this point, B suggests to C etc. Thus, when the core is empty, it may be everyone agrees that full cooperation can be better for everyone. There nevertheless must be an enforcement mechanism to prevent “greedy” members from pulling out of the coalition.

16.4.1 Shapley Value

Another popular allocation method for cooperative games is the Shapley Value. The rule for the Shapley Value allocation is that each player should be awarded his average marginal contribution to the coalition if one considers all possible sequences for forming the full coalition. The following table illustrates for the previous example:

<u>Sequence</u>	<u>Marginal value of player</u>		
	<u>A</u>	<u>B</u>	<u>C</u>
A B C	1.2	2.8	3
A C B	1.2	4	1.8
B A C	4	0	3
B C A	3	0	4
C A B	2	4	1
C B A	3	3	1
Total:	14.4	13.8	13.8
Average:	2.4	2.3	2.3

Thus, the Shapley value allocates slightly more, 2.4, to Player *A* in our example. For this example, as with most typical cooperative games, the Shapley Value allocation is in the core if the core is non-empty.

16.5 The Stable Marriage/Assignment Problem

The stable marriage problem is the multi-person interpretation of the assignment problem. Although the major application of the stable marriage model is in college admissions and large scale labor markets, the problem historically has been explained as the “marriage” problem of assigning each of n men to exactly one of n women, and vice versa. Instead of there being a single objective function, each man provides a preference ranking of each of the women, and each woman provides a ranking of each of the men. An assignment is said to be stable if for every man i , and woman j , either: a) man i prefers the woman he currently is assigned to over woman j , or b) woman j prefers the man she is currently assigned to over man i . Otherwise, man i and woman j would be motivated to abandon their current partners and “elope”. The stable marriage assignment method has been used for assigning medical residents and interns to hospitals in the U.S. since 1952. Each year, thousands of prospective interns rank each of the hospitals in which they are interested, and each hospital ranks each of the interns in which they are interested. Then a neutral agency, the National Resident Matching Program (NRMP) assigns interns to hospitals using methods described below. A similar system is used in Canada and Scotland. Norway and Singapore use a similar approach to assign students to schools and universities. Roth (1984) gives a very interesting history of how the U.S. medical profession came to use the stable marriage assignment method embodied in NRMP. Roth, Sonmez, and Unver(2005) describe the establishment of a system, based on the marriage assignment method, for matching kidney donors with people needing kidneys.

In any multi-player problem, the following questions should always be asked: a) Is there always a stable assignment or more generally an equilibrium solution? b) Can there be multiple stable solutions? c) If yes, what criterion should we use for choosing among the multiple solutions? d) Is the solution Pareto optimal, i.e., undominated? e) Is our method for solving the problem, in particular how we answer (c), incentive compatible? That is, does the method motivate the players to provide accurate input information, e.g., rankings, for our method?

We illustrate ideas with the following 3-man, 3-woman example from Gale and Shapley(1962). A 1 means most attractive. A 3 means least attractive.

```

MAN = ADAM BOB CHUCK;
WOMAN= ALICE BARB CARMEN;
! Men(row) preference for women(col);
MPREF =
    1   2   3  !ADAM;
    3   1   2  !BOB;
    2   3   1; !CHUCK;
! Women(col) preference for men(row);
WPREF =
    3   2   1 !ADAM;
    1   3   2 !BOB;
    2   1   3; !CHUCK;
! Thus, Adam's first choice is Alice.
  Alice's first choice is Bob;

```

We shall see from this example that the answer to question (b) is that, yes, there can be multiple stable solutions. In this example, giving each man his first choice (and incidentally, each woman her third choice) is feasible, giving the assignment: Adam with Alice, Bob with Barb, and Chuck with Carmen. It is stable because no man is motivated to switch. A second stable solution is possible by giving each woman her first choice (and incidentally, each man his third choice), namely: Adam with Carmen, Bob with Alice, and Chuck with Barb. It is stable because no woman is motivated to switch. A third, less obvious stable solution is to give everyone their second choice: Adam with Barb, Bob with Carmen, and Chuck with Alice. All other assignments are unstable.

How to solve the problem?

Gale and Shapley (1962) show that an intuitive iterative courtship type of method can be made into a rigorous algorithm for finding a stable assignment. The algorithm proceeds as follows:

- 1) Each man proposes, or is tentatively assigned, to his first choice woman.
- 2) If every woman has exactly one man assigned to her, then stop. We have a stable assignment.
- 3) Else, each woman who has two or more men assigned to her rejects all but one of the men assigned to her, tentatively keeping the one most attractive to her of the men that just proposed to her.
- 4) Each man just rejected in (3) proposes/is assigned to the next most attractive woman on his list.
- 5) Go to (2).

This version of the algorithm will produce the first solution mentioned above in which all men get their first choice. Obviously, there is the female version of this algorithm in which the roles of men and woman are exchanged. That version gives the second solution above. Gale and Shapley(1962) make the following observations: i) Regarding our question (a) above, this algorithm will always find a stable solution; ii) If both the male and the female versions of the algorithm give the same assignment, then that is the unique stable solution; iii) When men propose first, the solution is optimal for the men in the sense that there is no other stable solution in which any man does better. Similarly, the version in which women propose first, results in a solution that is optimal for women.

The two Gale/Shapley algorithms can only give a solution in which men are treated very well, or a solution in which women are treated very well. What about a solution in which everyone is treated “moderately well”? Vande Vate(1989) showed that it is possible to formulate the stable marriage assignment problem as a linear program. The key observation is: if we consider any man i and woman j in

a stable solution, then one of the following must hold: a) i and j are assigned to each other, or b) man i is assigned to some other woman k whom he prefers to j , or c) woman j is assigned to some man k whom she prefers to i . If none of (a), (b), and (c) hold, then i and j both prefer each other to their current mates and they are tempted to elope.

Define the parameters and sets:

$mpref_{ij}$ = the preference position of woman j for man i ,
e.g., if man 2's first choice is woman 3, then $mpref_{23} = 1$,

$wpref_{ij}$ = the preference position of man i for woman j ,
e.g., if woman 3's second choice is man 1, then $wpref_{13} = 2$,

$SM(i,j)$ = the set of women that man i prefers to woman j ,
= $\{ k : mpref_{ik} < mpref_{ij} \}$,

$SW(i,j)$ = the set of men that woman j prefers to man i ,
= $\{ k : mpref_{kj} < mpref_{ij} \}$,

Define the variables:

$y_{ij} = 1$ if man i and woman j are assigned to each other.

The "no eloping" stability conditions (a), (b), and (c) above correspond to the linear constraints:

For all men i and women j :

$$y_{ij} + \sum_{k \in SM(i,j)} y_{ik} + \sum_{k \in SW(k,j)} y_{kj}.$$

A remaining question is, what objective function should we use? We already saw a solution above in which men were treated well but women were treated poorly, and a solution in which women were treated well but men were treated poorly. How about a solution in which minimizes the worst that anyone gets treated? The following LINGO model illustrates.

```
! Stable Marriage Assignment (stable_marriage3);
SETS:
  MAN: AM;
  WOMAN: AW;
  MXW(MAN,WOMAN): MPREF, WPREF, Y, RM, RW;
ENDSETS
DATA:
! Example from Gale and Shapley(1962);
  MAN = ADAM BOB CHUCK;
  WOMAN= ALICE BARB CARMEN;
  ! Men(row) preference for women(col);
  MPREF =
      1   2   3 !ADAM;
      3   1   2 !BOB;
      2   3   1;!CHUCK;
  ! Women(col) preference for men(row);
  WPREF =
      3   2   1 !ADAM;
      1   3   2 !BOB;
      2   1   3;!CHUCK;
```

```

! Thus, Adam's first choice is Alice.
    Alice's first choice is Bob;
! This data set has 3 stable assignments;
ENDDATA
! Y(i,j) = 1 if man i is assigned to woman j;

! Each man must be assigned;
@FOR(MAN(i):
    @SUM(WOMAN(j): Y(i,j)) = 1;
);
! Each woman must be assigned;
@FOR(WOMAN(j):
    @SUM(MAN(i): Y(i,j)) = 1;
);

! Stability conditions: Either man i and woman are
    assigned to each other, or
    man i gets a woman k he prefers to j, or
    woman j, gets a man k she prefers to i;
@FOR( MXW(i,j):
    Y(i,j)
    + @SUM(WOMAN(k) | MPREF(i,k) #LT# MPREF(i,j): Y(i,k))
    + @SUM( MAN(k) | WPREF(k,j) #LT# WPREF(i,j): Y(k,j)) >= 1
);

! Compute actual assigned rank for each man and woman;
@FOR( MAN(i):
    AM(i) = @SUM( WOMAN(k): MPREF(i,k)*Y(i,k));
    PWORST >= AM(i);
);
@FOR(WOMAN(j):
    AW(j) = @SUM( MAN(k): WPREF(k,j)*Y(k,j));
    PWORST >= AW(j);
);

! Minimize the worst given to anyone;
MIN = PWORST;

```

When solved, we get the solution:

Variable	Value
Y(ADAM, BARB)	1.000000
Y(BOB, CARMEN)	1.000000
Y(CHUCK, ALICE)	1.000000

In the “Men first” solution, every woman got her third choice. In the “Woman first” solution, every man got his third choice. In this solution, the worst anyone gets is their second choice. In fact, everyone gets their second choice. McVitie and Wilson(1971) present an algorithm for efficiently enumerating all stable solutions.

For this example, we have an answer to question (d) above. It is easy to see that each of the three solutions is Pareto optimal. In the “Women first” solution, clearly the women cannot do any better,

and the men cannot do any better without hurting one of the women. Similar comments apply to the other two solutions.

With regard to the incentive compatibility question, (e) above, Roth, Rothblum, and Vande Vate provide a partial answer, namely, if the “Men first” algorithm is used then there is nothing to be gained by a man misrepresenting his preferences. This is somewhat intuitive in that if the “Men first” rule is used, then the resulting solution gives each man the best solution possible among all stable solutions. We may reasonably restrict ourselves to stable solutions. Thus, if some man misrepresents his preferences, this might cause a different stable solution to result in which this man might be treated worse, but definitely no better. Abdulkadiroglu, Pathak, and Roth(2005), mention that New York City, when assigning students to highschools, uses a “Students first” variant of the marriage assignment algorithm so as to motivate students to state their true preferences among highschools they are considering attending.

16.5.1 The Stable Room-mate Matching Problem

The stable room-mate problem is the multi-person interpretation of the 2-matching optimization problem. A college wants to match incoming freshman, two to a room in a freshman dormitory. Each student provides a ranking of all other potential room-mates. A matching is stable if there are no two students, i and j , who are not room-mates such that i prefers j to his current room-mate, and j prefers i to his current room-mate. The stable marriage problem can be interpreted as a special case of the room-mate matching problem in which people give very unattractive rankings to people of the same sex.

In contrast to the stable marriage problem, there need not be a stable solution to a stable room-mate problem. The following 4-person example due to Gale and Shapley(1962) illustrates a situation with no stable matching.

```
! Example from Gale and Shapley;
PERSON = AL   BOB  CAL DON;
! Row preference for col;
PREF =
      99  1  2  3
      2 99  1  3
      1  2 99  3
      1  2  3 99;
! E.g., AL
! The 99 is to indicate that a person cannot be
  matched to himself.
```

Consider, for example, the solution: AL with BOB, and CAL with DON. It is not stable because BOB is matched with his second choice and CAL is matched with his third choice, whereas if BOB and CAL got together, BOB would get his first choice and CAL would get his second choice. That would give us the solution BOB with CAL, and AL with DON. This is solution is not stable, however, because then AL and CAL would discover that they could improve their lot by getting together to give: AL with CAL, and BOB with DON. This solution is not stable, etc. In the terminology of game theory, the marriage assignment problem always has a core. The room-mate matching problem may not have a core.

Irving(1985) gives an efficient algorithm for detecting whether a room-mates problem has a stable matching, and if yes, finding a stable matching. The room-mates problem can also be solved by formulating it as a mathematical program as illustrated by the following LINGO model for finding a stable room-mate matching among 8 potential room-mates. This example from Irving(1985) has three stable matchings.

```

! Stable Roommate Matching(stable_roommate8);
! Each of 2n people specify a rank, 1, 2,..., 2n-1, for
each other person. We want to pair up the people into
a stable set of pairs, i.e., there are no two people
i and j who are not paired up, but would prefer to be
paired up rather than be paired with their current partner.
It may be that there is no such a stable pairing. This
LINGO model will find such a pairing if one exists, and
will minimize the worst that any person gets treated under
this pairing.

```

```
SETS:
```

```
PERSON: AP;
```

```
XPX(PERSON,PERSON): PEF, Y, R, NOSTAB;
```

```
ENDSETS
```

```
DATA:
```

```
! Example from Irving(1985);
```

```
PERSON = 1..8;
```

```
! Row preference for col;
```

```
PREF=!1 2 3 4 5 6 7 8;
```

```
99 1 7 3 2 4 5 6
```

```
3 99 1 7 6 2 4 5
```

```
7 3 99 1 5 6 2 4
```

```
1 7 3 99 4 5 6 2
```

```
2 4 5 6 99 1 7 3
```

```
6 2 4 5 3 99 1 7
```

```
5 6 2 4 7 3 99 1
```

```
4 5 6 2 1 6 3 99;
```

```
! E.g., the first choice of 1 is 2. The first choice
of 8 is 5.
```

```
! The 99 is to indicate that a person cannot be
matched to himself.
```

```
! This data set has 3 stable matchings;
```

```
ENDDATA
```

```
!  $Y(i,j) = 1$  if PERSON  $i$  and  $j$  are matched, for  $i < j$ ;
```

```
NP = @SIZE(PERSON);
```

```
! Each person must be assigned;
```

```
@FOR(PERSON(i):
```

```
@SUM(PERSON(k) | k #GT# i: Y(i,k))
```

```
+ @SUM(PERSON(k) | k #LT# i: Y(k,i)) = 1;
```

```
);
```

```
! Turn off the lower diagonal part of Y;
```

```
@SUM(PXP(i,j) | i #GT# j: Y(i,j)) = 0;
```

```
! Enforce monogamy by making the  $Y(i,j) = 0$  or 1;
```

```
@FOR(PXP(i,j):
```

```
@BIN(Y(i,j))
```

```
);
```

```
! Stability conditions: Either person  $i$  and person  $j$ 
are assigned to each other, or
```

```

    person i gets a person k he prefers to j, or
    person j gets a person k he prefers to i, or
    there is no stable solution;
@FOR( PXP(i,j) | i #LT# j:
    Y(i,j)
    + @SUM( PERSON(k) | k #LT# i #AND# PEF(i,k) #LT# PEF(i,j):
Y(k,i))
    + @SUM( PERSON(k) | k #GT# i #AND# PEF(i,k) #LT# PEF(i,j):
Y(i,k))
    + @SUM( PERSON(k) | k #LT# j #AND# PEF(j,k) #LT# PEF(j,i):
Y(k,j))
    + @SUM( PERSON(k) | k #GT# j #AND# PEF(j,k) #LT# PEF(j,i):
Y(j,k))
    + NOSTAB(i,j) >= 1
    );

! Compute actual assigned rank for each person;
@FOR( PERSON(i):
    AP(i) = @SUM( PERSON(k) | i #LT# k: PEF(i,k)*Y(i,k))
    + @SUM( PERSON(k) | k #LT# i: PEF(i,k)*Y(k,i));
    PWORST >= AP(i);
    );

! Compute number of instabilities;
NUMUSTAB = @SUM(PXP(i,j): NOSTAB(i,j));
! Apply most weight to getting a stable solution;
MIN = NP*NP*NUMUSTAB + PWORST;

```

Notice in the resulting solution below, there is a stable matching, i.e. NUMUSTAB = 0, and, no participant received worse than his second choice.

Variable	Value
NUMUSTAB	0.000000
Y(1, 5)	1.000000
Y(2, 6)	1.000000
Y(3, 7)	1.000000
Y(4, 8)	1.000000

16.6 Problems

1. Both Big Blue, Inc. and Golden Apple, Inc. are “market oriented” companies and feel market share is everything. The two of them have 100% of the market for a certain industrial product. Blue and Gold are now planning the marketing campaigns for the upcoming selling season. Each company has three alternative marketing strategies available for the season. Gold’s market share as a function of both the Blue and Gold decisions are tabulated below:

Payment To Blue by Gold as a Function of Both Decisions

		Blue Decision		
		A	B	C
Gold Decision	X	.4	.8	.6
	Y	.3	.7	.4
	Z	.5	.9	.5

Both Blue and Gold know the above matrix applies. Each must make their decision before learning the decision of the other. There are no other considerations.

- What decision do you recommend for Gold?
 - What decision do you recommend for Blue?
2. Formulate an LP for finding the optimal policies for Blue and Gold when confronted with the following game:

Payment To Blue By Gold as a Function of Both Decisions

		Blue Decision			
		A	B	C	D
Gold Decision	X	2	-2	1	6
	Y	-1	4	5	-1

3. Two competing manufacturing firms are contemplating their advertising options for the upcoming season. The profits for each firm as a function of the actions of both firms are shown below. Both firms know this table:

Profit Contributions

		Fulcher Fasteners		
		Option A	Option B	Option C
Repicky Rivets	Option Y	4	8	6
	Option X	10	4	6
		8	12	10
		8	2	4

- Which pair of actions is most profitable for the pair?
- Which pairs of actions are stable?
- Presuming side payments are legal, how much would which firm have to pay the other firm in order to convince them to stick with the most profitable pair of actions?

4. The three neighboring communities of Parched, Cactus and Tombstone are located in the desert and are analyzing their options for improving their water supplies. An aqueduct to the mountains would satisfy all their needs and cost in total \$730,000. Alternatively, Parched and Cactus could dig and share an artesian well of sufficient capacity, which would cost \$580,000. A similar option for Cactus and Tombstone would cost \$500,000. Parched, Cactus and Tombstone could each individually distribute shallow wells over their respective surface areas to satisfy their needs for respective costs of \$300,000, \$350,000 and \$250,000.

Formulate and solve a simple LP for finding a plausible way of allocating the \$730,000 cost of an aqueduct among the three communities.

5. Sportcasters say Team I is out of the running if the number of games already won by I plus the number of remaining games for Team I is less than the games already won by the league leader. It is frequently the case that a team is mathematically out of the running even before that point is reached. By Team I being mathematically out of the running, we mean there is no combination of wins and losses for the remaining games in the season such that Team I could end the season having won more games than any other team. A third-place team might find itself mathematically though not obviously out of the running if the first and second place teams have all their remaining games against each other.

Formulate a linear program that will not have a feasible solution if Team I is no longer in the running.

The following variables may be of interest:

x_{jk} = number of times Team j may beat Team k in the season's remaining games and Team I still win more games than anyone else.

The following constants should be used:

R_{jk} = number of remaining games between Team j and Team k . Note the number of times j beats k plus the number of times k beats j must equal R_{jk} .

T_k = total number of games won by Team k to date. Thus, the number of games won at season's end by Team k is T_k plus the number of times it beat other teams.

6. In the 1983 NBA basketball draft, two teams were tied for having the first draft pick, the reason being that they had equally dismal records the previous year. The tie was resolved by two flips of a coin. Houston was given the opportunity to call the first flip. Houston called it correctly and therefore was eligible to call the second flip. Houston also called the second flip correctly and thereby won the right to negotiate with the top-ranked college star, Ralph Sampson. Suppose you are in a similar two-flip situation. You suspect the special coin used may be biased, but you have no idea which way. If you are given the opportunity to call the first flip, should you definitely accept, be indifferent, or definitely reject the opportunity (and let the other team call the first flip). State your assumptions explicitly.
7. A recent auction for a farm described it as consisting of two tracts as follows:
- Tract 1: 40 acres, all tillable, good drainage.
Tract 2: 35 acres, of which 30 acres are tillable, 5 acres containing pasture, drainage ditch and small pond.

The format of the auction was described as follows. First Tract 1 and Tract 2 will each be auctioned individually. Upon completion of bidding on Tract 1 and Tract 2, there will be a 15 minute intermission. After that period of time, this property will be put together as one tract of farmland. There will be a premium added to the total dollar price of Tract 1 and Tract 2. This total dollar amount will be the starting price of the 75 acres. If, at that time, no one bids, then the property will go to the highest bidders on Tracts 1 and 2. Otherwise, if the bid increases, then it will be sold as one.

Can you think of some modest changes in the auction procedure that might increase the total amount received for the seller? What are some of the game theory issues facing the individual bidders in this case?

17

Inventory, Production, and Supply Chain Management

17.1 Introduction

One carries inventory for a variety of reasons:

- a) protect against uncertainty in demand,
- b) avoid high overhead costs associated with ordering or producing small quantities frequently,
- c) supply does not occur when demand occurs, even though both are predictable (e.g., seasonal products such as agricultural products, or anti-freeze)
- d) protect against uncertainty in supply,
- e) unavoidable “pipeline” inventories resulting from long transportation times (e.g., shipment of oil by pipeline, or grain by barge)
- f) for speculative reasons because of an expected price rise.

We will illustrate models useful for choosing appropriate inventory levels for situations (a), (b), (c) and (d).

17.2 One Period News Vendor Problem

For highly seasonal products, such as ski parkas, the catalog merchant, L. L. Bean makes an estimate for the upcoming season, of the mean and standard deviation of the demand for each type of parka. Because of the short length of the season, L.L. Bean has to make the decision of how much to produce of each parka type before it sees any of the demand. There are many other products for which essentially the same decision process applies, for example, newspapers, Christmas trees, anti-freeze, and road salt. This kind of problem is sometimes known as the one-period newsvendor problem.

To analyze the problem, we need the following data:

c = purchase cost/unit.

v = revenue per unit sold.

h = holding cost/unit purchased, but not sold. It may be negative if leftovers have a positive salvage value.

p = explicit penalty per unit of unsatisfied demand, beyond the lost revenue.

In addition, we need some information about the demand distribution (e.g., its mean and standard deviation). For the general case, we will presume for any value x :

$F(x)$ = probability demand (D) is less-than-or-equal-to x .

17.2.1 Analysis of the Decision

We want to choose:

S = the stock-up-to level (i.e., the amount to stock in anticipation of demand).

We can determine the best value for S by marginal analysis as follows. Suppose we are about to produce S units, but we ask, "What is the expected marginal value of producing one more unit?" It is:

$$\begin{aligned} & -c + (v+p) * \text{Prob}\{\text{demand} > S\} - h * \text{Prob}\{\text{demand} \leq S\} \\ & = -c + (v+p) * (1 - F(S)) - h * F(S) \\ & = -c + v + p - (v+p+h) * F(S). \end{aligned}$$

If this expression is positive, then it is worthwhile to increase S by at least one unit. In general, if this expression is zero, then the current value of S is optimal. Thus, we are interested in the value of S for which:

$$-c + v + p - (v+p+h) * F(S) = 0$$

or re-arranging:

$$\begin{aligned} F(S) & = (v+p-c) / (v+p+h) \\ & = (v+p-c) / [(v+p-c) + (c+h)]. \end{aligned}$$

Rephrasing the last line in words:

Probability of not stocking out should = (opportunity shortage cost)/[(opportunity shortage cost) + (opportunity holding cost)].

This formula is sometimes known as the *news vendor formula*.

Example 1, News vendor with discrete demand distribution:

Suppose L.L. Bean can purchase or produce a parka for \$60, sell it for \$140 during the regular season, and sell any leftovers for \$40. Thus:

$$\begin{aligned} c & = 60, \\ v & = 140, \\ p & = 0, \\ h & = -40. \end{aligned}$$

The opportunity shortage cost is $140 - 60 = 80$, and the opportunity holding cost is $60 - 40 = 20$. Therefore, the newsvendor ratio is $80/(80 + 20) = 0.8$.

To determine S , we must know the demand distribution. First, suppose this is not a big selling parka and we have the distribution in tabular form as follows:

Demand, D :	2	3	4	5	6	7	8	9	11	12	13	14	15
Prob{demand= D }:	.04	.06	.09	.10	.11	.12	.10	.09	.09	.07	.06	.05	.02
Cumulative, $F()$:	.04	.10	.19	.29	.40	.52	.62	.71	.80	.87	.93	.98	1.0

Thus, we should stock $S = 11$ units.

Example 2, News vendor with Normal distribution:

Suppose we have the same cost structure as before, but this item has a forecasted demand of 1000 and standard deviation of 300. We will make the standard assumption demand is Normal distributed. We must find the number of standard deviations above the mean such that the “left tail” probability is 0.80. From a Normal table, we see this occurs at about $z = .84$. The general form for the stock-up-to point is:

$$\begin{aligned} S &= \text{mean} + (\text{standard deviation}) * z, \\ &= 1000 + 300 * .84 = 1252. \end{aligned}$$

It would be nice to know the expected amount of lost sales. The “linear loss function”, or $@PSL()$ in LINGO gives us this, specifically:

$$\begin{aligned} (\text{expected lost sales}) &= (\text{standard deviation}) * @PSL(z) \\ &= (\text{standard deviation}) * @PSL((S - \text{mean})/(\text{standard deviation})) \\ &= 300 * @PSL(.84) \\ &= 300 * .1120 = 33.6 \end{aligned}$$

Alternatively, if we are lazy, we can use LINGO to do all the computations for us with the following model:

```

MODEL:
  ! Newsboy inventory model(NUSBOYGN);
  ! Calculate: optimal order up to stock level, S,
  and re-order point, R, for a
  product with a normally distributed demand;
  DATA:
  MU = 1000; ! Mean demand;
  SD = 300; ! Standard deviation in demand;
  V = 140; ! Revenue/unit sold;
  C = 60; ! Cost/unit purchased;
  P = 0; ! Penalty/unit unsatisfied demand;
  H = -40; !Holding cost/unit left in inventory;
  K = 1000; ! Fixed cost of placing an order;
  ENDDATA
  !-----;
  ! Compute the newsvendor ratio;
  RATIO = ( P + V - C)/( P + V - C + C + H);
  ! Calculate the order up to point, S;
  @PSN( ZS ) = RATIO;
  @FREE( ZS);
  S = MU + SD * ZS;
  ! Compute expected profit of being there, PS;
  ! Note if D = demand, then profit is:
  V * D - V * MAX( 0, D-S) - C * S
  - P * MAX(0,D-S) - H * (S-D) - H*MAX(0,D-S);
  ! Taking expectations and collecting terms...;
  PS = V * MU - C * S - H * ( S - MU)
      - ( V + P + H) * SD* @PSL( ZS) ;
  ! Expected profit at reorder point should differ
  from expected profit at S by fixed order cost, K;
  PR = PS - K;

```

```

! Solve for ZR;
PR = V * MU - C* R - H * ( R - MU)
      - ( V + P + H ) * SD* @PSL( ZR) ;
@FREE( ZR);
ZR <= ZS; ! Do not want the way over solution;
! Finally, compute the re-order point;
ZR = ( R - MU) / SD;
END

```

A solution is:

Variable	Value
MU	1000.000
SD	300.0000
V	140.0000
C	60.00000
P	0.0000000
H	-40.00000
K	1000.000
RATIO	0.8000000
ZS	0.8416211
S	1252.486
PS	71601.14
PR	70601.14
R	1114.215
ZR	0.3807171

The above examples assume the distribution of demand is known. In fact, getting a good estimate of the demand distribution is probably the most challenging aspect of using the news vendor model. The sports clothing retailer, Sport Obermeyer, see Fisher and Raman (1996), derive a demand distribution by soliciting forecasts from six experts. The average of these forecasts is used as the mean of the demand distribution. The standard deviation in the six forecasts is multiplied by an empirically derived adjustment factor (e.g., 1.75) to obtain the standard deviation used in the model. L.L. Bean apparently uses a slightly different approach to estimate the demand distribution for some of its products. A single point estimate forecast for a product is provided by either a single expert, typically a “buyer”, or by a consensus forecast from a group. An estimate of the standard deviation is obtained by assuming the coefficient of variation (i.e., standard deviation/mean) remains constant from year to year. The forecast errors from previous years are retained, and thus the coefficient of variation over previous years can be calculated.

17.3 Multi-Stage News Vendor

Advertisements for Lands End Outlet stores typically stress that items being sold in these stores are being sold at a very low price because they are left over from a catalog. Lands End stocked more units than catalog customers were interested in buying. The suggestion is that store customers can benefit from the poor inventory management of the catalog operation.

Similar examples are items carried in a “Christmas” catalog, then offered at a lower price in a “White” sale after the Christmas selling season, and perhaps offered at an even lower price at a third selling opportunity, if there are units still left in stock after the “White” sale. For example, a men’s long sleeve plaid shirt that was listed for \$36 in a recent L.L. Bean Spring catalog, was listed for \$25 in the subsequent Summer Sale catalog. Such multi-level selling situations are here referred to as multi-stage newsvendor problems.

When making the initial stocking decision, one should take into account the selling price and likely demand at each of the downstream levels. It is, in fact, relatively easy to do a fairly accurate analysis of the optimum amount to stock.

For example, suppose a retailer can purchase a particular type of coat from a supplier for \$100. The retailer will offer the garment for sale in the fall selling season for \$225. Any units left over from the fall selling season will be offered in the winter catalog for \$135. Any units still left over at that point will be offered for sale in “outlet” stores for \$95. Demands at the three levels are estimated to have means and standard deviations of:

Label:	Fall	Winter catalog	Outlet store
Mean	1200	300	400
Std.	500	150	190

Intuitively, it seems one should stock about $1200 + 300 = 1500$ units because it is profitable to sell the items in the winter catalog at \$135. However, sales in the outlet store are not profitable in retrospect. Can we do a little better than intuition?

Marginal analysis can be used quite nicely in this situation. It goes like this. We are contemplating stocking S units (e.g., 1400 units). Is it, in fact, worthwhile to increase our stocking level to $S+1$? If yes, we simply repeat until the answer is “no”. Let:

D_i = the (not yet seen) demand at stage i , for $i = 1, 2, 3$;
 v_i = the revenue or selling price/unit at level i ; and
 c = cost/unit.

The expected value of stocking one more unit in the general case is:

$$-c + v_3 * \text{Prob}\{D_1 + D_2 + D_3 > S\} + (v_2 - v_3) * \text{Prob}\{D_1 + D_2 > S\} + (v_1 - v_2) * \text{Prob}\{D_1 > S\}.$$

or in our specific example:

$$-100 + 95 * \text{Prob}\{D_1 + D_2 + D_3 > 1400\} + 40 * \text{Prob}\{D_1 + D_2 > 1400\} + 90 * \text{Prob}\{D_1 > 1400\}.$$

The reasoning behind this expression is as follows:

Stocking the additional item costs \$100.

If the total demand over the three levels is $> S$, then we clearly can sell the unit for at least \$95.

If the total demand over the first two levels is $> S$, then we will receive not just \$95, but an additional $135 - 95 = \$40$.

If the total demand in the first level is $> S$, we will receive not just \$135, but an additional $225 - 135 = \$90$.

At the optimum, this marginal cost expression should be essentially zero.

If we can assume the demands are Normally distributed at the three levels, then we can compute the expected value of carrying one more unit, and in fact solve for the optimum amount to stock. Note, we do not have to assume the demands are independent at the three levels. The analysis is still correct:

```

MODEL:
  ! Multi-echelon newsboy(MELNUBOY);
  ! Compute stock to carry, S;
  DATA:
  ! The cost/unit of the item;
  C = 100;
  ! Selling price/unit at the first level;
  V1 = 225;
  ! Selling price/unit at the second level;
  V2 = 135;
  ! Selling price/unit at the third level;
  V3 = 95;
  ! Mean demands at the three levels;
  MEAN1 = 1200;
  MEAN2 = 300;
  MEAN3 = 400;
  ! Standard deviations at the three levels;
  SD1 = 500;
  SD2 = 150;
  SD3 = 190;
  ENDDATA
  !-----;
  ! Compute means and s.d. of cumulative demands;
  CUMD3 = MEAN1 + MEAN2 + MEAN3;
  CUMD2 = MEAN1 + MEAN2;
  ! This assumes demands are independent;
  CUMSD3 = (SD1 * SD1 + SD2 * SD2 + SD3 * SD3)^.5;
  CUMSD2 = (SD1 * SD1 + SD2 * SD2)^.5;
  ! Compute S;
  ! Set to 0 marginal expected value of ordering
  one more unit beyond S, assuming Normal demand.;
  0 = - C
  +      V3 * ( 1 - @PSN(( S - CUMD3)/ CUMSD3))
  + ( V2 - V3) * ( 1 - @PSN(( S - CUMD2)/ CUMSD2))
  + ( V1 - V2) * ( 1 - @PSN(( S - MEAN1)/ SD1));
  ! Compute expected profit;
  !If the demands are D1, D2, and D3, then profit =
  V3* (( D1 + D2 + D3) - MAX( 0, D1+ D2+ D3 - S))
  +( V2 - V3) * (( D1 + D2)- MAX( 0, D1+ D2 - S))
  + ( V1 - V2) * ( D1 - MAX( 0, D1 - S))
  - C * S;
  ! Taking expectations;
  EPROFIT =
  V3 * (CUMD3- CUMSD3* @PSL(( S- CUMD3)/ CUMSD3))
  +(V2- V3)* (CUMD2 -CUMSD2*@PSL((S-CUMD2)/CUMSD2))
  +(V1- V2)* (MEAN1- SD1* @PSL((S- MEAN1)/ SD1))
  - C * S;
END

```

A solution is:

Variable	Value
C	100.0000
V1	225.0000
V2	135.0000
V3	95.00000
MEAN1	1200.000
MEAN2	300.0000
MEAN3	400.0000
SD1	500.0000
SD2	150.0000
SD3	190.0000
CUMD3	1900.000
CUMD2	1500.000
CUMSD3	555.5178
CUMSD2	522.0153
S	1621.628
EPROFIT	138339.6

We see that we should stock substantially more than 1500. Namely, about 1622 units.

17.3.1 Ordering with a Backup Option

One type of “supply chain” agreement used by a number of clothing suppliers (e.g., Liz Claiborne, Ann Klein, and Benetton) is the “backup” supply agreement. A typical agreement is characterized by two numbers, a backup or holdback fraction and a nonuse penalty. Under, say a (.2, .1) backup agreement, a store that orders 100 units of an item from Anne Klein must take delivery of $(1 - .2) \times 100 = 80$ units before the selling season begins. That is, the supplier holds back 20% of the order. During the selling season, the store may additionally request quick delivery on up to $.2 \times 100 = 20$ units at the same price. The store pays a penalty of $.1 \times (\text{purchase cost})$ for each item in the backup for which it does not request delivery. Essentially, the store requests delivery on additional backup items only when it is 100% sure of being able to sell the additional items.

Suppose your store is contemplating a (.2, .1) agreement for a particular item from Anne Klein that has a purchase cost of \$50 per unit. You sell it for \$160. You were planning to order 100 units of this item. Thus, you will definitely receive 80 and can sell up to 100 if the demand occurs. For any units of the 100 for which you do not take delivery, you must pay $.1 \times \$50 = \5 . You are now having second thoughts and want to know the marginal value of ordering one more unit of this item.

So, for example, if total demand is greater than the 100, then increasing order size by one is a smart move ($\$160 - \50). If the demand is less-than-or-equal-to 100, but greater than 80, it is not so smart ($-.1 \times \$50$). If demand is less-than-or-equal-to 80, then it is a dumb move (about $-\$50$, ouch!).

Marginal analysis can be used to determine the best initial order size. We will, in this case, assume any items left over are worthless. Define:

- c = cost/unit from the supplier,
- v = selling price/unit,
- b = holdback fraction,
- u = penalty/unit of unused holdback items, stated as a fraction of c ,
- h = holding cost/unit left over,
- D = the (random) demand.

The expected value of ordering one more unit beyond S is:

$$\begin{aligned} & (v - c) * \text{Prob} \{D > S\} \\ & - u * c * \text{Prob} \{S * (1 - b) < D \leq S\} \\ & - (c * (1 - b) + u * c * b + h(1 - b)) * \text{Prob} \{D \leq S * (1 - b)\} \end{aligned}$$

If this expression is positive, S should be increased. At the optimal S , the above expression should be approximately zero. The reasoning behind the three terms is:

If $D > S$, we will take delivery of all units ordered and make a profit of $v - c$ on the extra item ordered.

If $S * (1 - b) < D \leq S$, with or without the extra unit, we take delivery of D units. We have to pay a penalty of $u * c$ on the extra unit ordered, but not delivered.

If $D \leq S * (1 - b)$, we must take delivery of $(1 - b)$ additional units, for which we pay c and incur a holding cost h . We must pay a penalty $u * c$ on the additional units b on which we did not take delivery.

For our example data, suppose D has a Normal distribution with mean 400 and standard deviation 100. The following is a LINGO model for this case:

```
MODEL
! Newsboy with a holdback fraction(NUBOYBCK);
DATA:
! Cost/unit;
C = 50;
! Selling price/unit;
V = 160;
! Cost per item left over( <0 for salvage);
H = - 6;
! Holdback fraction;
B = .2;
! Fraction of cost paid on unused units;
U = .1;
! Mean demand;
MEAN = 400;
! Standard deviation in demand;
SD = 100;
ENDDATA
!Set to zero the marginal value of ordering an
additional unit beyond S;
( V - C) * ( 1 - @PSN(( S - MEAN)/ SD))
- U * C * ( @PSN(( S - MEAN)/ SD)
- @PSN(( S*( 1 - B) - MEAN)/ SD))
- (( C + H) * ( 1 - B) + U * C * B )
* @PSN(( S * ( 1 - B) - MEAN)/ SD) = 0;
END
```

A solution is:

Variable	Value
C	50.00000
V	160.0000
H	-6.000000
B	0.2000000
U	0.1000000
MEAN	400.0000
SD	100.0000
S	493.9043

The optimal order quantity is $S = 494$. This means we will take delivery of $0.8 \times 494 = 395$ units, and have the option to receive 99 more if needed.

17.3.2 Safety Lotsize

In the News vendor problem, we have to choose a number (e.g., S above) to try to match a random variable (e.g., the demand). A problem that is closely related to the newsvendor problem is the safety lotsize problem. The essential difference is that in the safety lotsize problem, we are given a target number, and we want to choose a distribution, so the associated random variable matches the given target number. The given number is typically a capacity, such as number of seats available on an aircraft, or parking spots in a garage, or the number of units of some product ordered by a customer. In each of these three cases, we may not be able to precisely control how many people show up for a flight, or control how many of the units we put into production turn out to be acceptable. For example, in the manufacture of semiconductor chips, the fraction of acceptable chips in a batch in the early stages of production may be as low as 20%. For airlines, a “no-show” rate of 15% is not unusual. We can, however, affect the number of “good outcomes” by such actions as how many reservations we give out for a flight or a parking lot, or how many chips we start into production. In semi-conductor chip manufacturing, even after considerable production experience is obtained, the yield may still be under 80%.

The following illustrates for the case of the so-called overbooking problem in the airlines. This model does the analysis for three different assumptions about the distribution of the number of customers that do not show up: the Normal distribution, the binomial, and the Poisson.

```

MODEL:
! Safety lot size/ Over booking model(SLOTSIZE);
! Compute S = number reservations to make;
! Keywords: overbooking, safety lotsize, lotsize;
DATA:
! Capacity, e.g., seats available;
M = 140;
! Prob{ unit is bad or no-show};
Q = .1;
! Cost per unit put in production;
C = - 188;
! Penalty per good unit short of target;
P = 0;
! Holding cost per good unit over target;
H = 420;

```

```

ENDDATA
!-----;
! Model: Define PROB =;
! Prob{ Bads <= S - M} = Prob{ Goods >= M};
! The marginal cost of ordering S+1 rather than S is:
  C - ( 1 - Q) * ( P * ( 1 - PROB) - H * PROB) = 0;
! Setting to zero, gives;
  PROB = ( P - C/( 1 - Q))/( P + H);
! Note: can also write as newsboy ratio:
  (P*(1-Q) - C)/(( P*(1-Q) - C) + (C + H*(1-Q)));
! Now determine units to put into production,
  reservations to sell, etc.;
! Binomial(Choose a sample of size SB, where,
  prob{unit is bad} = Q);
  PROB = @PBN( Q, SB, SB - M);
! Poisson approximation;
  PROB = @PPS( Q * SP, SP - M);
! Normal approximation. The .5 improves the
  approximation of the continuous Normal distribution
  to a discrete distribution. The variance of a
  binomial random variable is SN*Q*(1-Q);
  PROB =
    @PSN(( SN - M + .5 - Q * SN)/
      (( SN * Q * ( 1 - Q))^.5));
END

```

The solution is:

Variable	Value
M	140.0000
Q	0.1000000
C	-188.0000
P	0.0000000
H	420.0000
PROB	0.4973545
SB	154.8232
SP	154.7852
SN	154.9725

Thus, given that 10% of reservation holders do not show up and we have 140 seats to fill, regardless of our distribution assumption, we should sell 155 reservations (and hope exactly 140 customers show up).

17.3.3 Multiproduct Inventories with Substitution

One of the most important issues in inventory management is the consideration of unsatisfied demand, lost sales, or stockouts. When there are multiple related products, unsatisfied demand from one product may be satisfied by some other similar product. General Motors (see for example Eppen, Martin, and Schrage (1989)) has historically used a “diversion matrix” to represent the rate at which unsatisfied demand for one kind of GM car gets satisfied by, or substituted for, some other car. Similar methods have been used in the airlines in choosing capacities for various flights during the day. Here the process may be referred to as “spill” and “recapture”. The problem also arises in planning vehicle

fleets in the face of uncertain demand for vehicles of various sizes and types. If there is a shortage of small vehicles on a given day, surplus large vehicles may be substituted for the small.

The model below illustrates the essential aspects of the demand diversion inventory model used in the aforementioned GM study. The model is a one-period newsvendor type model, except there are multiple products. Each product has a cost per unit for each unit stocked, a revenue per unit for each unit sold, and a holding cost per unit left over. If there are n products, then shortage costs and the interaction among products is modeled by:

- an n by n diversion matrix that specifies what fraction of the unsatisfied demand of product i may be diverted to and satisfied by product j , and
- an n by n transfer cost matrix that specifies the cost per unit of transferring demand from one product to another.

For example, if a coach class passenger gets upgraded to first class because of lack of space in coach, one can represent this as a sale of a first class seat with the transfer cost being the difference in cost between a first class seat and a coach class seat. This model represents demands by scenarios. Each scenario specifies the demand for all products for that scenario. It is generally convenient to have a $n+1^{\text{st}}$ product class that represents the outside world. Demand transferred to it is truly lost.

Example

Multisys, Inc. provides maintenance under contract of desktop computers to industrial firms. Multisys, has just received notice from its disk supplier that it is about to make its last production run for 1 Gig and 2 Gig disk drives. These drives are becoming obsolete as larger capacity drives are becoming available. Multisys still has a large number of computers under maintenance contract that have these 1 and 2 Gig drives. The two drives are plug-compatible physically (i.e., they are the same size and have the same electrical connections). About one third of the computers under contract that have the 1 Gig drive are software incompatible with the 2 Gig drive in that they cannot access or otherwise function with a disk with more than 1 Gig of storage. Otherwise, a 2 Gig drive could be substituted for a 1 Gig drive, and a customer receiving such a substitution would be happy. The 2 Gig drive costs more to Multisys, \$200, vs. \$140 for the 1 Gig drive. When Multisys replaces a drive, it charges a customer a service charge of either \$20 or \$30 depending upon whether the original disk is a 1 Gig or a 2 Gig disk. Multisys has enumerated a half dozen scenarios of what its customer requirements might be for replacement disks in the remaining life of their contracts (see the scenarios in the model). If Multisys is short of disks, it will have to buy them on the open retail market, where it expects it would have to pay \$190 and \$250 respectively for the 1 Gig and 2 Gig drives. Any drive left over after all maintenance contracts have expired is expected to have a salvage value of about \$30, regardless of size. How many of each drive should Multisys order from its supplier?

For this problem, the scenario approach introduced in chapter 12 is very convenient. We identify a number of scenarios of what the demands could be. This allows one to have rather arbitrary demand distributions. In particular, demands among the products can be correlated, as is frequently the case in reality. In the example below, we identify a modest six demand scenarios:

```

MODEL:
! Multi-product Newsboy inventory model(NUSBOYML),
  with substitution, diversion, or spill.
For each product,
  calculate the optimal order up to stock level, S;
SETS:
  PROD/ G1 G2 SPOT/: C, V, H, S;
  PXP( PROD, PROD): FRAC, TC;
  SCEN/1..6/: PROB, PROF;
  SXP( SCEN, PROD): DEM, U, I;
  SXPXP( SCEN, PROD, PROD): T;
ENDSETS
DATA:
! Cost data for 1 Gig and 2 Gig disk drives.
  Third product is outside spot market;
V = 20 30 0; ! Revenue/unit sold;
C = 140 200 0; ! Cost/unit stocked;
H = -30 -30 0; ! Holding cost/unit unused;
! The diversion matrix. FRAC( PR, PX) = upper limit
  on fraction of product PX unsatisfied demand that
  can be satisfied by product PR;
FRAC =
  1 0 0 ! Upper limits on;
  .66667 1 0 ! substitution fractions;
  1 1 1; ! Sum over col should be >= 1;
! Transfer costs. TC( PR, PX) = cost per unit of
  satisfying a type PX demand with a type PR product;
TC =
  0 0 0 ! Cost of transferring;
  0 0 0 ! or substituting one;
  190 250 0; ! product for another;
! The demand scenarios. 3rd product takes care of
  unsatisfied demand;
DEM = 2100 3300 0
      900 2710 0
      1890 2256 0
      1994 1840 0
      2442 2334 0
      1509 2654 0;
! Prob of each scenario;
! (They are equally likely);
PROB = .166667 .166667 .166667
       .166667 .166667 .166667;
ENDDATA

```

```

!-----;
! Maximize expected profit;
MAX = @SUM( SCEN( SC): PROB( SC) * PROF( SC));
! For each scenario;
@FOR( SCEN( SC):
  ! profit =
    revenues - acquisition cost
    - holding cost - transfer costs;
! T( SC, PR, PX) = units of type PX demand satisfied
  by a type PR product;
  PROF( SC) =
    @SUM( PROD( PR):
      V( PR) * @SUM( PROD( PX): T( SC, PX, PR))
      - C( PR) * S( PR)
      - H( PR) * I( SC, PR)
      - @SUM( PROD( PX):
        TC( PR, PX) * T( SC, PR, PX));
    @FREE( PROF( SC));
  @FOR( PROD( PR):
! Stock = inventory left + sent to various products;
  S( PR) = I( SC, PR) + @SUM( PROD( PX):
    T( SC, PR, PX));
! Directly satisfied + unsatisfied = original demand;
  T( SC, PR, PR) + U( SC, PR) = DEM( SC, PR);
! Unsatisfied demand must be covered from somewhere;
  U( SC, PR) = @SUM( PROD( PX)| PX #NE# PR:
    T( SC, PX, PR));
! Cannot send too much to any one place;
  @FOR( PROD( PX)| PX #NE# PR:
    T( SC, PX, PR) <= FRAC( PX, PR) * U( SC, PR);
! In case users find it confusing
  to transfer fractional items;
  @GIN( T( SC, PR, PX));
  );
  );
  );
END

```

When solved, we see the expected net cost is \$694,806.4. Hopefully, the maintenance revenues to Multisys are higher than this:

Objective value: -694806.

We see Multisys should stock 1508 of the 1 Gig drives and 2334 of the 2 Gig drives. There is at least one scenario in which it must buy 1558 drives on the spot market:

Variable	Value
S(G1)	1508.000
S(G2)	2334.000
S(SPOT)	1558.000

It is interesting to look at the transfers required under each scenario:

T(1, G1, G1)	1508.000
T(1, G2, G2)	2334.000
T(1, SPOT, G1)	592.000
T(1, SPOT, G2)	966.000
T(2, G1, G1)	900.0000
T(2, G2, G2)	2334.000
T(2, SPOT, G2)	376.000
T(3, G1, G1)	1508.000
T(3, G2, G1)	78.000
T(3, G2, G2)	2256.000
T(3, SPOT, G1)	304.000
T(4, G1, G1)	1508.000
T(4, G2, G1)	324.000
T(4, G2, G2)	1840.000
T(4, SPOT, G1)	162.000
T(5, G1, G1)	1508.000
T(5, G2, G2)	2334.000
T(5, SPOT, G1)	934.000
T(6, G1, G1)	1508.000
T(6, G2, G2)	2334.000
T(6, SPOT, G1)	1.000
T(6, SPOT, G2)	320.000

Notice Multisys plans to go to the spot market under every scenario. In scenarios 3 and 4, surplus 2 Gig drives are substituted for 1 Gig drives.

17.4 Economic Order Quantity

The EOQ model assumes demand is constant over time and any order is satisfied instantly. Define:

D = demand/year,
 K = fixed cost of placing an order,
 H = holding cost per unit per year.

We want to determine:

Q = quantity to order each time we order.

For any Q chosen, the sum of setup and holding costs is:

$$K * D / Q + h * Q / 2.$$

The minimum of this function occurs when we set:

$$Q = (2 * K * D / h)^{0.5}$$

If we substitute this value for Q back into the cost function, we can find the cost per year if we behave optimally is:

$$(2 * K * D * h)^{0.5}$$

This cost expression illustrates an interesting economy of scale in inventory management with respect to demand volume, D .

Inventory related costs increase with the square root of volume. Thus, if you have two independent facilities, each incurring \$1M per year in inventory related costs, combining them into a single facility will reduce total system costs to \$1.41 M from the original \$2M.

17.5 The Q,r Model

The Q,r model extends the EOQ model with the additional realistic assumptions:

- a) there is a positive lead time, and
- b) the demand during the lead time is random.

If not for (b), we could trivially extend the EOQ model with the simple observation that we should place our order for the amount Q each time the inventory drops to r = demand during a lead time. Thus, each order will arrive just as inventory hits zero.

If the demand during a lead-time is random, then we will typically wish to increase r slightly to reduce the probability of running out before the order arrives. The Q,r policy is fairly common. For example, Dick Dauch, as Executive Vice President of Worldwide Manufacturing at Chrysler (see Dauch (1993)), used a slight variant of the Q,r model on a wide range of products at Chrysler. Nahmias (1997) gives a thorough introduction to the Q,r model.

17.5.1 Distribution of Lead Time Demand

Define:

- L = mean lead time in years,
- D = mean demand / year,
- sd_L = standard deviation in lead time,
- sd_D = standard deviation in demand / year,
- $MLD = L * D$ = mean lead time demand.

If demands from one period to the next are independent and identically distributed, then the standard deviation in demand during a lead time, sd_o , is given by:

$$sd_o = (L * sd_D^2 + D * D * sd_L^2)^{0.5}$$

This formula assumes demands, or forecast errors, are independently distributed among periods. In reality, demands (or at least forecast errors) tend to be positively correlated among periods. The result is this formula will typically understate the true standard deviation in lead-time demand or forecast error over the lead-time.

17.5.2 Cost Analysis of Q,r

Define:

- $F(r)$ = probability we do not run short in an order cycle if the reorder point is r ,
- $b(r)$ = expected number of units short in an order cycle if the reorder point is r .

If it is safe to assume lead-time demand has a Normal distribution, then:

$$b(r) = sd_o * @PSL((r - MLD) / sd_o).$$

For a given Q , and r , the approximate expected cost per year is:

$$K * (\text{number of orders per year}) + h * (\text{average inventory level}) + p * b(r) * (\text{number of orders per year})$$

The average inventory level can be approximated as follows. On average, the stock level expected at the end of an order cycle (just before an order comes in) is:

$$r - MLD + b(r).$$

The $b(r)$ term is effectively a correction for the fact that $r - MLD$ by itself would be an average over situations, some of which correspond to negative inventory. When inventory is negative, we should not be charging the holding cost h to it (thereby claiming an income rather than a cost). The $b(r)$ term effectively adds back in the negative inventory that would occur when the lead-time demand is greater than r .

When the replenishment order arrives, the stock level is the order quantity Q plus the average quantity in stock at the end of the previous cycle ($r - MLD + b(r)$). The average stock level is the average of these two quantities, $[Q + (r - MLD + b(r)) + (r - MLD + b(r))]/2 = (Q/2 + r - MLD + b(r))$. Note $r - MLD + b(r)$ is the average safety stock in the system.

So, we can write the average cost per year as:

$$= K * D/Q + h * (Q/2 + r - MLD + b(r)) + p * b(r) * D / Q$$

or

$$= (K + p * b(r)) * D / Q + h * (Q/2 + r - MLD + b(r)).$$

This cost expression does not contain a term for inventory in the pipeline (i.e., inventory ordered but not yet on hand). For a given lead time, the average pipeline inventory is a constant equal to $D * L = MLD$. A different holding cost rate may apply to pipeline inventory than to inventory on hand. There may be several reasons why the carrying cost of inventory on order is less than the carrying cost of physical inventory. For example, in the auto industry, a lead time of ten weeks is not unusual for the time from when a dealer places an order with the manufacturer until the order arrives. Of these ten weeks, the first nine weeks might be manufacturing time with only the last week being the time to ship the automobile from the manufacturer to the dealer. The cars are typically shipped FOB (Free On Board/From Our Base) the manufacturer's plant. The dealer thus pays for the car once it ships. So, the dealer incurs inventory carrying costs (e.g., cost of capital, for only one tenth of the lead time).

To minimize the cost, we can either note the similarity of the cost expression to that of the simple EOQ model, or we can differentiate with respect to the parameters and set to zero to get:

$$Q = [2 * D * (K + p * b(r)) / h]^{0.5}, \text{ and}$$

$$1 - F(r) = h * Q / (h * Q + p * D), \text{ or}$$

$$F(r) = p * D / (p * D + h * Q).$$

Note the similarity of the above to the news vendor formula. The intuition is as follows. Suppose we increase the reorder point, r , by one unit. If demand is high during the lead time, then the shortage cost avoided is p . If demand is low, then we simply carried an extra unit in inventory for a cycle, incurring a cost of $h * (\text{cycle length}) = h * D/Q$. Using the newsvendor-like arguments, we want to set:

$$F(r) = p / (p + h * D/Q) = p * D / (p * D + h * Q).$$

Some textbooks, see Nahmias (1997) for a discussion, using a slightly different approximation to expected inventory level just before an order arrives, get a slightly different expression for $F(r)$, namely:

$$F(r) = (p * D - h * Q) / (p * D).$$

Both are the result of making approximations to the average inventory level. The latter is intuitively less appealing because, for high values of $h * Q$, it can result in a negative value for $F(r)$. Negative probabilities are hard to comprehend. When $h * Q$ is small relative to $p * D$, then the two expressions result in approximately the same value for $F(r)$. For example, if $p * D = 1.0$ and $h * Q = .05$, then:

$$1/1.05 = 0.952;$$

whereas:

$$(1 - .05) / 1 = 0.95.$$

Example

When Hewlett-Packard first started supplying printers to Europe, the shipping time from its plant on the west coast of the U.S. to Europe was about five weeks. Suppose the forecasted yearly demand for a certain printer was 270,000 units, with a monthly standard deviation of about 6351. A monthly standard deviation of 6351 implies a monthly variance of $6351 * 6351 = 40333333$, a yearly variance (if monthly demands are independent) of $12 * 40333333 = 484000000$, and a yearly standard deviation of $(484000000)^{.5} = 22000$. The yearly holding cost is \$110/printer per year. We allow a separate cost term for pipeline inventory of \$5/unit. For example, if we do not have to pay for a product until we receive it, then there would be no charge on pipeline inventory. The penalty for being out of stock when a demand occurs is \$200/printer. The fixed cost of placing an order is \$300. Suppose the standard deviation in lead-time is two weeks. What should be the re-order point and the re-order quantity? We can have LINGO do all the work for us with the following model:

```
! Q,r inventory model( EOQRMODL);
! Find the order quantity, Q,
  and re-order point, R, for a product with...;
DATA:
D = 270000; ! Mean demand / year;
H = 110; ! Holding cost/unit/year;
HP= 5; ! Holding cost on pipeline inventory;
K = 300; ! Fixed order cost;
P = 200; ! Penalty cost/ unsatisfied demand;
L = .0962; ! Lead time in years;
SDL = .03846; ! S.D. in lead time in years;
SDD = 22000; ! S.D. in yearly demand;
ENDDATA
!-----;
! The Q,R inventory model;
MLD = L * D; ! Mean lead time demand;
! s.d. in lead time demand;
SLD=(SDD * SDD * L + D * D * SDL * SDL)^.5;
! Expected cost/ period is ECOST;
MIN = ECOST;
ECOST = COSTORD + COSTCYC + COSTSFT + COSTPEN + COSTPIPE;
COSTORD = ( K * D / Q);
```

```

COSTCYC = H * Q/2;
COSTSFT = H*( R - MLD + BR);
COSTPEN = P * D * BR/ Q;
COSTPIPE = HP * MLD;
!Expected amount short/cycle. @PSL() is
  the standard Normal linear loss function;
BR = SLD * @PSL( Z);
!@PSN()is the standard Normal left tail prob.;
@PSN( Z) = P * D / ( P * D + H * Q);
R = MLD + SLD * Z;      ! Reorder point;
! The following are all to help solve it faster;
Q >= (2*K*D/H)^.5;
@BND( - 3, Z, 3);
@FREE( ECOST);      @FREE( R);
@FREE( COSTORD); @FREE( COSTCYC);
@FREE( COSTSFT); @FREE( COSTPEN);
@FREE( Z);          @FREE( BR);

```

Note it breaks the total cost into five components:

1. ordering costs due to the \$300 cost of placing an order,
2. cycle inventory due to carrying inventory between order points,
3. holding costs due to carrying safety stock,
4. penalty costs due to being out of stock, and
5. pipeline inventory costs due to product we have paid for, so-called FOB, but not yet received.

It will be interesting to see which of the five is the most significant. A solution is:

Variable	Value
D	270000.0
H	110.0
HP	5.0
K	300.0
P	200.0
L	0.0962
SDL	0.03846
SDD	22000.0
MLD	25974.0
SLD	12425.47
ECOST	3995220.0
COSTORD	8991.226
COSTCYC	495483.0
COSTSFT	2874377.0
COSTPEN	486498.0
COSTPIPE	129870.0
Q	9008.782
R	52023.54
BR	81.16215
Z	2.096463

Notice that, of the yearly cost of about \$3,995,220, the major component is the safety stock cost of \$2,874,377. Comparing the order quantity of 9008 with the yearly demand of 270,000, we can observe this corresponds essentially to ordering every 12 days. The high re-order point, 52,024, relative to the

order quantity is because of the long five-week delivery pipeline. Note, five weeks of demand is about 26,000 units.

This model can answer a variety of “what-if” questions regarding how cost is affected by various features of the supply chain. For example, suppose we could switch to a very reliable carrier, so the lead-time is always exactly five weeks. We simply set $SDL = 0$ in the data section as follows:

```
DATA:
D = 270000; ! Mean demand / year;
H = 110; ! Holding cost/unit/year;
HP= 5; ! Holding cost on pipeline inventory;
K = 300; ! Fixed order cost;
P = 200; ! Penalty cost/ unsatisfied demand;
L = .0962; ! Lead time in years;
SDL = 0.0; ! S.D. in lead time in years;
SDD = 22000; ! S.D. in yearly demand;
ENDDATA
```

And get the solution:

Variable	Value
D	270000.0
H	110.0
HP	5.0
K	300.0
P	200.0
L	0.0962
SDL	0.0
SDD	22000.0
MLD	25974.0
SLD	6823.547
ECOST	2419380.0
COSTORD	16623.32
COSTCYC	267997.1
COSTSFT	1753502.0
COSTPEN	251387.9
COSTPIPE	129870.0
Q	4872.674
R	41892.24
BR	22.68391
Z	2.33284

So, it looks like the uncertainty in the lead-time is costing us about $3995220 - 2419380 = \$1,575,840$ a year, most of it in extra safety stock.

We might push the lead time improvement further. Suppose by using airfreight, we could reduce the lead-time from 5 weeks to a reliable 1 week. Our transportation costs will be higher, but how much could we save in inventory related costs? We set $L = 1/52 = .01923$. Thus:

```
DATA:
  D = 270000; ! Mean demand / year;
  H = 110; ! Holding cost/unit/year;
  HP= 5; ! Holding cost on pipeline inventory;
  K = 300; ! Fixed order cost;
  P = 200; ! Penalty cost/ unsatisfied demand;
  L = .01923; ! Lead time in years;
  SDL = 0.0; ! S.D. in lead time in years;
  SDD = 22000; ! S.D. in yearly demand;
ENDDATA
```

Now, the solution is:

Variable	Value
D	270000.0
H	110.0000
HP	5.000000
K	300.0000
P	200.0000
L	0.0192300
SDL	0.0000000
SDD	22000.00
MLD	5192.100
SLD	3050.790
ECOST	1164946.
COSTORD	32286.60
COSTCYC	137982.9
COSTSFT	863009.1
COSTPEN	105707.1
COSTPIPE	25960.50
Q	2508.780
R	13032.73
BR	4.911033
Z	2.570031

This looks very promising. Total costs are cut to less than half. Most of the savings, about \$900,000, comes from a reduction in safety stock, about \$400,000 from reduction in pipeline inventory, and about \$100,000 savings each from a reduction in penalty costs and cycle or pipeline stock.

17.6 Base Stock Inventory Policy

If the fixed cost of placing an order is very low relative to the cost of carrying inventory and the cost of being out of stock, then the optimal policy is to reorder one unit whenever a demand occurs. From the Q, r model perspective, the optimal solution has $Q = 1$. Thus, the only decision is R , the reorder point. R is said to be the base stock. An order is placed every time the stock level drops below R . In other words, as soon as demand is observed. Clearly, such a model is interesting only when replenishment lead times are greater than zero. The main tradeoff in the system is between the cost of holding versus the expected cost of backorders or lost sales, just as in the news vendor problem. Base stock policies

are very common in aircraft maintenance systems, where spare parts, such as engines, are very valuable relative to the fixed cost of shipping a part to a location where it is needed. Periodic base stock policies are also used for many items in a grocery store. A typical product in a grocery store has a fixed amount of shelf space allocated to it. Early each day, a supplier will stop by the store and fill up the space. The major decision is how much space to allot to each item.

17.6.1 Base Stock — Periodic Review

A slight variation of the basic base stock system is one in which inventory is not checked at every instant, but only periodically. For example, if the product is supplied by ship and the ship arrives only every two weeks, then there is not much benefit in checking inventory constantly. The most typical review period might be weekly (e.g., on Monday mornings after big weekend demand in a retail store). The Newsvendor analysis can then be used to determine the best order-up-to level. Let:

$$\begin{aligned} L &= \text{lead time in periods,} \\ h &= \text{holding cost per unit left in stock at end of period,} \\ p &= \text{penalty per unit of demand not satisfied from inventory immediately,} \\ S &= \text{pipeline order up to level (also = the reorder point } R), \\ D_t &= \text{demand in period } t. \end{aligned}$$

We want to determine the best value for S , given known values for L , h , and p , with the D_t 's being random variables.

17.6.2 Policy

At the beginning of each period, we observe the pipeline inventory, y , and place an order for $S - y$. Thus, an order placed in period t arrives just before demand occurs in period $t + L$ (but after demand occurs in $t + L - 1$). So, $L = 0$ corresponds to instant delivery. We assume *unsatisfied demand is backlogged*.

17.6.3 Analysis

Just before demand occurs in period $t + L$, the physical inventory available to immediately satisfy demand is:

$$S - \sum_{j=t}^{t+L-1} D_j$$

(e.g., if $L = 0$, the physical inventory is simply S).

If the demands are randomly distributed, let:

$$F(x) = \text{Prob} \left\{ \sum_{j=t}^{t+L} D_j \leq x \right\}$$

Then, by marginal analysis, the expected profit contribution of increasing S by one unit is:

$$p(1 - F(S)) - h F(S).$$

Setting this to zero gives:

$$\begin{aligned} p &= (p + h)F(S) \\ \text{or} \\ F(S) &= p/(p + h) \end{aligned}$$

Note, we did not require the assumption that D_t be independently distributed.

The expected holding and shortage cost per period is:

$$E \left[h * \max \left(0, S - \sum_{j=t}^{t+L} D_j \right) + p * \max \left(0, \sum_{j=t}^{t+L} D_j - S \right) \right]$$

$$= E \left[h * \left(S - \sum_{j=t}^{t+L} D_j \right) + (p + h) * \max \left(0, \sum_{j=t}^{t+L} D_j - S \right) \right]$$

In the case that $\sum_{j=t}^{t+L} D_j$ is Normal with mean μ and s.d. σ , the expected holding and shortage cost can be written as:

$$= h(S - \mu) + (p + h) \sigma * @PSL((S - \mu) / \sigma).$$

The lost sales case is very difficult to analyze. The backlogging case as an approximation to the lost sales case will tend to set S too high, understate holding costs, and overstate shortage costs.

Example

An item at a food store is restocked daily. It has a mean demand of 18 units per day with a standard deviation of 4.243. There is a lead-time of two days before an order gets replenished. The holding cost per unit is \$0.005 per day. The shortage penalty per unit is \$0.05 per day.

```
! Base stock policy
with periodic review and Normal demand(BASESTP)
DATA:
H = .005; ! Holding cost/day;
P = .05; ! Shortage penalty/day;
MEAN = 18; ! Mean demand/day;
SD = 4.243;! Std. Dev. in demand/day;
LEADT = 2; !Lead time in days;
ENDDATA
!-----;
MU = LEADT * MEAN;
SIG = (LEADT * SD * SD)^.5;
MIN = H * ( S - MU) +
      ( H + P) * SIG * @PSL(( S - MU) / SIG);
```

The solution is:

```
Optimal solution found at step:          11
Objective value:                      0.5399486E-01
Variable      Value      Reduced Cost
H              0.5000000E-02      0.0000000
P              0.5000000E-01      0.0000000
MEAN           18.000000          0.0000000
SD              4.243000          0.0000000
LEADT          2.000000          0.0000000
MU              36.000000          0.0000000
SIG             6.000508          0.0000000
S              44.01758           0.8759009E-05
```

So, we should carry a base stock of 44 units and expect holding plus penalty costs to be about \$0.054 per day.

17.6.4 Base Stock — Continuous Review

We say we have continuous review if we review inventory continuously and place an order at any instant that the inventory level drops below the reorder point. Under continuous review, it is convenient to assume demand has a Poisson distribution. In fact, the Poisson distribution is a very appropriate distribution to use for slow moving items. A useful definition of a slow moving item is one for which the mean demand in a period is less than two times its standard deviation. Just as @PSL() is the linear loss function for the Normal distribution, @PPL() is the linear loss function for the Poisson distribution. Arguing much as before, the relevant model for the Poisson distribution is:

```
! Base stock policy
  with continuous review and Poisson demand(BASESTC);
DATA:
  H = .005; ! Holding cost/day;
  P = .05; ! Shortage penalty/day;
  MEAN = 18; ! Mean demand/day;
  LEADT = 2; !Lead time in days;
ENDDATA
!-----;
  MU = LEADT * MEAN;
  MIN = H * ( S - MU) + ( H + P) * @PPL( MU, S);
```

For this set of data, we get essentially the same result as when the Normal distribution was used:

```
Optimal solution found at step:          66
Objective value:                    0.5583237E-01
Variable          Value          Reduced Cost
  H              0.5000000E-02      0.0000000
  P              0.5000000E-01      0.0000000
  MEAN           18.00000          0.0000000
  LEADT          2.000000          0.0000000
  MU             36.00000          0.0000000
  S             43.99994          -0.4514980E-02
```

17.7 Multi-Echelon Base Stock, the METRIC Model

In 1997, the Wall Street Journal reported General Motors (GM) switched to a “distribution center” structure for distributing some of its automobile lines, see Stern and Blumenstein (1996). Previously, all of GM’s finished products were stored at retail car dealers. Under the new system, a significant fraction of cars would be stored at distribution centers (DC) located strategically around the country. Under the old system, if a given dealer did not have the exact style of car desired by a customer, then with high probability that dealer would lose the sale. Even worse for GM, that potential customer might switch to a competing manufacturer’s product.

Under the DC structure, a dealer would typically be able to get, within one day’s time from a nearby DC, the exact car desired by the customer. Under either system, GM must decide:

- 1) how much inventory to allocate to each dealer.

Under the DC system, GM must also decide:

- 2) how much inventory to allocate to each DC.

A very similar problem is faced by a large airline. In order to maintain high on-time service, an airline must be able to quickly replace any critical part that fails in an aircraft. For example, the author

once had to wait five hours to board a flight because a safety exit chute on the aircraft was accidentally deployed while the aircraft was at the gate. There was a five-hour delay while a replacement chute was flown in from 1500 kilometers away. An airline must decide which parts to stock at which locations around the country. Some high demand parts will be stocked at locations where the demand is likely to occur, and some parts will be stored at centrally located DC's, so they can be quickly flown to low demand cities when demand occurs there.

A key feature of many of these "inventory positioning" problems involving high value items is the appropriate replenishment policy to use as a base stock policy. That is, whenever a demand removes a unit from inventory, an order for a replacement unit is placed immediately. When there are two or more levels in the distribution system (e.g., retail outlets served by one or more DC's), the most widely used model for analyzing this inventory positioning problem is some variation of the METRIC model developed by Sherbrooke (1992) for managing spare parts inventories for the U.S. Air Force. The following model illustrates for the case of five outlets served by a single DC or "depot". In this version, the user specifies, among other parameters, how much stock to carry at the DC and how much stock to allocate over all outlets. The model decides how to best allocate the stock over the outlets and reports the total expected units on backorder.

We look at a situation of how to allocate five units of inventory, say spare engines for an airline, at either a central depot and at each of five demand points:

```

MODEL:
  ! Two level inventory model with possible
  repair at outlet (METRICX);
  ! Compute average units on backorder, TBACK, for
  given limit on depot stock and stock available
  for outlets, using a base stock policy;
SETS:
  OUTLET/1..5/: ! Each outlet has a...;
  D2OUTL, ! Resupply time from depot to outlet;
  DEM,    ! Demand rate at outlet;
  PREP,   ! Prob item can be repaired at outlet;
  REPT,   ! Repair time at outlet;
  SOUTLET, ! Stock level;
  ERT,    ! Effective resupply time from depot;
  AL;     ! Average level of backlogged demand;
ENDSETS
DATA:
  ! Delivery time to outlet from depot (days);
  D2OUTL = 3    7    3    3    9;
  ! Expected demand/day;
  DEM = .068 .05 .074 .063 .038;
  ! Probability item can be repaired at outlet;
  PREP= .2   .2   .2   .25  .1;
  ! Repair time at outlet, if repairable;
  REPT= 3    3    3    3    3;
  ! Stock levels to allocate over all outlets;
  SOUTOTL = 5; ! at the depot;
  SDEPOT = 0; ! Resupply time at depot;
  RDEPOT = 9;
  ENDDATA

```

```

!-----;
! Compute total demand at depot;
DEMO = @SUM( OUTLET: DEM * ( 1 - PREP));
! Effective expected wait at depot;
EWT0 = @PPL( DEMO * RDEPOT, SDEPOT)/ DEMO;
@FOR( OUTLET( I):
! Estimate resupply time including depot delay;
ERT( I) = D2OUTL( I) + EWT0;
! Expected demand on backorder;
AL( I) =
@PPL( DEM( I)* ( 1 - PREP( I)) * ERT( I)
+ DEM( I) * PREP( I) * REPT( I), SOUTLET( I));
! Can stock only integer quantities;
@GIN( SOUTLET( I));
);
! Total expected demand on backorder;
TBACK = @SUM( OUTLET: AL);
! Limit on stock at outlets;
@SUM( OUTLET( I): SOUTLET( I)) <= SOUTOTL;
! Minimize expected backorders;
MIN = TBACK;
END

```

Case 0: All inventory at outlets:

Variable	Value
SDEPOT	0.000000
SOUTLET(1)	1.000000
SOUTLET(2)	1.000000
SOUTLET(3)	1.000000
SOUTLET(4)	1.000000
SOUTLET(5)	1.000000
TBACK	.9166685
ERT(1)	12.00000
ERT(2)	16.00000
ERT(3)	12.00000
ERT(4)	12.00000
ERT(5)	18.00000

Case 1: One unit at the depot:

Variable	Value
SDEPOT	1.000000
SOUTLET(1)	1.000000
SOUTLET(2)	1.000000
SOUTLET(3)	1.000000
SOUTLET(4)	0.000000
SOUTLET(5)	1.000000
TBACK	.8813626
ERT(1)	8.258586
ERT(2)	12.25859
ERT(3)	8.258586
ERT(4)	8.258586
ERT(5)	14.25859

Case 2: Two units at the depot:

Variable	Value
SDEPOT	2.000000
SOUTLET(1)	0.000000
SOUTLET(2)	1.000000
SOUTLET(3)	1.000000
SOUTLET(4)	0.000000
SOUTLET(5)	1.000000
TBACK	.8683596
ERT(1)	5.602399
ERT(2)	9.602399
ERT(3)	5.602399
ERT(4)	5.602399
ERT(5)	11.60240

Case 3: Three units at the depot:

Variable	Value
SDEPOT	3.000000
SOUTLET(1)	0.000000
SOUTLET(2)	1.000000
SOUTLET(3)	0.000000
SOUTLET(4)	0.000000
SOUTLET(5)	1.000000
TBACK	.9041468
ERT(1)	4.094082
ERT(2)	8.094082
ERT(3)	4.094082
ERT(4)	4.094082
ERT(5)	10.09408

Observe that, from the expected number of units on backorder, the best solution is to put two units at the depot, and one unit at each of locations 2, 3, and 5. This version deals with only a single product and a single DC. See Sherbrooke (1992) for various extensions to this simple version.

17.8 DC With Holdback Inventory/Capacity

Fisher and Raman (1996) describe an approach, called “accurate response” used at the apparel firm, Sport Obermeyer, to help reduce inventories for style goods. The basic setting is two periods with multiple outlets. In the first period, some inventory or production capacity may be held back in order to be allocated in the second period to the outlets that look like they might otherwise run out in the second period. This model has an upper limit, *HBLIM*, on the amount of inventory or capacity that can be held back. In the Sport Obermeyer case, this corresponds to the limited production capacity available at the end of the first period to react to demands observed during the first period. The model allows demands in the second period to be correlated with demands in the first period via the *SHIFT* parameter in the same manner Fisher and Raman (1996) do for Sport Obermeyer. *SHIFT*(*R*, *S*) is the amount by which all demands for retail point (or product) *R*, are shifted up if the demand scenario in the first period was *S*.

```

MODEL:
! Holdback inventory model(HOLDBACK). A central facility
can holdback some inventory or capacity after the first
period to allocate to outlets likely to run out in
the second period;
SETS:
  RETAILP/1..2/: C, V, S1, P1, P2, H1, H2;
  SCENE1/1..4/;;
  SCENE2/1..3/;;
  RXS1( RETAILP, SCENE1): DEM1, SHIFT, Z1, ALLOC;
  RXS2( RETAILP, SCENE2): DEM2;
  RXS1XS2( RETAILP, SCENE1, SCENE2): Z2;
ENDSETS
DATA:
  C = 50 60; ! Cost/unit for each retail point;
  HBLIM = 80; ! Max available for period 2;
  V = 120 160; ! Selling price at each retail point;
  P1=10 11; ! Shortage penalty, lost sales, period 1;
  P2=12 17; ! Shortage penalty, lost sales, period 2;
  H0 = 4; ! Holding cost per unit in holdback;
  H1 = 5 6; ! Holding cost at end of period 1;
  H2 = -18 -23; ! At end of period 2;
  DEM1 = 90 60 100 210 ! Demands by scenario;
         50 102 87 45;
  DEM2 = 50 60 100
         70 45 87;
  SHIFT= 12 -10 13 19 ! Shift in period 2 demand;
         -11 14 -8 -15; ! based on period 1 demand;
ENDDATA
!-----;
! Count number of scenarios;
NS1 = @SIZE( SCENE1);
NS2 = @SIZE( SCENE2);
MAX = REVENUE - PCOST - SHORT1 - SHORT2 - HOLD0 - HOLD1 - HOLD2;
PCOST = @SUM( RXS1( I, K1):
             C( I) * ( S1( I) + ALLOC( I, K1))/NS1;
             );
! Amount ordered = held back + initial allocation;
S = HOLDBK + @SUM( RETAILP( I): S1( I));

```

```

! Limits on amount available for second period;
@BND( 0, HOLDBK, HBLIM);
! Set Z1 = lost sales in period 1;
@FOR( RXS1( I, K1):
  Z1( I, K1) >= DEM1( I, K1) - S1( I);
);
! Set Z2 = lost sales in period 2;
@FOR( RXS1XS2( I, K1, K2):
  Z2( I, K1, K2) >= DEM2( I, K2) + SHIFT( I, K1) -
  (S1( I) - DEM1( I, K1) + Z1( I, K1) + ALLOC( I, K1));
);
! Cannot allocate more than was held back;
@FOR( SCENE1( K1):
  @SUM( RETAILP( I): ALLOC( I, K1)) <= HOLDBK;
);
! Compute various average costs;
HOLD0 = H0 * HOLDBK;
HOLD1 = @SUM( RXS1( I, K1):
  H1( I) * ( S1( I) - DEM1( I, K1) + Z1( I, K1)))/ NS1;
! If there is a salvage value, HOLD2 could be < 0;
@FREE( HOLD2);
HOLD2 = @SUM( RXS1XS2( I, K1, K2): H2( I) *
  ( S1( I) - DEM1( I, K1) + Z1( I, K1) + ALLOC( I, K1)
  - DEM2( I, K2) - SHIFT( I, K1) + Z2( I, K1, K2))
  /( NS1 * NS2);
SHORT1 = @SUM( RXS1( I, K1): P1( I) * Z1( I, K1))/NS1;
SHORT2 = @SUM( RXS1XS2( I, K1, K2):
  P2( I) * Z2( I, K1, K2))/( NS1 * NS2);
REVENUE = @SUM( RXS1XS2( I, K1, K2): V( I) *
  ( DEM1( I, K1) - Z1( I, K1)
  + DEM2( I, K2) + SHIFT( I, K1) - Z2( I, K1, K2)))
  /( NS1 * NS2);
END

```

Part of the solution is:

```

Optimal solution found at step:          78
Objective value:                      23496.58

```

Variable	Value	Reduced Cost
REVENUE	44060.00	0.0000000
PCOST	20600.00	0.0000000
SHORT1	0.0000000	0.1000000
SHORT2	49.91667	0.0000000
HOLD0	320.0000	0.0000000
HOLD1	745.0000	0.0000000
HOLD2	-1151.500	0.0000000
S	406.0000	0.0000000
HOLDBK	80.00000	-2.000000
S1(1)	210.0000	0.0000000
S1(2)	116.0000	0.0000000
Z1(1, 1)	0.0000000	29.00000
Z1(1, 2)	0.0000000	29.00000
Z1(1, 3)	0.0000000	21.00000
Z1(1, 4)	0.0000000	0.0000000

Z1(2, 1)	0.0000000	28.97500
Z1(2, 2)	0.0000000	25.39167
Z1(2, 3)	0.0000000	28.97500
Z1(2, 4)	0.0000000	26.55833
ALLOC(1, 1)	0.0000000	8.000000
ALLOC(1, 2)	0.0000000	11.58333
ALLOC(1, 3)	3.000000	0.000000
ALLOC(1, 4)	79.00000	0.000000
ALLOC(2, 1)	10.00000	0.000000
ALLOC(2, 2)	80.00000	0.000000
ALLOC(2, 3)	50.00000	0.000000
ALLOC(2, 4)	1.000000	0.000000
Z2(1, 1, 1)	0.0000000	9.500000
Z2(1, 1, 2)	0.0000000	9.500000
Z2(1, 1, 3)	0.0000000	9.500000
Z2(1, 2, 1)	0.0000000	9.500000
Z2(1, 2, 2)	0.0000000	9.500000
Z2(1, 2, 3)	0.0000000	9.500000
Z2(1, 3, 1)	0.0000000	9.500000
Z2(1, 3, 2)	0.0000000	9.500000
Z2(1, 3, 3)	0.0000000	1.500000
Z2(1, 4, 1)	0.0000000	9.500000
Z2(1, 4, 2)	0.0000000	8.583333
Z2(1, 4, 3)	40.00000	0.000000
Z2(2, 1, 1)	0.0000000	12.83333
Z2(2, 1, 2)	0.0000000	12.83333
Z2(2, 1, 3)	0.0000000	3.583333
Z2(2, 2, 1)	0.0000000	12.83333
Z2(2, 2, 2)	0.0000000	12.83333
Z2(2, 2, 3)	7.000000	0.000000
Z2(2, 3, 1)	0.0000000	12.83333
Z2(2, 3, 2)	0.0000000	12.83333
Z2(2, 3, 3)	0.0000000	3.583333
Z2(2, 4, 1)	0.0000000	12.83333
Z2(2, 4, 2)	0.0000000	12.83333
Z2(2, 4, 3)	0.0000000	1.166666

The solution recommends ordering 406 units in total and holding back 80 units to allocate out later to the outlets that appear to need it. From the *ALLOC* variables, you can see that if scenario 4 occurs, then retail point 1 gets most of the held back units, otherwise retail point 2 gets most of the held back units.

17.9 Multiproduct, Constrained Dynamic Lot Size Problems

In many production settings, we know demand is not stationary. That is, the demand varies in a predictable way. If we are willing to disregard uncertainty, then efficient methods exist for scheduling production of products over time. One of the earliest occurrences of this problem was the case of a single product with no capacity constraints by Wagner and Whitin (1958). They referred to this problem as the dynamic lot size problem.

We will look at the more general case of multiple products. The most common interaction between products is competition for scarce resources. We first consider the case where each product has essentially the same cost and demand structure as a single product dynamic lot size problem. The

products interact by competing for scarce production capacity. This situation can be thought of as a single stage material requirements planning (MRP) problem where production capacities, setup costs, and holding costs are explicitly considered and optimum solutions are sought.

Examples might be the scheduling of production runs of different types of home appliances on an appliance assembly line or the scheduling of different types of automotive tires onto a tire production line. In the applications described by Lasdon and Terjung (1971) and King and Love (1981), several dozen tire types compete for scarce capacity on a few expensive tire molding machines.

The general situation can be described formally by the following example.

17.9.1 Input Data

P = number of products;

T = number of time periods;

d_{it} = demand for product i in period t , for $i = 1, 2, \dots, P$; $t = 1, 2, \dots, T$;

h_{it} = holding cost charged for each unit of product i in stock at end of period t ;

c_{it} = cost per unit of each product i produced in period t ;

s_{it} = setup cost charged if there is any production of product i in period t ;

a_t = production capacity in period t . We assume the units (e.g., ounces, pounds, grams, etc.) have been chosen for each product, so producing one unit of any product uses one unit of production capacity.

There have been many mathematical programming formulations of this problem. Many of them bad from a computational viewpoint. Lasdon and Terjung (1971) describe a good formulation that has been profitably used for many years at the Kelly-Springfield Tire Company. The following formulation due to Eppen and Martin (1987) appears to be one of the best and enjoys the additional benefit of being moderately easy to describe. The decision variables used in this formulation are:

x_{ist} = fraction of demand in periods s through t of product i , which is produced in period s , where:

$$1 \leq s \leq t \leq T;$$

= 0 otherwise.

y_{it} = 1 if any product i is produced in period t ,

= 0 otherwise.

It is useful to compute the variable cost associated with variable x_{ist} . It is:

$$g_{ist} = c_{is} * (d_{is} + d_{i,s+1} + \dots + d_{it}) + d_{i,s+1} * h_{is} + d_{i,s+2} * (h_{is} + h_{i,s+1}) + \dots + d_{it} * (h_{is} + h_{i,s+1} + \dots + h_{i,t-1})$$

Similarly, it is useful to compute the amount of production, p_{ist} , in period s associated with using variable x_{ist} :

$$p_{ist} = d_{is} + d_{i,s+1} + \dots + d_{it}$$

The objective function can now be written:

$$\text{Min} \sum_{i=1}^P \left(\sum_{t=1}^T s_{it} y_{it} + \sum_{s=1}^T \sum_{t=2}^T g_{ist} x_{ist} \right)$$

There will be three types of constraints. Specifically:

- constraints that cause demand to be met each period for each product,
- constraints that, for each product and period, force a setup cost to be incurred if there was any production of that product, and
- constraints that force total production to be within capacity each period.

The constraints can be written as:

$$\begin{aligned} \text{a) } & \sum_{t=1}^T x_{it} = 1, \text{ for } i = 1, 2, \dots, P, \\ & \sum_{t=s}^T x_{ist} - \sum_{r=1}^{s-1} x_{irs-1} = 0, \quad \text{for } i = 1, 2, \dots, P \text{ and } s = 2, 3, \dots, T \\ \text{b) } & y_{is} - x_{iss} - x_{is,s+1} - \dots - x_{is,T} \geq 0, \text{ for } i = 1, 2, \dots, P, \text{ and } s = 1, 2, \dots, T, \\ \text{c) } & \sum_{i=1}^P \sum_{t=s}^T p_{ist} + x_{ist} \quad \text{for } s = 1, 2, \dots, T \end{aligned}$$

All variables are required to be nonnegative. y_{it} is required to be either 0 or 1.

If any of the $d_{it} = 0$, then there must be a slight modification in the formulation. In particular, if $p_{ist} = 0$, then x_{ist} should not appear in constraint set (b). Also, if $p_{ist} = 0$ and $s < t$, then variable x_{ist} may be dropped completely from the formulation.

17.9.2 Example

The parameters of a two-product, constrained, dynamic lotsize problem are as follows:

Demand	May	June	July	August	September	October
Product A:	40	60	100	40	100	200
Product B:	20	30	40	30	25	35
Setup Cost						
Product A:	100	100	150	150	205	200
Product B:	30	40	30	55	45	45
Variable Cost/Unit						
Product A:	5	6	7	8	9	10
Product B:	2	4	4	5	5	5
Unit holding cost/period						
Product A:	1	1	2	2	3	2
Product B:	2	1	1	2	1	2

Production capacity is 200 units per period, regardless of product. Two products can be produced in a period.

An LP/IP formulation for this example appears as follows:

```

MODEL:
! Two Product Capacitated Lot-sizing Problem.
!   Yit = 1 if product i is produced in period t,
!   XAst = 1 if demands in periods s through t are
! satisfied from production in period s, for product
!   A,
!   XBst = 1 etc. for product B;
MIN = 100* YA1 + 100* YA2 + 150* YA3
+ 150* YA4 + 205* YA5 + 200* YA6
+ 30* YB1 + 40* YB2 + 30* YB3
+ 55* YB4 + 45* YB5 + 45* YB6
+ 200* XA11 + 560* XA12 + 1260* XA13
+ 1620* XA14 + 2720* XA15 + 5520* XA16
+ 360* XA22 + 1060* XA23 + 1420* XA24
+ 2520* XA25 + 5320* XA26 + 700* XA33
+ 1060* XA34 + 2160* XA35 + 4960* XA36
+ 320* XA44 + 1320* XA45 + 3920* XA46
+ 900* XA55 + 3300* XA56 + 2000* XA66
+ 40* XB11 + 160* XB12 + 360* XB13
+ 540* XB14 + 740* XB15 + 1055* XB16
+ 120* XB22 + 320* XB23 + 500* XB24
+ 700* XB25 + 1015* XB26 + 160* XB33
+ 310* XB34 + 485* XB35 + 765* XB36
+ 150* XB44 + 325* XB45 + 605* XB46
+ 125* XB55 + 335* XB56 + 175* XB66;
! For product A:
!   If a production lot was depleted in period
! i-1 (the - terms), then a production run of some !sort must be
started in period i (the + terms);
[A1] + XA11 + XA12 + XA13 + XA14 + XA15 + XA16 = + 1;
[A2] - XA11 + XA22 + XA23 + XA24 + XA25 + XA26 = 0;
[A3] - XA12 - XA22 + XA33 + XA34 + XA35 + XA36 = 0;
[A4] - XA13 - XA23 - XA33 + XA44 + XA45 + XA46 = 0;
[A5] - XA14 - XA24 - XA34 - XA44 + XA55 + XA56 = 0;
[A6] - XA15 - XA25 - XA35 - XA45 - XA55 + XA66 = 0;
! The setup forcing constraints for A;
[FA1] YA1 - XA11 - XA12 - XA13 - XA14 - XA15
- XA16 >= 0;
[FA2] YA2 - XA22 - XA23 - XA24 - XA25 - XA26 >= 0;
[FA3] YA3 - XA33 - XA34 - XA35 - XA36 >= 0;
[FA4] YA4 - XA44 - XA45 - XA46 >= 0;
[FA5] YA5 - XA55 - XA56 >= 0;
[FA6] YA6 - XA66 >= 0;
! Same constraints for product B;
[B1] + XB11 + XB12 + XB13 + XB14 + XB15 + XB16 = + 1;
[B2] - XB11 + XB22 + XB23 + XB24 + XB25 + XB26 = 0;
[B3] - XB12 - XB22 + XB33 + XB34 + XB35 + XB36 = 0;
[B4] - XB13 - XB23 - XB33 + XB44 + XB45 + XB46 = 0;
[B5] - XB14 - XB24 - XB34 - XB44 + XB55 + XB56 = 0;
[B6] - XB15 - XB25 - XB35 - XB45 - XB55 + XB66 = 0;

```

```

! The setup forcing constraints;
[FB1] YB1 - XB11 - XB12 - XB13 - XB14 - XB15
      - XB16 >= 0;
[FB2] YB2 - XB22 - XB23 - XB24 - XB25 - XB26 >= 0;
[FB3] YB3 - XB33 - XB34 - XB35 - XB36 >= 0;
[FB4] YB4 - XB44 - XB45 - XB46 >= 0;
[FB5] YB5 - XB55 - XB56 >= 0;
[FB6] YB6 - XB66 >= 0;
! Here are the capacity constraints for each period;
!The coefficient of a variable is the associated lotsize;
[CAP1] 40* XA11 + 100* XA12 + 200* XA13
      + 240* XA14 + 340* XA15 + 540* XA16
      + 20* XB11 + 50* XB12 + 90* XB13 + 120* XB14
      + 145* XB15 + 180* XB16 <= 200;
[CAP2] 60* XA22 + 160* XA23 + 200* XA24
      + 300* XA25 + 500* XA26 + 30* XB22
      + 70* XB23 + 100* XB24 + 125* XB25 + 160* XB26
      <= 200;
[CAP3] 100* XA33 + 140* XA34 + 240* XA35
      + 440* XA36 + 40* XB33 + 70* XB34
      + 95* XB35 + 130* XB36 <= 200;
[CAP4] 40* XA44 + 140* XA45 + 340* XA46
      + 30* XB44 + 55* XB45 + 90* XB46 <= 200;
[CAP5] 100* XA55 + 300* XA56 + 25* XB55
      + 60* XB56 <= 200;
[CAP6] 200* XA66 + 35* XB66 <= 200;
! Declare the setup variables integer;
@BIN( YA1); @BIN( YA2);
@BIN( YA3); @BIN( YA4);
@BIN( YA5); @BIN( YA6);
@BIN( YB1); @BIN( YB2);
@BIN( YB3); @BIN( YB4);
@BIN( YB5); @BIN( YB6);
END

```

The interpretation of the X_{ijk} variables and the constraint rows 2 through 7 can perhaps be better understood with the picture in the figure below:

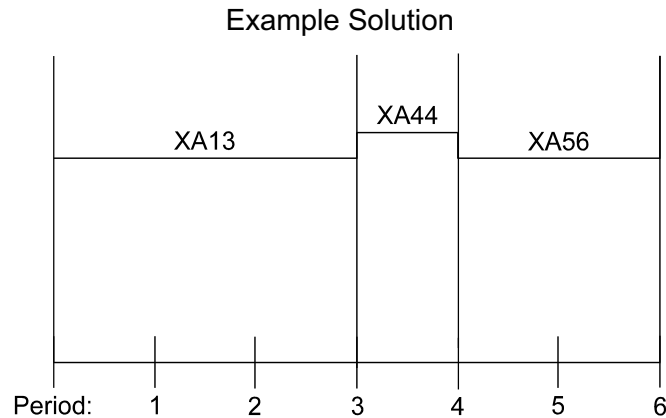

The demand constraints, 2 through 7, force us to choose a set of batch sizes to exactly cover the interval from 1 to 6. If an arrow from period 1 terminates at the end of period 3 (production run in period 1 is sufficient for only the first three periods), then another arrow must start at the end of period 3.

If we solve it as an LP (i.e., with the constraints $Y_{it} = 0$ or relaxed to $0 \leq Y_{it} \leq 1$), we get a solution with cost \$5,968.125.

When solved as an IP, we get the following solution:

Objective Function Value	6030.00000
Variable	Value
YA1	1.000000
YA2	1.000000
YA6	1.000000
YB1	1.000000
YB3	1.000000
YB5	1.000000
XA11	0.666667
XA15	0.333333
XA25	0.666667
XA66	1.000000
XB12	1.000000
XB34	1.000000
XB56	1.000000

The production amounts can be read off the coefficients of the nonzero X variables in the capacity constraints of the LP. This solution can be summarized as follows:

Product A		Product B	
Period	Production	Period	Production
1	140 ($0.6667 \times 40 + 0.3333 \times 340$)	1	50
2	200 (0.6667×300)	2	0
3	0	3	70
4	0	4	0
5	0	5	60
6	200	6	0

A general, set-based formulation for this example follows:

```

MODEL:
SETS: ! Multiproduct capacitated lotsizing (CAPLOT);
    TIME ;
    PROD: ST, ! Setup time for product I;
    PT; ! Production time/unit for product I;
    PXT( PROD, TIME):
    D, ! Demand for prod I in period S;
    K, ! Setup cost for prod I in period S;
    C, ! Cost/unit for prod I in period S;
    H, ! Holding cost/unit for prod I, end of period S;
    MAKE, ! Amount to make of I in period S;
    Y; ! = 1 if produce I in period S, else 0;
    PXTXT( PROD, TIME, TIME) | &2 #LE# &3:
    X, ! Fraction of demands in S through T satisfied
        by production in period S;
    VC, ! Variable cost of getting an item from S to T;
    TP; ! Total production in the batch: (I,S,T);
ENDSETS
DATA:
    CAP = 200; ! Capacity each period;
    PROD= A, B; ! The products;
    ST = 0 0; ! Setup time for each product;
    PT = 1 1; ! Production time/unit for each product;
    TIME= MAY JUN JUL AUG SEP OCT;
    D = 40 60 100 40 100 200
        20 30 40 30 25 35;
    K = 100 100 150 150 205 200
        30 40 30 55 45 45;
    H = 1 1 2 2 3 2
        2 1 1 2 1 2;
    C = 5 6 7 8 9 10
        2 4 4 5 5 5;
ENDDATA
!-----;
@FOR( PXT( I, S):
    VC( I, S, S) = C( I, S);
    TP( I, S, S) = D( I, S);
);
@FOR( PXTXT( I, S, T) | S #LT# T:
    ! Variable cost of getting product I from S to T;
    VC( I, S, T) = VC( I, S, T-1) + H( I, T - 1);
    ! Total demand for I over S to T;
    TP( I, S, T) = TP( I, S, T-1) + D( I, T);
);
MIN = @SUM( PXT( I, T): K( I, T) * Y( I, T))
    + @SUM( PXTXT( I, S, T):
        X( I, S, T) *
            @SUM( PXT( I, J) | S #LE# J #AND# J #LE# T:
                D( I, J) * VC( I, S, J)));
! Capacity constraints;
@FOR( TIME( S):
    @SUM( PXT( I, S): ST( I) * Y( I, S)) +

```

```

    @SUM( PXTXT( I, S, T):
      TP( I, S, T) * PT( I) * X( I, S, T)) <= CAP;);
! Demand constraints;
@FOR( PROD( I):
! First period must be covered;
  @SUM( PXTXT( I, S, T)| S #EQ# 1: X( I, 1, T)) = 1;
! For subsequent periods, if a run ended in S-1, then
we must start a run in S;
  @FOR( TIME( S)| S #GT# 1:
    @SUM( PXT( I, J)| J #LT# S: X( I, J, S - 1)) =
    @SUM( PXTXT( I, S, J): X( I, S, J));
  ); );
! Setup forcing constraints;
@FOR( PXT( I, S):
  @BIN( Y( I, S));
  Y( I, S) >= @SUM( PXTXT( I, S, T):
    @SIGN( TP( I, S, T)) * X( I, S, T));
  );
! Compute amount made in each period;
@FOR( PXT( I, S):
  @FREE( MAKE( I, S));
  MAKE( I, S) =
  @SUM( PXTXT( I, S, T): TP( I, S, T) * X( I, S, T));
  );
END

```

With comparable solution:

```

Optimal solution found at step:      110
Objective value:                    6030.000
Branch count:                        2

```

Variable	Value	Reduced Cost
MAKE(A, 1)	150.0000	0.0000000
MAKE(A, 2)	190.0000	0.0000000
MAKE(A, 6)	200.0000	0.0000000
MAKE(B, 1)	50.00000	0.0000000
MAKE(B, 3)	70.00000	0.0000000
MAKE(B, 5)	60.00000	0.0000000

Thus, we make production runs for product A in periods 1, 2, and 6. Production runs for product B are made in periods 1, 3, and 5.

17.9.3 Extensions

There are a variety of extensions to this model that may be of practical interest, such as:

Carry-over-setups. It may be a setup cost is incurred in period s only if there was production in period s , but no production in period $s - 1$. A straightforward, though not necessarily good, way of handling this is by introducing a new variable, z_{it} , related to y_{it} by the relationship: $z_i \geq y_{it} - y_{i,t-1}$. The setup cost is charged to z_{it} rather than y_{it} .

Multiple machines in parallel. There may be a choice among M machines on which a product can be run. This may be handled by appending an additional subscript m , for $m = 1, 2, \dots, M$, to the x_{ist} and y_{it} variables. The constraints become:

$$(a) \sum_{t=1}^T \sum_{m=1}^M x_{istm} = 1 \quad \text{for } i = 1, 2, \dots, P,$$

$$\sum_{t=s}^T \sum_{m=1}^m x_{istm} - \sum_{r=1}^{s-1} \sum_{m=1}^M x_{i,r,s-l,m} = 0 \quad \text{for } i = 1, 2, \dots, P;$$

$$s = 2, \dots, T.$$

$$(b) y_{ism} - x_{issm} - x_{i,s,s+1,m} - \dots - x_{i,s,T,m} \leq 0 \quad \text{for } i = 1, 2, \dots, P;$$

$$s = 1, 2, \dots, T;$$

$$m = 1, 2, \dots, m.$$

$$(c) \sum_{i=1}^P \sum_{t=s}^T p_{pstm} x_{istm} \leq a_{sm} \quad \text{for } s = 1, 2, \dots, T, \text{ and}$$

$$m = 1, 2, \dots, M.$$

If the machines are non-identical, then the manner in which p_{istm} is calculated will be machine dependent.

17.10 Problems

1. The Linear Products Company (LPC) of Gutenberg, Iowa, distributes a folding bicycle called the Brompton. Demand for the Brompton over the past year has been at the rate of 5.9 per month, fairly uniformly distributed over the year. The Brompton is imported from a manufacturer in the United Kingdom. For a variety of reasons, including customs processing, small size of the manufacturer, averages of ocean shipping, and getting the shipment from the port of entry to Iowa, the lead time from the manufacturer to LPC is two months. The fixed cost of placing an order, taking into account international phone calls, shipping cost structure, and general order processing is \$200. The cost and selling price per bicycle vary depending upon the features included, but a typical Brompton costs LPC \$500. LPC sells a typical Brompton for \$900. LPC uses a cost of capital of 12% per year.
 - a) What order size do you recommend for LPC?
 - b) LPC did a statistical analysis of their sales data for the past year and found the standard deviation in monthly demand to be 2.1. LPC estimates a customer who is ready to buy, but finds LPC out of stock, will buy from someone else with probability .8, rather than wait. What reorder point do you recommend for LPC?
 - c) LPC did an analysis of their inbound shipments and found that the lead time has a standard deviation of 3 weeks. Extending (b) above, how much is this lead time uncertainty costing LPC?
 - d) Suppose LPC could reduce lead time to a reliable one month. Compared to (c) above, how much would this change be worth?

2. A company keeps fleets of vehicles at a number of sites around the country. At each site, the vehicles can be classified into two types, light and heavy. A heavy vehicle costs more per day, but it can do any task that a light vehicle can do. A question of some concern is what mix of vehicles should the company have at each site. If the firm does not have enough vehicles of the appropriate size to meet the demand on a given day, it rents the vehicles. Some cost data were collected on the cost of various vehicle types:

Vehicle type	Daily fixed cost	Daily variable cost(if used)
Owned Light	\$32	\$40
Owned Heavy	\$44	\$54
Rented Light	0	\$175
Rented Heavy	0	\$225

At a particular site, the company collected demand data for the number of vehicles required on each of seven days:

Day	Lights	Heavies
1	6	0
2	3	2
4	8	3
5	2	1
6	4	4
7	1	2

Based on just the above data, what is your recommendation for the number of vehicles to own of each type?

- 3) A recent option in U.S. tax law is the flexible spending account. If you exploit this option, you are allowed to specify before the year begins, an amount of your salary to be withheld and placed into a "flexible spending" account. During the year, you may withdraw from this account to pay medical expenses that are neither covered by your regular medical insurance, nor deductible on your income tax return as expenses. This account has a "use or lose it" nature in that any money left over in the account at the end of the year is lost to you. You are otherwise not taxed on the amount of money you set aside in this account.
- Suppose your tax rate is 35% and you estimate that your uncovered medical expenses during next year have an expected amount of \$2400 with a standard deviation of \$1100. You are contemplating setting aside S before tax dollars. Write an expression for the expected after tax value of setting aside one more dollar.
 - How much money should you set aside?
 - How would you go about estimating the distribution of your medical expenses for next year?

Design & Implementation of Service and Queuing Systems

*"If you think you have reservations, you're at the wrong place."
-Sign in Ed Debevec's Restaurant*

18.1 Introduction

The distinctive feature of a service system is that it cannot stock its product in anticipation of impending demand. An organization whose main product is a service can prepare for increased demand only by increasing its capacity. A major question in planning a service system is capacity sizing. How many cashiers, ticket takers, staffers at a toll plaza, phone lines, computers at an internet service provider, runways at an airport, tables at a restaurant, fire stations, beds in a hospital, police cars in a region, restroom facilities, elevators, or machine maintenance personnel are needed so as to provide acceptable service?

Capacity planning for a service facility involves three steps:

1. Data collection. Assemble all relevant historical data or set up a system for the on-going collection of demand data.
2. Data analysis. Forecast demand; ascertain the probabilistic components of the demand; determine the minimum acceptable capacity for each demand period.
3. Requirements recommendation. Taking into account such factors as the probabilistic nature of demand, cost of poorly served demand, capacity change costs and standard work shift patterns, recommend a capacity plan that minimizes all relevant expected costs.

18.2 Forecasting Demand for Services

Standard forecasting methods apply as well to demand for services as to the demand for goods. Long-range forecasting of demand for services must incorporate the fact that demand for services does not react to changes in the health of the economy in the same way as demand for goods. For example, demand for goods such as food is relatively unaffected by the health of the economy; whereas, demand for luxury services such as restaurant dining tends to be diminished by economic recessions. Demand for fast food dining service has been increased by the advent of the working mother.

Shorter range forecasting of the demand for services is concerned in large part with the measurement of the cyclical components of demand. In particular, one wants to identify (say for a service that processes phone calls) the:

- hour of the day effect,
- day of the week effect (e.g., the number of calls per day to the 911 emergency number in New York City has been found to vary somewhat predictably almost by a factor of two based on the day of the week),
- week of year effect,
- moveable feast effect (e.g., Mother's Day, Labor Day, Easter, etc),
- advertising promotions.

18.3 Waiting Line or Queuing Theory

Queuing theory is a well-developed branch of probability theory that has long been used in the telephone industry to aid capacity planning. A. K. Erlang performed the first serious analysis of waiting lines or queues for the Copenhagen telephone system in the early 20th century. Erlang's methods are still widely used today in the telephone industry for setting various capacities such as operator staffing levels. For application at the mail order firm, L.L. Bean, see Andrews and Parsons (1993). Gaballa and Pearce (1979) describe applications at Qantas Airline. An important recent application of queuing models is in telephone call centers. There are two kinds of call centers: 1) In-bound call centers that handle incoming calls, such as orders for a catalog company, or customer support for a product; and 2) Out-bound call centers where telephones place calls to prospective customers to solicit business, or perhaps to remind current customers to pay their bills.

It is useful to note that a waiting line or queue is usually the negative of an inventory. Stock carried in inventory allows an arriving customer to be immediately satisfied. When the inventory is depleted, customers must wait until units of product arrive. The backlogged or waiting customers constitute a negative inventory, but they can also be thought of as a queue. A more explicit example is a taxi stand. Sometimes taxi cabs will be in line at the stand waiting for customers. At other times, customers may be in line waiting for cabs. What you consider a queue and what you consider an inventory depends upon whether you are a cab driver or a cab customer.

In queuing theory, a service system has three components:

- 1) an arrival process,
- 2) a queue discipline, and
- 3) a service process.

The figure below illustrates:

<u>Arrival Process</u>	→	<u>Queue discipline</u>	→	<u>Service Process</u>
(e.g., One arrival every 7 minutes on average.)		(e.g., First-come first-serve), but if 10 are waiting, then arrivals are lost.		(e.g., 3 identical servers). Mean service time is 9 minutes.

A good introduction to queuing theory can be found in Gross and Harris (1998).

18.3.1 Arrival Process

We distinguish between two types of arrival process: i) finite source and ii) infinite source. An example of finite source is 10 machines being watched over by a single repair person. When a machine breaks down, it corresponds to the arrival of a customer. The number of broken down machines awaiting repair is the number of waiting customers. We would say this system has a finite source of size ten. With a finite population, the arrival rate is reduced as more customers enter the system. When there are already 8 of 10 machines waiting for repairs or being repaired, then the arrival rate of further customers (broken machines) is only 2/10 of the arrival rate if all the machines were up and running and thus eligible to breakdown.

An airline telephone reservation system, on the other hand, would typically be considered as having an infinite calling population. With an infinite population, the arrival rate is unaffected by the number of customers already in the system.

In addition to the type of arrival process, a second piece of information we need to supply is the mean time between calls. If the calling population is infinite, then this is a single number independent of the service process. However, for a finite population, there is a possibility for ambiguity because the arrival rate at any moment depends upon the number waiting. The ambiguity is resolved by concentrating on only one of the supposedly identical customers. It is sufficient to specify the mean time until a given customer generates another call, given that he just completed service. We call this the *mean time between failures* or MTBF for short.

A fine point that we are glossing over is the question of the distribution (as opposed to the mean) of the time between calls. Two situations may have the same mean time between calls, but radically different distributions. For example, suppose that in situation 1 every interval between calls is exactly 10 minutes, while, in situation 2, 10% of the intervals are 1 minute long and 90% of the intervals are 11 minutes. Both have the same mean, but it seems plausible that system 2 will be more erratic and will incur more waiting time. The standard assumption is that the distribution of the time between calls is the so-called exponential. Happily, it appears that this assumption is not far off the mark for most real situations.

The exponential distribution plays a key role in the models we will consider. For the infinite source case, we assume that the times between successive arrivals are distributed according to the exponential distribution. An exponential density function is graphed in the figure 18.1:

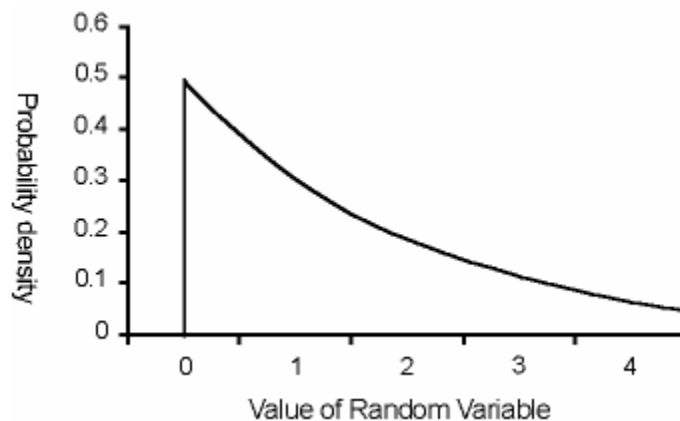

Figure 18.1. An exponential distribution with mean 2.

If r is the arrival rate, x is a value of the random variable, and e is the number 2.718284, then the frequency or density function plotted in Figure 18.1, is given by $f(x) = re^{-rx}$. The mean and standard deviation are both $1/r$. The key assumption underlying the exponential distribution is that the probability that the event of interest (e.g., the arrival of a customer or the breakdown of a specified machine) is a constant is independent of when the previous event occurred. Another way of stating this feature is via the “memoryless property”. That is, regardless of how long it has been since the previous arrival, the distribution of the time until the next arrival has the exponential distribution with mean $1/r$.

18.3.2 Queue Discipline

All the models we consider use a first-come first-serve queue discipline. The only other piece of information required is the waiting capacity of the system. Calls or customers that arrive while there is waiting space join the system and, if necessary, wait for service. A demand or customer that finds all waiting spaces filled is lost. Examples are: a reservation office that has 10 incoming phone lines, but only four reservationists. A reservationist puts an incoming call on “hold” if all reservationists are already occupied. If all 10 lines are occupied, a caller will get a “busy” signal. An analogous system is a gasoline station with 4 pumps and room for 6 cars to wait behind the 4 cars being served. A prospective customer is said to balk if s/he refuses to join the queue. A somewhat similar action, reneging, is said to occur if a customer decides to leave the queue while waiting.

18.3.3 Service Process

The service process is characterized by two attributes:

- a) the number of servers (assumed identical).
- b) the service time distribution.

The most common assumption is that service times follow the exponential distribution.

An implication of this distribution is that the mean service time equals the standard deviation. Therefore, comparing the mean with the standard deviation is a simple data check.

In contrast to arrival processes, there is little a priori justification for expecting any particular type of service time distribution. One must examine the data closely to select the appropriate approximate distribution. If the standard deviation in service time is much smaller than the mean service time, then a constant service time is a reasonable approximation. If the standard deviation approximately equals the mean, then the exponential assumption is reasonable.

The exponential distribution fits surprisingly well in many situations. Coffman and Wood (1969), for example, found that job compute times on a computer had a standard deviation somewhat higher than the mean. Nevertheless, the shape of the distribution was essentially exponential-like with the peak close to zero and a long tail to the right.

18.3.4 Performance Measures for Service Systems

There is a variety of measures of performance of a service system. The three measures we will consider are:

- 1) Probability of immediate service.
- 2) Average waiting time.
- 3) Average number waiting.

18.3.5 Stationarity

In general, queuing models assume that demand is stationary (i.e., stable over time) or that the system has reached steady state. Obviously, this cannot be true if demand is spread over a sufficiently long period of time (e.g., an entire day). For example, it is usually obvious that the mean time between phone calls at 11:00 a.m. on any given day is not the same as the mean time at 11:00 p.m. of that same day. We define the load on a service system as the product of the mean arrival rate times the mean service time per customer. Load is a unit-less quantity, which is a lower bound on the number of servers one would need to process the arriving work without having the queue grow without bound. We should probably be careful about using a steady-state-based queuing model if load is not constant for a reasonably long interval. What constitutes a “reasonable long interval”? To answer that question, let us define a notation we will use henceforth:

R = mean arrival rate,
 T = mean or expected service time,
 S = number of servers.

The quantity $T/(S - R \cdot T)$ is a simple definition of “a reasonably long interval”. Notice that it becomes unbounded as the load approaches S.

18.3.6 A Handy Little Formula

There is a very simple yet general relationship between the average number in system and the average time in system. In inventory circles, this relationship is known as the inventory turns equation. In the service or queuing world, it is known as Little's Flow Equation, see Little (1961). In words, Little's equation is:

$$(\text{average number in systems}) = (\text{arrival rate}) * (\text{average time-in-system})$$

Reworded in inventory terminology, it is:

$$(\text{average inventory level}) = (\text{sales rate}) * (\text{average time-in-system})$$

Inventory managers frequently measure performance in "inventory turns", where:

$$(\text{inventory turns}) = 1/(\text{average time-in-system}).$$

Rearranging the Little's Flow equation:

$$(\text{average inventory level}) = (\text{sales rate})/(\text{inventory turns})$$

or

$$(\text{inventory turns}) = (\text{sales rate})/(\text{average inventory level})$$

Little's Equation is very general. The only essential requirement is that the system to which it is applied cannot be drifting off to infinity. No particular probabilistic assumptions are required.

18.3.7 Example

Customers arrive at a rate of 25 per hour on average. Time-in-system averages out to 12 minutes. What is the average number of customers in system?

$$\begin{aligned} \text{Ans. } (\text{Average number in system}) &= (25/\text{hour}) * 12 \text{ minutes} * 1 \text{ hour}/60 \text{ minutes} \\ &= 25 * (1/5) = 5 \end{aligned}$$

18.4 Solved Queuing Models

There are five situations or models that we will consider. They are summarized in Table 1. The key feature of these situations is that there are fairly simple formulae describing the performance of these systems.

Table 1:
Solved Service System Models

Model	I	II	III	IV	V
Feature					
Queue Notation	(M/G/c/c)	(M/M/c)	(M/G/∞)	(F/M/c)	(M/G/1)
Population Size	Infinite	Infinite	Infinite	Finite	Infinite
Arrival Process	Poisson	Poisson	Poisson	General	Poisson
Waiting Space	None	Infinite	Infinite	Infinite	Infinite
Number of Servers	Arbitrary	Arbitrary	Infinite	Arbitrary	1
Service distribution	Arbitrary /General	Exponential	Arbitrary /General	Exponential	Arbitrary /General
Solve with	@PEL or B(s,a)	@PEB or C(s,a)	@PPS or Poisson	@PFS	Formula

The five models are labeled by the notation typically used for them in queuing literature. The notation is of the form (*arrival process/service distribution/number of servers [number spaces available]*) where:

- M* = exponential (or Markovian) distributed,
- G* = general or arbitrary,
- D* = deterministic or fixed, and
- F* = finite source.

The two “workhorse” models of this set of five are a) the *M/G/c/c*, also known as the Erlang loss or Erlang-B model, and b) the *M/M/c*, also known as the Erlang C model. LINGO has two built-in functions, @PEL() and @PEB() that “solve” these two cases. Their use is illustrated below.

18.4.1 Number of Outbound WATS lines via Erlang Loss Model

Some companies buy a certain number of outbound WATS (Wide Area Telephone Service) lines in order to reduce their long distance charges. An outbound WATS line allows you to make an unlimited number of long distance calls for a fixed fee. The fixed fee is low enough, so that, if you make a lot of calls, the cost per call is much lower than if you paid the standard cost/minute rate. Suppose that our company makes an average of 5 long distance calls per minute during the business day. The average duration of a call is 4 minutes. The system can be set up, so that, if one of our employees dials a long distance number, the call will be assigned to a WATS line if one of our WATS lines is available, else the call will use a regular line at regular rates for the duration of the call. Suppose we acquire 20 WATS lines. What fraction of the calls would find all WATS lines busy and thus use a regular line? An appropriate model is:

```

! Erlang Loss Model;
! Any demands that find all servers busy,
  are lost;
DATA:
! Arrival rate;
  R = 5;
! Average service time;
  T = 4;
! Number of servers;
  S = 20;
ENDDATA
LOAD = R * T;
! Compute fraction lost;
FLOST = @PEL( LOAD, S);

```

The solution is:

Variable	Value
R	5.000000
T	4.000000
S	20.000000
LOAD	20.000000
FLOST	0.1588920

Thus, even though we have enough WATS line capacity to handle the average demand, nevertheless because of randomness, almost 16% of the demand is lost (i.e., overflows into the regular lines).

There is a statistical economy of scale in service demand (i.e., twice the demand does not require us to have twice the capacity). To illustrate, suppose we forecast great growth next year and expect the outbound call rate to be 50 calls per minute rather than 5. If again we acquire just enough WATS lines to handle the average demand, $50 \times 4 = 200$, what fraction of the demand will overflow? If we substitute $R = 50$ into the model, we get the solution:

Variable	Value
R	50.000000
T	4.000000
S	200.0000
LOAD	200.0000
FLOST	0.05435242

The fraction overflow has dropped to approximately, 5%, even though we are still setting capacity equal to the average demand.

18.4.2 Evaluating Service Centralization via the Erlang C Model

The Ukallus Company takes phone orders at two independent offices and is considering combining the two into a single office, which can be reached via an "800" number. Both offices have similar volumes of 50 phone calls per hour (= .83333/minute) handled by 4 order takers in each office. Each office has sufficient incoming lines that automatically queue calls until an order taker is available. The time to process a call is exponentially distributed with mean 4 minutes.

How much would service improve if it were centralized to an office with 8 order takers? The results are:

	Two-Office System	One Central Office
Fraction of calls finding All servers busy	.6577	.533
Expected waiting time for calls that wait	6 minutes	3 minutes
Expected overall (including calls that do not wait) waiting	3.95 minutes	1.60 minutes

Thus, the centralized office provides noticeably better (almost twice as good depending upon your measure), service with the same total resources. Alternatively, the same service level could be achieved with somewhat fewer resources.

The above statistics can be computed using the following LINGO model. Note that throughout, we define a customer's wait as the customer's time in system until her service starts. The waiting time does not include the service time.

```

! Compute statistics for a multi-server system with(QMMC)
  Poisson arrivals, exponential service time distribution.
  Get the system parameters;
DATA:
  R = .8333333;
  T = 4;
  S = 4;
ENDDATA

! The model;
! Average no. of busy servers;
  LOAD = R * T;
! Probability a given call must wait;
  PWAIT = @PEB( LOAD, S);
! Conditional expected wait, i.e., given must wait;
  WAITCND = T/( S - LOAD);
! Unconditional expected wait;
  WAITUNC = PWAIT * WAITCND;

```

The solution is:

Variable	Value
R	.833333
T	4.000000
S	4.000000
LOAD	3.333333
PB	.6577216
CW	6.0000000
UW	3.946329

18.4.3 A Mixed Service/Inventory System via the M/G/ ∞ Model

Suppose that it takes us 6 minutes to make a certain product (e.g., a hamburger). Demand for the product arrives at the rate of 2 per minute. In order to give good service, we decide that we will carry 10 units in stock at all times. Thus, whenever a customer arrives and takes one of our in-stock units, we immediately place an order for another one. We have plenty of capacity, so that, even if we have lots of units in process, we can still make a given one in an average time of 6 minutes. Customers who find us out of stock will wait for a new one to be made. This is called a base stock policy with backlogging:

Analysis: The number of units on order will have a Poisson distribution with mean = $2 \times 6 = 12$. Thus, if a customer arrives and there are 2 or less on order, it means there is at least one in stock. The following model will compute the fraction of customers who have to wait.

```
! The M/G/infinity or Base stock Model;
DATA:
  ! Arrival rate;
  R = 2;
  ! Average service time;
  T = 6;
  ! Number units in stock;
  S = 10;
ENDDATA
LOAD = R * T;
! Compute fraction who have to wait;
FWAIT = 1 - @PPS( LOAD, S - 1);
! Note, @PPS( LOAD, X) =
  Prob{ a Poisson random variable with mean = LOAD
  has a value less-than-or-equal-to X};
```

The solution is:

Variable	Value
R	2.000000
T	6.000000
S	10.00000
LOAD	12.00000
FWAIT	0.7576077

Thus, more than 75% will have to wait.

18.4.4 Optimal Number of Repairmen via the Finite Source Model.

A textile firm has 10 semiautomatic machines, which occasionally need the services of a repairman, (e.g., if a thread breaks) in order to put the machine back in service. The repair time has an exponential distribution with a mean of 1 hour. Physical reasons imply that only one repairman work on a machine at a time (i.e., a helper does not help). Once repaired, the mean time until the machine jams again is 5 hours. The cost of a fully equipped repairman is \$30 per hour. The opportunity cost of a jammed machine is \$350 per hour. How many repairmen should be assigned to these 10 machines?

Using the @PFS function in LINGO, we can construct the following table of expected number of inoperative machines as a function of the number of repairmen:

No. of Repairmen	Expected No. of Inoperative Machines	Expected cost/hour of Inoperative Machines	Cost/hour of Repairmen	Total expected cost/hour
0	10.0	\$3500.00	\$0	\$3500.00
1	5.092	\$1782.17	\$30.00	\$1812.17
2	2.404	\$841.30	\$60.00	\$901.30
3	1.804	\$631.50	\$90.00	\$721.50
4	1.689	\$591.28	\$120.00	\$711.28
5	1.670	\$584.38	\$150.00	\$734.38

Thus, it appears that optimum number of repairmen is 4.

An example LINGO model for computing this table is as follows:

```

! Machine repair
SETS:
  NREP/1..5/:          ! Consider 5 possible no. of repair persons;
  NDOWN, ! Expected no. of down machines;
  CPERHR, ! Expected cost/hour of down machines;
  TCOST; ! Total expected cost/hour;
ENDSETS
! For each configuration, compute the performance-
@FOR( NREP( I ):
  NDOWN( I) = @PFS( NMACH * RTIME / UPTIME, I, NMACH);
  CPERHR( I) = CM * NDOWN( I);
  TCOST( I) = CPERHR( I) + CR * I;
);
! The input data;
NMACH = 10;
RTIME = 1;
UPTIME = 5;
CR = 30;
CM = 350;
END

```

Part of the solution is:

Variable	Value
TCOST(1)	1812.173
TCOST(2)	901.3025
TCOST(3)	721.5043
TCOST(4)	711.2829
TCOST(5)	734.3842

A model similar to the machine repairman has been used by Samuelson (1999) to analyze predictive dialing methods in an outbound call center. In a predictive dialing system, an automatic dialer may start dialing the next client to be contacted even before there is an agent available to talk to the client. It takes anywhere from 10 to 30 seconds to dial a number and have the person dialed answer the phone. So, the automatic dialing is done in the anticipation that an agent will become available by the time that a called party answers the phone. An automatic dialer can detect a busy signal or a call that is not answered, and can move on to dial the next number. Samuelson (1999) indicates that a good predictive dialer can increase the agent talk time (i.e., utilization) to 95% from less than 80%. The manager of a predictive dialer has at least two decision variables in controlling the predictive dialer: a) how many additional lines to use, beyond the number of agents, for dialing, and b) the delay time before starting dialing on a line once it becomes available. These two decisions can be fit into the machine repairman as follows. The number of agents equals the number of repairmen. The number of lines total is the population size. The up time is *the delay time before initiating dialing + the dialing time + time to answer*.

18.4.5 Selection of a Processor Type via the M/G/1 Model

You are about to install an ATM (Automated Teller Machine) at a new location. You have a choice between two machines. The type A is a highly automated machine with a mean time to process a transaction of 3 minutes with a standard deviation of 4.5 minutes. The type M machine is less automated. It has a mean processing time of 4 minutes with a standard deviation of 1 minute. The expected arrival rate is 10 customers/hour at the location in question. Which machine has a lower expected waiting time? Which machine has a lower expected time in system?

There is a simple expression for the expected waiting time in a system with a single server for which arrivals occur in a Poisson fashion and service times have a general distribution. If:

R = mean arrival rate,
 T = mean service time,
 SD = the standard deviation in service times, and
 EW = expected waiting time,

then:

$$EW = R * (T * T + SD * SD) / [2 * (1 - R * T)].$$

The following LINGO model illustrates:

```

! Single server queue with Poisson(Markovian) arrivals
  and General service distribution, so-called M/G/1 queue;
DATA:
R = .1666667; ! Arrival rate in minutes(10/hour);
T = 3;        ! Mean service time in minutes;
SD = 4.5;     ! Standard deviation in service time;
ENDDATA
! Compute load( = Prob{ wait > 0});
RHO = R*T;
! Expected waiting time;
EW = R*( SD * SD + T * T)/(2*(1-RHO));
! Expected time in system;
ET = EW + T;
! Expected number waiting;
EN = R * EW;
! Expected number in system;
ES = R * ET;

```

The solution is:

Variable	Value
R	0.1666667
T	3.000000
SD	4.500000
RHO	0.5000001
EW	4.875002
ET	7.875002
EN	0.8125005
ES	1.312501

To evaluate the slower, but less variable server, we change the data section to:

```

DATA:
R = .1666667; ! Arrival rate in minutes(10/hour);
T = 4;        ! Mean service time in minutes;
SD = 1;       ! Standard deviation in service time;
ENDDATA

```

Now, the solution is:

Variable	Value
R	0.1666667
T	4.000000
SD	1.000000
RHO	0.6666668
EW	4.250003
ET	8.250003
EN	0.7083339
ES	1.375001

This is interesting. Due to the lower variability of the second server, the expected wait time is lower with it. The first server, however, because it is faster, has a lower total time in system, ET. There are some situations in which customers would prefer the longer expected time in system if it results in

a lower expected waiting time. One such setting might be a good restaurant. A typical patron would like a low expected wait time, but might actually prefer a long leisurely service.

18.4.6 Multiple Server Systems with General Distribution, M/G/c & G/G/c

There is no simple, “closed form” solution for a system with multiple servers, a service time distribution that is non-exponential, and positive queue space. Whitt (1993), however, gives a simple approximation. He gives evidence that the approximation is usefully accurate. Define:

$$\begin{aligned}
 SCVA &= \text{squared coefficient of variation of the interarrival time distribution} \\
 &= (\text{variance in interarrival times}) / (\text{mean interarrival time squared}) \\
 &= (\text{variance in interarrival times}) * R * R, \\
 SCVT &= \text{squared coefficient of variation of the service time distribution} \\
 &= (\text{variance in service times}) / (\text{mean service time squared}) \\
 &= (\text{variance in service times}) / (T * T). \\
 EWM(R, T, S) &= \text{expected waiting time in an M/M/c system with arrival rate R,} \\
 &\quad \text{expected service time T, and S servers.}
 \end{aligned}$$

The approximation for the expected waiting time is then:

$$\begin{aligned}
 &EWG(R, T, S, SCVA, SCVT) \\
 &= EWM(R, T, S) * (SCVA + SCVT) / 2.
 \end{aligned}$$

Note that for the exponential distribution, the coefficient of variation is one. It is fairly easy to show that this approximation is in fact exact for M/G/1, M/M/c, M/G/∞, and when the system becomes heavily loaded.

Example

Suppose arrivals occur in a Poisson fashion at the rate of 50/hour (i.e., .8333333 per minute), there are three servers, and the service time for each customer is exactly three minutes. A constant service time implies that the service time squared coefficient of variation (*SCVT*) equals 0. Poisson arrivals implies that the squared coefficient of variation of interarrival times (*SCVA*) equals 1. The model is:

```

! Compute approximate statistics for a (QGGC)
  multi-server system with general arrivals,
  and general service time distribution;
DATA:
  R = .8333333; ! Mean arrival rate;
  T = 3;        ! Mean service time;
  S = 3;        ! Number of servers;
  SCVA = 1;     ! Squared coefficient of variation
                of interarrival times;
  SCVT = 0;     ! Squared coefficient of variation
                of service times;

ENDDATA
! The model;
! Average no. of busy servers;
  LOAD = R * T;
! Probability a given call must wait;
  PWAIT = @PEB( LOAD, S);
! Conditional expected wait, i.e., given must wait;
  WAITCND = T/( S - LOAD);
! Unconditional expected wait;
  WAITUNC = PWAIT * WAITCND;
! Unconditional approximate expected wait for
  general distribution;
  WAITG = WAITUNC * (SCVA + SCVT)/2;

```

The solution is:

Variable	Value
R	0.8333333
T	3.000000
S	3.000000
SCVA	1.000000
SCVT	0.000000
LOAD	2.500000
PWAIT	0.7022471
WAITCND	5.999999
WAITUNC	4.213482
WAITG	2.106741

Thus, the approximate expected wait time is about 2.1067. Later we will show that the expected wait time can in fact be calculated exactly as 2.15. So, the approximation is not bad.

18.5 Critical Assumptions and Their Validity

The critical assumptions implicit in the models discussed can be classified into three categories:

- 1) Steady state or stationarity assumptions.
- 2) Poisson arrivals assumption.
- 3) Service time assumptions.

The steady state assumption is that the system is not changing systematically over time (e.g., the arrival rate is not changing over time in a cyclical fashion). Further, we are interested in performance only after the system has been operating sufficiently long, so that the starting state has little effect on the long run average. No real system strictly satisfies the steady state assumption. All systems start up at some instant and terminate after some finite time. Arrival rates fluctuate in a predictable way over the course of a day, week, month, etc. Nevertheless, the models discussed seemed to fit reality quite well in many situations in spite of the lack of true stationarity in the real world. A very rough rule of thumb is that if the system processing capacity is b customers/minute and the arrival rate is c customers/minute, then the steady state formulae apply approximately after $1/(b - c)$ minutes. This corresponds roughly to one "busy period."

The models discussed have assumed that service times are either constant or exponential distributed. Performance tends to be relatively insensitive to the service time distribution (though still dependent upon the mean service time) if either the system is lightly loaded or the available waiting space is very limited. In fact, if there is no waiting space, then to compute the distribution of number in system the only information needed about the service time distribution is its mean.

18.6 Networks of Queues

Many systems, ranging from an office that does paperwork to a manufacturing plant, can be thought of as a network of queues. As a job progresses through the system, it successively visits various service or processing centers. The main additional piece of information one needs in order to analyze such a system is the routing transition matrix, that is, a matrix of the form:

$$P(i,j) = \text{Prob}\{\text{a job next visits processing center } j \mid \text{given that it just finished at center } i\}.$$

Jackson (1963) proved a remarkable result, essentially that if service times have an exponential distribution and arrivals from the outside arrive according to a Poisson process, then each of the individual queues in a network of queues can be analyzed by itself. The major additional piece of information that one needs to analyze a given work center or station is the arrival rate to the station. If we define $REXT(j)$ = arrival rate to station j from the outside (or external) world, and $R(j)$ = the arrival rate at station j both from inside and outside, then it is fairly easy to show and also intuitive that the $R(j)$ should satisfy:

$$R(j) = REXT(j) + \sum_i R(i) * P(i,j).$$

The following LINGO model illustrates how to solve this set of equations and then solve the queuing problem at each station:

```

! Jackson queuing network model(qjacknet);
SETS:
  CENTER: S, T, REXT, R, NQ, LOAD;
  CXC( CENTER, CENTER): P;
ENDSETS
DATA:
! Get center name, number of servers,
  mean service time and external arrival rate;
CENTER, S, T, REXT =
C1      2   .1   4
C2      1   .1   1
C3      1   .1   3;
! P(i,j) = Prob{ job next goes to i| given just
           finished at j};
P = 0   .6   .4
    .1   0   .4
    .3   .3   0;
ENDDATA
! Solve for total arrival rate at each center;
@FOR( CENTER( I):
  R( I) = REXT( I) + @SUM( CENTER( J): R( J) * P( I, J));
);
! Now solve the queuing problem at each center;
@FOR( CENTER( I):
!  LOAD( I) = load on center I;
  LOAD( I) = R( I) * T( I);
!  Expected number at I = expected number waiting
  + expected number in service;
  NQ( I) = ( LOAD( I)/( S( I) - LOAD( I)))
           *@PEB( LOAD( I), S( I)) + LOAD( I);
!  @PEB() = Prob{ all servers are busy at I};
);
! Expected time in system over all customers;
WTOT = @SUM( CENTER: NQ)/@SUM( CENTER: REXT);

```

Part of the solution is:

Variable	Value
WTOT	0.6666667
R(C1)	10.00000
R(C2)	5.000000
R(C3)	7.500000
NQ(C1)	1.3333333
NQ(C2)	1.000000
NQ(C3)	3.000000
LOAD(C1)	1.000000
LOAD(C2)	0.5000000
LOAD(C3)	0.7500000

18.7 Designer Queues

In preceding sections, we gave some “canned” queuing models for the most common waiting line situations. In this section, we present details on the calculations behind the queuing models. Thus, if you want to design your own queuing system that does not quite match any of the standard situations, you may be able to model your situation using the methods here.

18.7.1 Example: Positive but Finite Waiting Space System

A common mode of operation for an inbound call center is to have, say 20 agents, but say, 30 phone lines. Thus, a caller who finds a free phone line but all 20 agents busy, will be able to listen to soothing music while waiting for an agent. A caller who finds 30 callers in the system will get a busy signal and will have to give up.

First, define some general parameters:

- r = arrival rate parameter. For the infinite source case, $1/r$ = mean time between successive arrivals. For the finite source case, $1/r$ = mean time from when a given customer finishes a service until it next requires service again (i.e., $1/r$ = mean up time),
- T = mean service time,
- S = number of servers,
- M = number of servers plus number of available waiting spaces.

We want to determine:

$$P_k = \text{Prob} \{ \text{number customers waiting and being served} = k \}$$

If there are S servers, and M total lines or spaces, then the distribution of the number in system, the P_k , satisfy the set of equations:

$$\begin{aligned} P_k &= (rT/k)P_{k-1} \text{ for } k = 1, 2, \dots, S \\ &= (rT/S)P_{k-1} \text{ for } k = S + 1, S + 2, \dots, M \end{aligned}$$

and

$$P_0 + P_1 + \dots + P_M = 1.$$

Here is a model that solves the above set of equations:

```

! M/M/c queue with limited space (qmmcf);
DATA:
! Number of servers;
  S = 9;
! Total number of spaces;
  M = 12;
! Arrival rate;
  R = 4;
! Mean service time;
  T = 2;
ENDDATA
SETS:
  STATE/1..500/: P;
ENDSETS
! The basic equation for a Markovian(i.e., the time
  til next transition has an exponential distribution) system,
  says:(expected transitions into state k per unit time)
    = (expected transitions out of state k per unit time);
! For state 1( P0 = prob{system is empty});
  P( 0) * R + P( 1) * S/T = ( R + S/T) * P( 0);
! Remaining states with idle servers;
@FOR( STATE( K) | K #GT# 1 #AND# K #LT# S:
  P( K - 1) * R + P( K) * S/T = ( R + S/T) * P( K)
  );
! States with all servers busy;
@FOR( STATE( K) | K #GE# S #AND# K #LT# M:
  P( K - 1) * R + P( K) * S/T = ( R + S/T) * P( K)
  );
! All-full state is special;
  P( M - 1) * R = (S/T) * P( M);
! The P(k)'s are probabilities;
  P( 0) + @SUM( STATE( K) | K #LE# M: P( K)) = 1;
! Compute summary performance measures;
! Fraction lost;
  FLOST = P( M);
! Expected number in system;
  EN = @SUM( STATE( K) | K #LE# M: K * P( K));
! Expected time in system for those who enter;
  ET = EN / ( R * (1-FLOST));
! Expected wait time for those who enter;
  EW = ET - T;

```

The solution is:

Variable	Value
N	9.000000
M	12.000000
R	4.000000
T	2.000000
P0	0.3314540E-03
FLOST	0.8610186E-01
EN	7.872193
ET	2.153466
EW	0.153466
P(1)	0.2651632E-02
P(2)	0.1060653E-01
P(3)	0.2828407E-01
P(4)	0.5656815E-01
P(5)	0.9050903E-01
P(6)	0.1206787
P(7)	0.1379185
P(8)	0.1379185
P(9)	0.1225942
P(10)	0.1089727
P(11)	0.9686459E-01
P(12)	0.8610186E-01

This model has three extra waiting spaces or lines beyond the nine servers. The fraction demand lost is 0.08610186. By comparison, if there were no extra lines, the fraction lost would be more than twice as much, 0.1731408.

The above model is an example of *balking*. A prospective customer is said to balk if the customer decides to not join the queue because the queue is too long. It is a common problem in systems where the queue is visible (e.g., automotive fuel filling stations). More generalized forms of balking can be modeled using methods of this chapter. One such form might be that an arriving customer balks with a probability that is increasing in the length of the queue.

A phenomenon similar to balking is *reneging*. A customer in the waiting queue is said to renege if she departs the waiting queue before having received service. For example, at internet websites it is not uncommon for more than 50% of customers to abandon their “shopping carts” before getting to the checkout step. Again, reneging behavior can be easily modeled using the methods of this section by having a reneging rate that is, say proportional to the number waiting.

18.7.2 Constant Service Time. Infinite Source. No Limit on Line Length

The special case when the service time is a constant can be solved numerically. If the service time is a constant T , then we can exploit the fact that over any interval of time of length T : a) all customers in service at the beginning of the interval will have finished at the end, and b) the number of arrivals during the interval has a Poisson distribution. Define the Poisson probabilities:

$$\begin{aligned} a_k &= e^{-(rT)}(rT)^k/k! \quad \text{for } k = 0, 1, 2, \dots \\ &= a_{k-1}(rT)/k. \end{aligned}$$

The P_k satisfy the equations:

$$\sum_{k=0}^{\infty} P_k = 1$$

and if S is the number of servers:

$$P_k = \sum_{j=0}^S a_k P_j + \sum_{j=S+1}^{k+S} P_j a_{k-j+S} \quad \text{for } k = 0, 1, 2, \dots$$

18.7.3 Example Effect of Service Time Distribution

A firm uses 3 servers in parallel to process tasks that arrive at the mean rate of 50 per hour. The mean time to service a task is 3 minutes (.05 hours). The service time distribution is exponential.

The firm is considering switching to a more systemized processing approach in which there is no variability in the service time (i.e., every task takes exactly 3 minutes). Will this switch substantially reduce the average number in system?

The following is a LINGO model for solving these equations:

```

! Queue with constant service time (qmdc);
DATA:
! Arrival rate per minute;
  R = .833333;
! Service time in minutes;
  T = 3;
! Number of servers;
  S = 3;
ENDDATA
SETS:
  STATE/1..35/: A, P;
ENDSETS

! Probabilities must sum to 1;
@SUM( STATE: P) = 1;
  RHO = R * T;
! J and K will correspond to a state-1;
! Calculate probability of K-1 arrivals during a service time;
  A(1) = @EXP( - RHO);
@FOR( STATE(K)| K #GT# 1:
  A(K) = A(K-1) * RHO/(K-1);
  );
  NLAST = @SIZE( STATE);
  @WARN(" S too large for approximation", A(NLAST) #GT# .1);
! Transition equations:
  Probability of having K-1 in system T minutes from now
  = Prob{ all in system finished and K-1 arrived} + Prob{ S finished
and just the proper number arrived to bring number in system back up
to K-1};
@FOR( STATE( K)| K #LT# @SIZE(STATE):
  P( K) = @SUM( STATE( J)| J #LE# S: A( K) * P( J))
  + @SUM( STATE( J)| J #GT# S #AND# J #LE# K + S: P(J)*A(K-
J+S+1));
  );
! Because of the extra normalizing equation, we can drop
one transition equation above;
! Compute average number in system;
  AVGNSYS = @SUM( STATE( K): (K-1)* P(K));
! By Little's equation, average time in system;
  AVGTSYS = AVGNSYS/ R;
! Average number waiting;
  AVGNWTN = AVGNSYS - RHO;

```

Part of the solution is:

Variable	Value
RHO	2.499999
NLAST	35.00000
AVGNSYS	4.291565
AVGTSYS	5.149880
AVGNWTN	1.791566
P(1)	0.3936355E-01
P(2)	0.1102164
P(3)	0.1615349
P(4)	0.1684308
P(5)	0.1438250
P(6)	0.1097549
P(7)	0.7924944E-01
P(8)	0.5598532E-01
P(9)	0.3930554E-01
P(10)	0.2757040E-01
P(11)	0.1934223E-01
P(12)	0.1357152E-01
P(13)	0.9522611E-02

It is of interest to compare this result with the case of exponentially distributed service times:

	Exponential Service Distribution	Constant
Average No. in System	6.01	4.29
Average No. Waiting	3.51	1.79

Thus, there is a noticeable improvement associated with reducing the variability in service time. In fact, in a heavily loaded system, reducing the variability as above will reduce the expected waiting time by a factor of almost 2.

18.8 Problems

1. The Jefferson Mint is a Philadelphia based company that sells various kinds of candy by mail. It has recently acquired the Touted-de-Suite Candy Company of New Orleans and the Amber Dextrose Candy Company of Cleveland. The telephone has been an important source of orders for all three firms. In fact, during the busiest three hours of the day (1 pm to 4 pm), Jefferson has been taking calls at the rate of .98 per minute, Touted-de-Suite at the rate of .65 calls per minute, and Dextrose at the rate of .79 calls per minute. All three find that on average it takes about three minutes to process a call.

Jefferson would like to examine the wisdom of combining one or more of the three phone order taking centers into a single order taking center in Philadelphia. This would require a phone line from New Orleans to Philadelphia at a cost of \$170 per day and/or a phone line from Cleveland to Philadelphia at a cost of \$140 per day. A phone order taker costs \$75 per day. Regardless of the configuration chosen, the desired service level is 95%. That is, at least 95% of the calls should be answered immediately, else it is considered lost. This requirement is applicable to the busiest time of the day in particular. This is considered reasonable for the kind of semi-impulse buying involved. Note that only one phone line is needed to connect two cities. This dedicated line can handle several dozen conversations simultaneously.

- a) The New Orleans office could be converted first. What are the expected savings per day of combining it with the Philadelphia office?
 - b) What is your complete recommendation?
 - c) The Cleveland office has been operating with four order takers. How might you wish to question and possibly adjust the Cleveland call data?
2. Reliability is very important to a communications firm. The Exocom firm has a number of its large digital communication switches installed around the country. It is concerned with how many spares it should keep in inventory to quickly replace failed switches in the field. It estimates that failures will occur in the field at the rate of about 1.5 per month. It is unattractive to keep a lot of spares because the cost of each switch is \$800,000. On the other hand, it is estimated that, if a customer is without his switch, the cost is approximately \$8,000 for each day out, including weekends. This cost is borne largely by Exocom in the form of penalties and lost good will. Even though a faulty switch can be replaced in about one hour, (once the replacement switch is on site), it takes about one half month to diagnose and repair a faulty switch. Once repaired, a switch joins the spares to hold. Exocom is anxious to get your advice because, if no more money need be invested in spares, then there are about four other investment projects waiting in the wings, which pass the company's 1.5% per month cost of capital threshold. What is your recommendation?

3. Below is a record of long-distance phone calls made from one phone over an interval of time.

<u>DATE</u>	<u>DESTINATION</u>		<u>NUMBER</u>	<u>DATE</u>	<u>DESTINATION</u>		<u>NUMBER</u>
	<u>CITY</u>	<u>STATE</u>	<u>MINUTES</u>		<u>CITY</u>	<u>STATE</u>	<u>MINUTES</u>
03/04	MICHIGANCY	IN	0.4	03/21	NEW YORK	NY	12.6
03/07	PHILA	PA	3.1	03/21	PRINCETON	NJ	2.0
03/07	LAFAYETTE	IN	3.9	03/21	PRINCETON	NJ	0.2
03/07	OSSINING	NY	1.4	03/21	PRINCETON	NJ	0.3
03/07	LAFAYETTE	IN	2.8	03/21	PRINCETON	NJ	0.3
03/08	LAFAYETTE	IN	2.8	03/25	SANTA CRUZ	CA	1.4
03/08	SOSAN FRAN	CA	2.0	03/25	FORT WAYNE	IN	0.9
03/08	PHILA	PA	0.9	03/27	SANTA CRUZ	CA	0.9
03/11	BOSTON	MA	5.1	03/27	SANTA CRUZ	CA	8.1
03/11	NEW YORK	NY	3.1	03/27	SOSAN FRAN	CA	8.2
03/15	MADISON	WI	0.3	03/27	CHARLOTSVL	VA	0.7
03/19	PHILA	PA	3.6	03/28	CHARLOTSVL	VA	8.4
03/20	PALO ALTO	CA	4.7	03/28	NEW YORK	NY	0.8
03/20	PALO ALTO	CA	9.2	03/29	NEW YORK	NY	1.7

<u>DATE</u>	<u>DESTINATION</u>		<u>NUMBER</u>	<u>DATE</u>	<u>DESTINATION</u>		<u>NUMBER</u>
	<u>CITY</u>	<u>STATE</u>	<u>MINUTES</u>		<u>CITY</u>	<u>STATE</u>	<u>MINUTES</u>
03/29	BOSTON	MA	0.6	04/16	CAMBRIDGE	MA	0.9
04/01	HOUSTON	TX	1.1	04/18	ROCHESTER	NY	1.3
04/01	BOSTON	MA	10.6	04/19	PALO ALTO	CA	16.1
04/01	BRYAN	TX	1.4	04/22	ROCHESTER	NY	1.7
04/01	PEORIA	IL	1.0	04/23	CHARLSTON	IL	0.7
04/02	SANTA CRUZ	CA	5.5	04/24	CHARLSTON	IL	6.4
04/03	HOUSTON	TX	1.4	04/24	WLOSANGLS	CA	3.0
04/03	PEORIA	IL	2.3	04/24	NEW YORK	NY	5.1
04/09	NEW YORK	NY	1.1	04/24	FORT WAYNE	IN	0.9
04/11	LOS ALTOS	CA	5.5	04/24	PORTAGE	IN	2.2

- How well does a Poisson distribution (perhaps appropriately modified) describe the call per day behavior?
- How well does an exponential distribution describe the number of minutes per call?
- In what year were the calls made?

Design & Implementation of Optimization-Based Decision Support Systems

*I don't want it perfect, I want it Thursday.
-John Pierpont Morgan*

19.1 General Structure of the Modeling Process

The overall modeling process is one of:

- 1) Determining the need for a model.
- 2) Developing the model.
- 3) Implementing the model.

One should not skip over step (1) in one's enthusiasm to use a fancy model. Some questions to ask before deciding to use a model are:

- a) Are the expected savings from using the model greater than the cost of developing and implementing the model?
- b) Is there sufficient time to do (2) and (3) before the recommendation is needed?
- c) Is it easier to do an experiment on the real system than to build a model? Sometime ago a question arose in a telephone company about the effect of serving certain telephone calls for information arising in city A from a central facility in city B, rather than from the existing facility in A. It was more simple to make a five minute wiring change to see what happened, than to construct an accurate statistical model. Similarly, Banks and Gibson (1997) describe a situation in which one fast food restaurant chain built a detailed model to evaluate the effect of a second drive-up window. In less time, a competitor tested the same idea by stationing a second person in the drive-up lane with a remote hand-held terminal and voice communication to the inside of the restaurant.
- d) Do we have the input data needed to make plausible use of the model?

If the purpose of the model is to do a one-time analysis (e.g., to decide whether or not to make a certain investment), then step (3) will be relatively less laborious.

19.1.1 Developing the Model: Detail and Maintenance

Whether the model is intended for a one-time study or is to be used regularly has some influence on how you develop the model. If the model is to be used regularly, then you want to worry especially about the following:

Problem: The real world changes rapidly (e.g., prices, company structure, suppliers). We must be able to update the model just as fast.

Resolution: There are two relevant philosophies.

- 1) Keep worthless detail out of the model, follow the KISS (Keep It Simple, ...) admonition.
- 2) Put as much of the model into data tables rather than hard coded into the model structure.

19.2 Verification and Validation

The term *verification* is usually applied to the process of verifying that the model as implemented is actually doing what we think it should. Effectively, verification is checking the model has no unintentional "bugs". *Validation* is the process of demonstrating that all the approximations to reality intentionally incorporated in the model are tolerable and do not sully the quality of the results from the model. Stated simply, verification is concerned with "solving the equations right", and validation is concerned with "solving the right equations", see Roache (1998). Several general approaches for verifying a model are to:

- i) check the model results against solved special cases,
- ii) check the model results against known extreme cases,
- iii) check the model results on small examples that can be solved by hand,
- iv) check that model results change in the proper direction as model inputs are changed (e.g., if the price of a raw material increases, we should not buy more of it), and
- v) check that the model handles invalid cases robustly.
- vi) if there are multiple dimensions, e.g. products, suppliers, customers, time periods, etc., the set of tests cases should give good coverage of all combinations.

Many of the methods used for verifying the quality of computer software apply equally well to verifying large models. For example, a useful concept in testing of computer software is that of "coverage" by the test. A good test for software should exercise or cover all sections of code in a software program. Similarly, good test data for a model should exercise all features of the model. If a model allows up to N different products, say, one should have test data for the cases of: just 1 product (e.g., see (i) above); exactly N products; an intermediate number of products, and more than N products. Elaborating on (vi) above, we might want to have tests of all pairs of combination of: 1 and N products, 1 and M suppliers, 1 and P periods, etc.

19.2.1 Appropriate Level of Detail and Validation

Validation should begin with understanding the real world to be modeled. A common problem is the people who are willing to speak most authoritatively about the process to be modeled are not always the most informed. A good rule of thumb is always to check your "facts" with a second source. Rothstein (1985) mentions, in a conversation with a vice president of a major airline, the vice president assured him the airline did not engage in overbooking of any kind. A short time later, in a discussion with operating personnel, he learned in fact the airline had a sophisticated overbooking system used everywhere in that airline.

If unimportant details are kept out of the model, the model should be not only easier to modify, but also easier to use.

Example. In developing a long-range ship scheduling model, a question of appropriate unit of time arose. Tides follow a roughly 13-hour cycle and this is an important consideration in the scheduling of ships into shallow ports. Deep draft ships can enter a shallow port only at high tide. Thus, in developing a multiperiod model for ship scheduling, it appeared 13 hours should be the length of a period.

However, we found ship travel times were sufficiently random, so scheduling to the day was satisfactory. Thus, to model a month of activity, 30 time periods, rather than about 60, was satisfactory. Halving the number of periods greatly simplified the computations. The moral perhaps is that, when it comes to incorporating detail into the model, a little bit of selective laziness may be a good thing.

If there is an art to modeling, this is it: identifying the simplifications or approximations that can be made without sacrificing the useful accuracy of the model. Simplifying approximations can be categorized roughly as follows:

- 1) *Functional* - Use a linear function to approximate a slightly nonlinear one.
- 2) *Aggregation*
 - (2.1) *Temporal* aggregation - All events occurring during a given day (or week, month, etc.) are treated as having occurred at the end of the day.
 - (2.2) *Cross-sectional* aggregation - All customers in a given mail code region are lumped together to be treated as one large customer. In a consumer products firm, all detergents are treated as a single product.
- 3) *Statistical* - Replace a random variable by its expectation. For example, even though future sales are a random variable, most planners use a single number forecast in planning.
- 4) *Decomposition* - If a system is overwhelming in its complexity, then decomposition is an approach that may be useful for simplifying the structure. Under this approach, a sequence of models are solved, each nailing down more detail of the complete solution.

Rogers, Plante, Wong, and Evans (1991) give an extensive survey of techniques for aggregation in optimization problems. The steps in using an approximate model can be summarized as follows:

- 1) Obtain detailed input data.
- 2) Derive the approximate (hopefully small) model.
- 3) Solve the approximate model.
- 4) Convert the solution of the approximate model back to the real world.

The difficult step is (4). The worst thing that can happen is it is impossible to convert the approximate solution back to a feasible real world solution.

19.2.2 When Your Model & the RW Disagree, Bet on the RW

As part of the validation process, you compare the output of your model with what happened in the real world (RW). When there is a discrepancy, there are two possibilities: (a) People in the RW are not behaving optimally and you have an opportunity to make some money by using your model; or (b) your model still has some flaws.

Black (1989) described the situation quite well while he was trying to validate an option pricing model:

“We estimated the volatility of the stock for each of a group of companies... We noticed that several warrants looked like very good buys. The best buy of all seemed to be National General... I and others jumped right in and bought a bunch... Then a company called American Financial announced a tender offer for National General... the tender offer had the effect of sharply reducing the value of the warrants... In other words, the market knew something that our formula didn’t know... and that’s why the warrants seemed so low in price.”

19.2.3 Should We Behave Non-Optimally?

One of the arts of modeling is knowing which details to leave out of the model. Unfortunately, one of the first kinds of details left out of a model are the things that are difficult to quantify. One kind of difficult-to-quantify feature is the value of information. There are a number of situations where, if value of information is left out of the model, one may wish not to implement exactly an optimal solution. The following are some examples:

An optimal inventory model may recommend using a very large order size. If we use a smaller order size, however, we will be giving more timely information to our supplier about retail demand for his product. In between orders, the supplier has no additional information about how his product is selling. In the extreme, if we used an order size of 1, then the supplier would have very up-to-date information about retail demand and could do better planning.

A firm that extends credit to customers may occasionally wish to behave nonoptimally in order to gain additional information. If the firm’s initial credit optimization model says never give credit to customers with profile X , the firm should occasionally extend credit to X in order to have up-to-date information on customers with that profile.

In addition to occasionally behaving nonoptimally to gain or reveal additional information, one may also wish to behave nonoptimally in order not to reveal too much information. Any good poker player knows one must occasionally bluff by placing a large bet, even though the odds associated with the given hand do not justify a large bet. If other players know you never bluff, then they will drop out every time you place a large bet.

There was a rumor at the end of World War II that Great Britain allowed the bombing of Coventry on one occasion. That is because, if the British had sent up a large fleet of fighters in advance to meet the incoming German bombers, the Germans would have known the British had broken the German communications codes.

19.3 Separation of Data and System Structure

There are two reasons for separating data from model structure:

- a) It allows us to adjust the model easily and quickly to changes in the real world,
- b) The person responsible for making day-to-day changes in the data need not be familiar with the technical details of the model structure.

A flexible system is table driven. In powerful systems such as LINGO and *What’sBest!*, factors such as interest rates can be input at a single place by a clerk, even though they appear numerous places in the model structure.

19.3.1 System Structure

In the typical case, a model will be used regularly (e.g., weekly in an operational environment). In this case, the model system can be thought of as having the structure shown in Figure 19.1:

Figure 19.1 System Structure

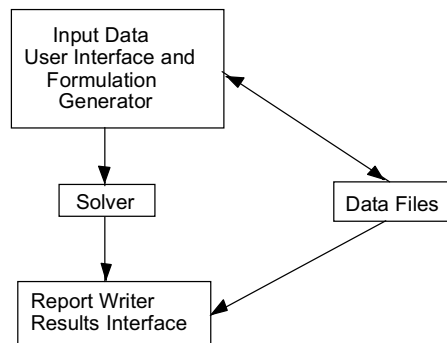

Notice there is a double-headed arrow between the data files and the formulation generator. This is because the generator may obtain parameters such as capacities from the data files. There is an arrow from the data files to the report writer because there are data, such as addresses of customers, that are needed for the output reports but are not needed in the formulation. The success of spreadsheet programs, such as Lotus 1-2-3, is due in part to the fact they incorporate all the above components in a relatively seamless fashion.

19.4 Marketing the Model

It is important to keep in mind: Who will be the users/clients? Frequently, there are two types of clients in a single organization:

- 1) The Model champion (e.g., a CEO),
- 2) Actual user (e.g., a foreman working 12 hours/day and whose major concern is getting the work out and meeting deadlines).

Client (1) will commit to model development based on expected profit improvement. Client (2) will actually use the model if it simplifies his/her life. He may get fired if he misses a production deadline. There is a modest probability of a raise if he improves profitability and takes the trouble to document it. Thus, for client (2), the input and output user interfaces are very important.

19.4.1 Reports

A model has an impact largely via the reports it produces. If a standard report already exists in the organization, try to use it. The model simply puts better numbers in it.

Example. An LP-based scheduling system was developed for shoe factories. It was a success in the first factory where it was tried. Production improved by about 15%. The system never “got off the ground” in a second factory. The reason for the difference in success was apparently as follows. The first factory had an existing scheduling report or work order. This report was retained. The results of the LP scheduling model simply put better numbers in it. The second factory had been using an informal scheduling system. The

(c)

Finished Goods Summary				
Product	Beginning Inventory	Goods Produced	Total Required	Surplus

19.4.1.2 Dimensional View of Reports

A more mechanical view of report generation is to take a dimensional view of a system (i.e., a problem and its solution have a number of dimensions). Each report is a sort and summary by dimensions.

Example: *Multiperiod Shipping*

Dimensions: Origins, destinations, time periods. The major decision variables might be of the form X_{ijt} , where X_{ijt} is the number of tons to be shipped from supplier i , to customer j in time period t . The types of reports might be:

Supplier's Report: Sorted by origin, time, destination (or summed over destination).

Shipping Manager's Report: Sorted by time, origin, destination.

Customer's Report: Sorted by destination, time, origin (or perhaps summed over origin).

Most spreadsheets and database systems have multi-level sorting capability.

19.4.1.3 Report Details/Passing the Snicker Test

Results should be phrased in terms the user finds easy to use.

For example, reporting a steel bar should be cut to a length of 58.36 inches may cause snickers in some places because "everybody knows" this commodity (like U.S. stock prices) is measured in multiples of 1/8 inches, or dollars, as the case may be. So, it would be better to round the result to 58.375 inches or, even better, report it as 58 and 3/8 inches.

Other examples: Dates should be reported not only in day of the month (taking into account leap years), but also day of the week. Different parts of the world use different formats for displaying dates (e.g., 14 March 1991 or 3/14/1991). Use a format appropriate for the location where used.

Example: *Vehicle Routing/Passing the Snicker Test*

Customers are grouped into trips, so the same vehicle serves customers on the same trip. The actual model decomposed the problem into two phases:

- (1) Allocate to trips ← Big savings here.
- (2) Sequence each trip ← Users notice this the most.

If your system does an excellent job of allocating customers to trips (where the big savings exist), but does not always get the optimal sequence of customers within a trip, users may

notice the latter weakness. Even though there may be no big savings possible by improving the sequence, users may have less faith in the system because of this small weakness.

19.4.1.4 Models Should Always Have Feasible Solutions

In a large model where the input data are prepared by many people, there may be no assurance the data are perfectly consistent. For example, production capacity as estimated by the production department may be insufficient to satisfy sales forecasts as estimated by the marketing department. If the model has a constraint that requires production to equal forecasted sales, then there may be no feasible solution. The terse message “No feasible solution” is not very helpful.

A better approach is to have in the model a *superworker* or *superfacility* that can make any product at infinite speed, but at a rather high cost. There will always be a feasible solution although some parts of the solution may look somewhat funny.

Another device is to allow *demand to be backlogged* at a high cost.

In each case, the solution will give sensible indications of where one should install extra capacity or cut back on projected sales, etc.

A model may be fundamentally good, but incomplete in certain minor details. As a result, some of its recommendations may be slightly, but blatantly, incorrect.

For example, in reality almost every activity has a finite upper bound.

Similarly, there may be obvious *bounds on the dual* prices of certain resources. For example, if land is a scarce resource in the real world, then its dual price should never be zero. You should *include sellout or buy activities* corresponding to such things as renting out excess land to put lower and upper bounds on dual prices.

19.4.1.5 “Signing Off” on System Structure

If a prospective model (a) is likely to be complicated and (b) the group that will use the model is distinct from the group that will design the model, then it will be worthwhile to have beforehand a written document describing exactly what the model does. Effectively, the “User’s Manual” is written before the system is implemented. The prospective users should “sign off” on the design (e.g., by providing a letter that says “Yes, this is what we want *and we will accept* if it provides this”).

This document might include the following:

- a) Form in which input will be provided.
- b) Form in which output will be provided.
- c) Test data sets that must be successfully processed. The model will be accepted if and only if these are satisfied.

19.4.2 Report Generation in LINGO

The default report format in LINGO is the three column: Variable, Value, Reduced Cost report format. You can generate somewhat arbitrary customized reports by using several functions available in a DATA section in LINGO. The functions are:

`@TEXT()` = output function. Allows you to specify a line to be output. If `@TEXT()` has no argument, then the line is output to the terminal display, else it is output to the filename listed in the argument as in `@TEXT(myfile.txt) =`.

`@WRITEFOR` output looping function. Analogous to the `@FOR` function in a model, it specifies looping over sets when generating output.

`@WRITE()`. Used for outputting a single line.

`@NEWLINE(n)` inserts n newlines or carriage returns in the output.

`@FORMAT(field, value)` specifies a field format, e.g., number of characters, and what value to insert in the field.

The following model based on the Sudoku puzzle illustrates how to use the above functions.

```
! The sudoku puzzle in LINGO. Fill out a 9x9 grid with the digits
1,2,...9, so that each digit appears once in
  a) each column,
  b) each row,
  c) each of the nine 3x3 subsquares,
  d) the main diagonal,
  e) in the reflected diagonal;
! Some versions of the puzzle do not require (d) and (e)
! Keywords: sudoku, Puzzles;
SETS:
  SIDE;
  SS( SIDE, SIDE): X;
  SSS( SIDE,SIDE,SIDE): Y;
ENDSETS
DATA:
  SIDE = 1..9;
! Set diag = 1 if you want the diagonal constraints to be
  satisfied, else 0 if not required;
  diag = 0;
ENDDATA
! Variables:
  X(i,j) = value in row i, col j of matrix,
  Y(i,j,k) = 1 if X(i,j) = k;

! Any pre-specified entries inserted here;
  X(1,1) = 5;
  X(2,6) = 8;
  X(3,4) = 5;
  X(3,9) = 1;
  X(4,2) = 1;
  X(4,7) = 6;
  X(4,8) = 3;
```

```

X(9,1) = 9;
X(9,2) = 8;
X(9,5) = 6;

! Link X and Y;
@for( SS(i,j):
    X(i,j) = @sum(SIDE(k): k*y(i,j,k));
! Must choose something for cell i,j;
@sum(SIDE(k): y(i,j,k)) = 1;
! Make the Y's binary;
@for(SIDE(k): @bin(y(i,j,k)));
);

! Force each number k to appear once in each column j;
@for( SIDE(j):
    @for( SIDE(k):
        @sum( SIDE(i): Y(i,j,k)) = 1;
    ); );
! Force each number k to appear once in each row i;
@for( SIDE(i):
    @for( SIDE(k):
        @sum( SIDE(j): Y(i,j,k)) = 1;
    ); );
! Force each number k to appear once in each 3x3 subsquare;
@for( SIDE(k):
    ! Upper left;
    @sum( SS(i,j) | i #le#3 #and# j #le# 3: y(i,j,k)) = 1;
    ! Upper middle;
    @sum( SS(i,j) | i #le#3 #and# j #gt# 3 #and# j#le# 6: y(i,j,k)) = 1;
    ! Upper right;
    @sum( SS(i,j) | i #le#3 #and# j #gt# 6: y(i,j,k)) = 1;
    ! Middle left;
    @sum( SS(i,j) | i #gt#3 #and# i #le#6 #and# j #le# 3: y(i,j,k)) = 1;
    ! Middle middle;
    @sum( SS(i,j) | i #gt#3 #and# i #le#6 #and# j #gt# 3 #and# j #le# 6:
y(i,j,k)) = 1;
    ! Middle right;
    @sum( SS(i,j) | i #gt#3 #and# i #le#6 #and# j #gt# 6 #and# j #le# 9:
y(i,j,k)) = 1;
    ! Lower left;
    @sum( SS(i,j) | i #gt#6 #and# i #le#9 #and# j #gt# 0 #and# j #le# 3:
y(i,j,k)) = 1;
    ! Lower middle;
    @sum( SS(i,j) | i #gt#6 #and# i #le#9 #and# j #gt# 3 #and# j #le# 6:
y(i,j,k)) = 1;
    ! Lower right;
    @sum( SS(i,j) | i #gt#6 #and# i #le#9 #and# j #gt# 6 #and# j #le# 9:
y(i,j,k)) = 1;

    ! Force each number k to appear once in the main diagonal;
    @sum( SS(i,j) | i #eq# j: diag*y(i,j,k)) = diag;
    ! Force each number k to appear once in the reflected diagonal;
    @sum( SS(i,j) | i + j #eq# 10: diag*y(i,j,k)) = diag;

```

```

);

DATA:
! Write the solution in matrix form;
@TEXT() =
  @WRITE( @NEWLINE( 1), 25*' ', 'Sudoku Puzzle Solution',
    @NEWLINE( 1));
@TEXT() =
  @WRITEFOR( SIDE( i):
    @WRITEFOR( SIDE( j):
      @FORMAT( '#8.0g', x( i, j) )
    ) , @NEWLINE( 1)
  );
@TEXT() = ' ';
ENDDATA

```

19.5 Reducing Model Size

Practical LP models tend to be large. Thus, it makes sense to talk about the management of these models. Some of the important issues are:

1. Choosing an appropriate formulation. Frequently, there are two conflicting considerations: (a) the model should be large enough to capture all important details of reality, and (b) the model should be solvable in reasonable time.
2. What input data are needed? How is it collected?
3. How do we create an explicit model from the current data? This process has traditionally been called matrix generation.
4. How is the model solved? Is it solvable in reasonable time? In reality, some optimization program must be selected.

In this section, we discuss issues (1) and (3). The selection of an appropriate formulation also has implications for how easily a model is solved (issue 4).

We begin our discussion with how to choose a formulation that is small and thus more easily solved (usually).

The computational difficulty of an LP is closely related to three features of the LP: the number of rows, the number of columns, and the number of nonzeros in the constraint matrix. For linear programs, the computation time tends to increase with the square of the number of nonzeros. Thus, there is some motivation to (re)formulate LP models, so they are small in the above-mentioned three dimensions.

A number of commercial LP solvers have built-in commands, with names like REDUCE, that will mechanically do simple kinds of algebraic substitutions and eliminations necessary for reduction. Brearley, Mitra, and Williams (1975) give a thorough description of these reductions.

19.5.1 Reduction by Aggregation

We say we aggregate a set of variables if we replace a set of variables by a single variable. We aggregate a set of constraints if we replace a set of constraints by a single constraint. If we do aggregation, we must resolve several issues:

1. After solving the LP, there must be a postprocessing/disaggregation phase to deduce the disaggregate values from the aggregate values.
2. If row aggregation was performed, the solution to the aggregate problem may not be feasible to the true disaggregate problem.
3. If variable aggregation was performed, the solution to the aggregate problem may not be optimal to the true disaggregate problem.

To illustrate (2), consider the LP:

$$\begin{array}{ll} \text{Maximize} & 2x + y \\ \text{subject to} & x \leq 1 \\ & y \leq 1 \\ & x, y \geq 0 \end{array}$$

The optimal solution is $x = y = 1$; with objective value equal to 3. We could aggregate the rows to get:

$$\begin{array}{ll} \text{Maximize} & 2x + y \\ \text{subject to} & x + y \leq 2 \\ & x, y \geq 0 \end{array}$$

The optimal solution to this aggregate problem is $x = 2, y = 0$, with objective value equal to 4. However, this solution is not feasible to the original problem.

To illustrate (3), consider the LP:

$$\begin{array}{ll} \text{Minimize} & x_1 + x_2 \\ \text{subject to} & x_1 \geq 2 \\ & x_2 \geq 1 \\ & x_1, x_2 \geq 0 \end{array}$$

The optimal solution is $x_1 = 2, x_2 = 1$, with objective value equal to 3. We could aggregate variables to get the LP:

$$\begin{array}{ll} \text{Minimize} & 2x \\ \text{subject to} & x \geq 2 \\ & x \geq 1 \\ & x \geq 0 \end{array}$$

The optimal solution to the aggregate problem is $x = 2$, with objective value equal to 4. This solution is, however, not optimal for the original, disaggregate LP.

19.5.1.1 Example: The Room Scheduling Problem

We will illustrate both variable and constraint aggregation with a problem that confronts any large hotel that has extensive conference facilities for business meetings. The hotel has r conference rooms available of various sizes. Over the next t time periods (e.g., days), the hotel must schedule g groups of people into these rooms. Each group has a hard requirement for a room of at least a certain size. Each group may also have a preference of certain time periods over others. Each group requires a room for exactly one time period. The obvious formulation is:

$$V_{gtr} = \text{value of assigning group } g \text{ to time period } t \text{ in room } r. \text{ This value is provided by group } g, \text{ perhaps as a ranking. The decision variables are:}$$

$$X_{gtr} = 1 \text{ if group } g \text{ is assigned to room } r \text{ in time period } t. \text{ This variable is defined for each group } g, \text{ each time period } t, \text{ and each room } r \text{ that is big enough to accommodate group } g.$$

$$= 0 \text{ otherwise.}$$

The constraints are:

$$\sum_t \sum_r x_{gtr} = 1 \quad \text{for each group } g$$

$$\sum_g x_{gtr} \leq 1 \quad \text{for each room } r, \text{ time period } t$$

$$x_{gtr} = 0 \text{ or } 1 \quad \text{for all } g, t, \text{ and } r$$

The objective is:

$$\text{Maximize} \quad \sum_g \sum_t \sum_r V_{gtr} x_{gtr}$$

The number of constraints in this problem is $g + r \times t$. The number of variables is approximately $g \times t \times r/2$. The 1/2 is based on the assumption that, for a typical group, about half of the rooms will be big enough.

A typical problem instance might have $g = 250$, $t = 10$, and $r = 30$. Such a problem would have 550 constraints and about 37,500 variables. A problem of that size is nontrivial to solve, so we might wish to work with a smaller formulation.

Aggregation of variables can be used validly if a group is indifferent between rooms b and c , as long as both rooms b and c are large enough to accommodate the group. In terms of our notation, $V_{gtb} = V_{gtc}$ for every g and t if both rooms b and c are large enough for g . More generally, two variables can be aggregated if, in each row of the LP, they have the same coefficients. Two constraints in an LP can be validly aggregated if, in each variable, they have the same coefficients. We will do constraint aggregation by aggregating together all rooms of the same size. This aggregation process is representative of a fundamental modeling principle: when it comes to solving the model, *do not distinguish things that do not need distinguishing*.

The aggregate formulation can now be defined:

$$K = \text{number of distinct room sizes}$$

$$N_k = \text{number of rooms of size } k \text{ or larger}$$

$$S_k = \text{the set of groups, which require a room of size } k \text{ or larger}$$

$$V_{gt} = \text{value of assigning group } g \text{ to time period } t$$

$$x_{gt} = 1 \text{ if group } g \text{ is assigned to a room in time period } t$$

$$= 0 \text{ otherwise}$$

The constraints are:

$$\sum_i x_{gt} = 1 \quad \text{for each group } g$$

$$\sum_{g \in S_k} x_{gt} \leq N_k \quad \text{for each room size } k.$$

The objective is:

$$\text{Maximize } \sum_g \sum_t V_{gt} X_{gt}$$

This formulation will have $g + k \times t$ constraints and $g \times t$ decision variables. For the case $g = 250$, $t = 10$, and $r = 30$, we might have $k = 4$. Thus, the aggregate formulation would have 290 constraints and 2500 variables, compared with 550 constraints and 37,500 variables for the disaggregate formulation.

The post processing required to extract a disaggregate solution from an aggregate solution to our room scheduling problem is straightforward. For each time period, the groups assigned to that time period are ranked from largest to smallest. The largest group is assigned to the largest room, the second largest group to the second largest room, etc. Such an assignment will always be feasible as well as optimal to the original problem.

19.5.1.2 Example 2: Reducing Rows by Adding Additional Variables

If two parties, A and B , to a financial agreement, want the agreement to be treated as a lease for tax purposes, the payment schedule typically must satisfy certain conditions specified by the taxing agency. Suppose P_i is the payment A is scheduled to make to B in month i of a seven-year agreement. Parties A and B want to choose at the outset a set of P_j 's that satisfy a tax regulation that no payment in any given month can be less than $2/3$ of the payment in any earlier month. If there are T periods, the most obvious way of writing these constraints is:

$$\text{For } i = 2, T:$$

$$\text{For } j = 1, i - 1:$$

$$P_i \geq 0.66666 P_j$$

This would require $T(T - 1)/2$ constraints. A less obvious approach would be to define PM_i as the largest payment occurring any period before i . The requirement could be enforced with:

$$PM_1 = 0$$

$$\text{For } i = 2 \text{ to } T:$$

$$P_i \geq 0.66666 PM_i$$

$$PM_i \geq PM_{i-1}$$

$$PM_i \geq P_{i-1}$$

This would require $3T$ constraints rather than $T(T - 1)/2$. For $T = 84$, the difference is between 3486 constraints and 252.

19.5.2 Reducing the Number of Nonzeroes

If a certain linear expression is used more than once in a model, you may be able to reduce the number of nonzeroes by substituting it out. For example, consider the two-sided constraints frequently encountered in metal blending models:

$$L_i \leq \frac{\sum_j q_{ij} X_j}{\sum_j X_j} \leq U_i \quad (\text{for each quality characteristic } i).$$

In these situations, L_k and U_k are lower and upper limits on the i th quality requirement, and q_{ij} is the quality of ingredient j with respect to the i th quality. The “obvious” way of writing this constraint in linear form is:

$$\begin{aligned} \sum_j (q_{ij} - L_i) X_j &\geq 0, \\ \sum_j (q_{ij} - U_i) X_j &\leq 0. \end{aligned}$$

By introducing a batch size variable B and a slack variable s_i , this can be rewritten:

$$\begin{aligned} B - \sum_j X_j &= 0 \\ \sum_j q_{ij} X_j + s_i &= U_i \times B \\ s_i &\leq (U_i - L_i) \times B \end{aligned}$$

If there are m qualities and n ingredients, the original formulation had $2 \times m \times n$ nonzeroes. The modified formulation has $n + 1 + m \times (n + 2) + m \times 2 = n + 1 + m \times (n + 4)$ nonzeroes. For large n , the modified formulation has approximately 50% fewer nonzeroes.

19.5.3 Reducing the Number of Nonzeroes in Covering Problems

A common feature in some covering and multiperiod financial planning models is each column will have the same coefficient (e.g., + 1) in a large number of rows. A simple transformation may substantially reduce the number of nonzeroes in the model. Suppose row i is written:

$$\sum_{j=1}^n a_{ij} X_j = a_{i0}$$

Now, suppose we subtract row $i - 1$ from row i , so row i becomes:

$$\sum_{j=1}^n (a_{ij} - a_{i-1,j}) X_j = a_{i0} - a_{i-1,0}$$

If $a_{ij} = a_{i-1,j} \neq 0$ for most j , then the number of nonzeroes in row i is substantially reduced.

Figure 19.3
Nonzero Pattern for X Variables in Transformed Formulation
X Variables

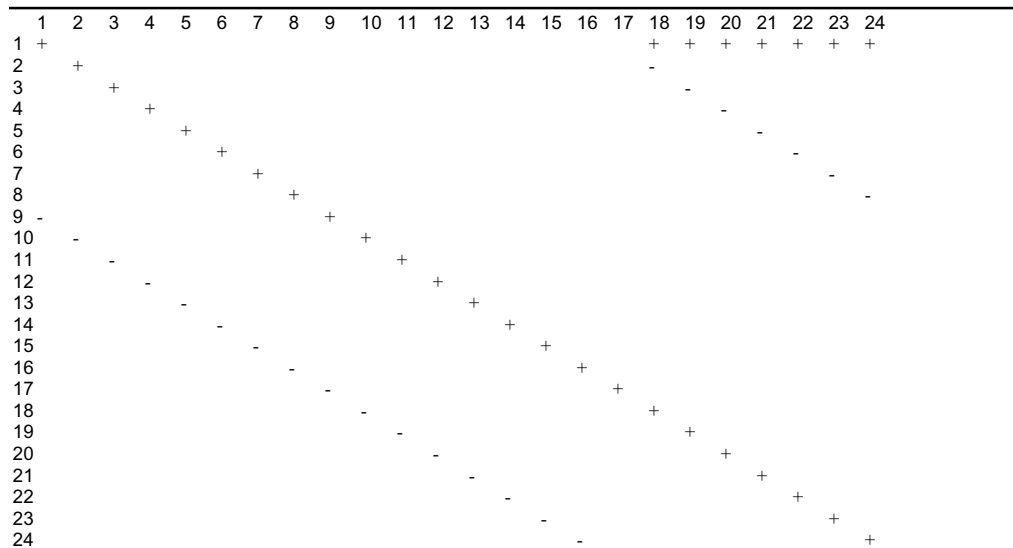

19.6 On-the-Fly Column Generation

There are a number of generic LP models that have a modest number of rows (e.g., a hundred or so), but a large number of columns (e.g., a million or so). This is frequently the case in cutting stock problems. This could also be the case in staffing problems, where there might be many thousands of different work patterns people could work. Explicitly generating all these columns is not a task taken lightly. An alternative approach is motivated by the observation that, at an optimum, there will be no more positive columns than there are rows.

The following iterative process describes the basic idea:

1. Generate and solve an initial LP that has all the rows of the full model defined, but only a small number (perhaps even zero) of the columns explicitly specified.
2. Given the dual prices of the current solution, generate one or more columns that price out attractively. That is, if a_{0j} is the cost of column j , a_{ij} is its usage of resource i (i.e., its coefficient in rows i for $i = 1, \dots, m$), and p_i is the dual price of row i , then generate or find a new column a such that:

$$a_{0j} + p_1 a_{1j} + p_2 a_{2j} + \dots + p_m a_{mj} < 0.$$
 If no such column exists, then stop.
3. Solve the LP with the new column(s) from (2) added.
4. Go to (2).

The crucial step is (2). To use column generation for a specific problem, you must be able to solve the column generation subproblem in (2). In mathematical programming form, the subproblem in (2) is:

Given $\{p_j\}$, solve

$$\text{Min } a_{0j} + p_1 a_{1j} + p_2 a_{2j} + \dots + p_m a_{mj}$$

subject to:

The a_{ij} satisfy the conditions defining a valid column.

19.6.1 Example of Column Generation Applied to a Cutting Stock Problem

A common problem encountered in flat goods industries, such as paper, textiles, and steel, is the cutting of large pieces of raw material into smaller pieces needed for producing a finished product. Suppose raw material comes in 72" widths and it must be cut up into eight different finished good widths described by the following table:

Product	Width in Inches	Linear feet Required
1	60	500
2	56	400
3	42	300
4	38	450
5	34	350
6	24	100
7	15	800
8	10	1000

We start the process somewhat arbitrarily by defining the eight pure cutting patterns. A pure pattern produces only one type of finished good width. Let P_i = number of feet of raw material to cut according to the pattern i . We want to minimize the total number of feet cut. The LP with these patterns is:

```

MIN =P001 + P002 + P003 + P004 + P005 + P006 + P007 + P008;
[W60]    P001 >= 500; !      (60 inch width);
[W56]    P002 >= 400; !      (56 inch width);
[W42]    P003 >= 300; !      (42 inch width);
[W38]    P004 >= 450; !      (38 inch width);
[W34] 2 * P005 >= 350; !      (34 inch width);
[W24] 3 * P006 >= 100; !      (24 inch width);
[W15] 4 * P007 >= 800; !      (15 inch width);
[W10] 7 * P008 >= 1000; !     (10 inch width);
END

```

The solution is:

Optimal solution found at step:		0
Objective value:		2201.190
Variable	Value	Reduced Cost
P001	500.0000	0.0000000
P002	400.0000	0.0000000
P003	300.0000	0.0000000
P004	450.0000	0.0000000
P005	175.0000	0.0000000
P006	33.33333	0.0000000
P007	200.0000	0.0000000
P008	142.8571	0.0000000
Row	Slack or Surplus	Dual Price
1	2201.190	1.0000000
W60	0.0000000	-1.0000000
W56	0.0000000	-1.0000000
W42	0.0000000	-1.0000000
W38	0.0000000	-1.0000000
W34	0.0000000	-0.5000000
W24	0.0000000	-0.3333333
W15	0.0000000	-0.2500000
W10	0.0000000	-0.1428571

The dual prices provide information about which finished goods are currently expensive to produce. A new pattern to add to the problem can be found by solving the problem:

$$\text{Minimize } 1 - y_1 - y_2 - y_3 - y_4 - 0.5y_5 - 0.333333y_6 - 0.25y_7 - 0.142857y_8$$

subject to

$$60y_1 + 56y_2 + 42y_3 + 38y_4 + 34y_5 + 24y_6 + 15y_7 + 10y_8 \leq 72$$

$$y_i = 0, 1, 2, \dots \quad \text{for } i = 1, \dots, 8.$$

Note the objective can be rewritten as:

$$\text{Maximize } y_1 + y_2 + y_3 + y_4 + 0.5y_5 + 0.333333y_6 + 0.25y_7 + 0.142857y_8$$

This is a knapsack problem. Although knapsack problems are theoretically difficult to solve, there are algorithms that are quite efficient on typical practical knapsack problems. An optimal solution to this knapsack problem is $y_4 = 1, y_7 = 2$ (i.e., a pattern that cuts one 38" width and two 15" widths). When this column, P009, is added to the LP, we get the formulation (in Picture form):

	P	P	P	P	P	P	P	P	P	
	0	0	0	0	0	0	0	0	0	
	0	0	0	0	0	0	0	0	0	
	1	2	3	4	5	6	7	8	9	
1:	1	1	1	1	1	1	1	1	1	MIN
2:	1									> C
3:	'	1	'		'		'		'	> C
4:			1	'			'			> C
5:				1			'		1	> C
6:	'		'	2	'		'			> C
7:					'	3	'			> B
8:					'		4		2	> C
9:	'		'		'		'	7	'	> C

The solution is:

Optimal solution found at step:	3	
Objective value:	2001.190	
Variable	Value	Reduced Cost
P001	500.0000	0.0000000
P002	400.0000	0.0000000
P003	300.0000	0.0000000
P004	50.00000	0.0000000
P005	175.0000	0.0000000
P006	33.33333	0.0000000
P007	0.0000000	1.0000000
P008	142.8571	0.0000000
P009	400.0000	0.0000000
Row	Slack or Surplus	Dual Price
1	2001.190	1.0000000
W60	0.0000000	-1.0000000
W56	0.0000000	-1.0000000
W42	0.0000000	-1.0000000
W38	0.0000000	-1.0000000
W34	0.0000000	-0.5000000
W24	0.0000000	-0.3333333
W15	0.0000000	0.0000000
W10	0.0000000	-0.1428571

The column generation subproblem is:

$$\begin{aligned} &\text{Minimize } y_1 + y_2 + y_3 + y_4 + 5y_5 + 0.333333y_6 + 0.142857y_8 \\ &\text{subject to} \\ &60y_1 + 56y_2 + 42y_3 + 38y_4 + 34y_5 + 24y_6 + 15y_7 + 10y_8 \leq 72 \\ &y_i = 0, 1, 2, \dots \quad \text{for } i = 1, \dots, 8. \end{aligned}$$

An optimal solution to this knapsack problem is $y_4 = 1, y_5 = 1$ (i.e., a pattern that cuts one 38" width and one 34" width).

We continue generating and adding patterns for a total of eight iterations. At this point, the LP formulation is:

```

P P P P P P P P P P P P P P
0 0 0 0 0 0 0 0 0 0 0 0 0 0
0 0 0 0 0 0 0 0 0 1 1 1 1 1
1 2 3 4 5 6 7 8 9 0 1 2 3 4 5
1: 1 1 1 1 1 1 1 1 1 1 1 1 1 1 MIN
2: 1 ' ' ' ' ' ' ' ' ' ' 1 > C
3: ' 1' ' ' ' ' ' ' ' ' ' ' > C
4: ' 1' ' ' ' ' ' ' 1' ' 1' > C
5: ' ' 1' ' ' ' 1 1' 1' > C
6: ' ' ' 2' ' ' ' 1' ' ' ' > C
7: ' ' ' 3' ' ' ' ' 1' > B
8: ' ' ' 4' 2' 2 1' ' > C
9: ' ' ' ' ' 7' ' ' ' 1 3'1 > C
    
```

The solution is:

```

Optimal solution found at step:      10
Objective value:                    1664.286
Variable      Value      Reduced Cost
P001          0.0000000    0.1428571
P002          0.0000000    0.2142857
P003          0.0000000    0.4285714
P004          0.0000000    0.4285714
P005          0.0000000    0.1428571
P006          0.0000000    0.1428571
P007          0.0000000    0.1428571
P008          14.28571     0.0000000
P009          0.0000000    0.0000000
P010          350.0000     0.0000000
P011          200.0000     0.0000000
P012          400.0000     0.0000000
P013          100.0000     0.0000000
P014          100.0000     0.0000000
P015          500.0000     0.0000000
Row      Slack or Surplus      Dual Price
1         1664.286             1.000000
W60        0.0000000           -0.8571429
W56        0.0000000           -0.7857143
W42        0.0000000           -0.5714286
W38        0.0000000           -0.5714286
W34        0.0000000           -0.4285714
W24        0.0000000           -0.2857143
W15        0.0000000           -0.2142857
W10        0.0000000           -0.1428571
    
```

The relevant knapsack problem is:

$$\begin{aligned} &\text{Maximize} \\ &0.857143y_1 + 0.785714y_2 + 0.571429y_3 + 0.523809y_4 \\ &\quad + 0.476191y_5 + 0.333333y_6 + 0.214285y_7 + 0.142857y_8 \\ &\text{subject to} \\ &60y_1 + 56y_2 + 42y_3 + 38y_4 + 34y_5 + 24y_6 + 15y_7 + 10y_8 \leq 72 \\ &y_i = 0, 1, 2, \dots \quad \text{for } i = 1, \dots, 8. \end{aligned}$$

The optimal solution to the knapsack problem has an objective function value less-than-or-equal-to one. Because each column, when added to the LP, has a “cost” of one in the LP objective, when the proposed column is priced out with the current dual prices, it is unattractive to enter. Thus, the previous LP solution specifies the optimal amount to run of all possible patterns. There are in fact 29 different efficient patterns possible, where efficient means the edge waste is less than 10". Thus, the column generation approach allowed us to avoid generating the majority of the patterns.

If an integer solution is required, then a simple rounding up heuristic tends to work moderately well. In our example, we know the optimal integer solution costs at least 1665. By rounding P008 up to 15, we obtain a solution with cost 1665.

19.6.2 Column Generation and Integer Programming

Column generation can be used to easily find an optimum solution to an LP. This is not quite true with IP's. The problem is, with an IP, there is no simple equivalent to dual price. Dual prices may be printed in an IP solution, but they have an extremely limited interpretation. For example, it may be that all dual prices are 0 in an IP solution.

Thus, the usual approach, when column generation is used to attack IP's, is to use column generation only to solve the LP relaxation. A standard IP algorithm is then applied to the problem composed of only the columns generated during the LP. However, it may be that a true IP optimum includes one or more columns that were not generated during the LP phase. The LP solution, nevertheless, provides a bound on the optimum LP solution. In our previous cutting stock example, this bound was tight.

There is a fine point to be made with regard to the stopping rule. We stop, *not* when the previous column added leads to no improvement in the LP solution, but when the latest column generated prices out unattractively.

19.6.3 Row Generation

An analogous approach can be used if the problem intrinsically has many thousands of constraints even though only a few of them will be binding. The basic approach is:

1. Generate some of the constraints.
2. Solve the problem with the existing constraints.
3. Find a constraint that has not been generated, but is violated. If none, we are done.
4. Add the violated constraint and go to (2)

5. A common footnote seen in financial reports is a phrase like: “numbers may not sum to 100 because of rounding”. This is an example the rounding problem frequently encountered when preparing reports. In its simplest form, one is given a column of numbers, some of which have fractional parts. One wants to round the numbers to integers, or to numbers with fewer fractional digits, so that the sum of the rounded numbers equals the sum of the original numbers. Some variations of this problem are: a) in regulated utilities where a firm is allowed to round certain charges to a multiple of a nickel, subject to having the total equal a certain quantity; b) in some parliaments, e.g., the U.S. House of Representatives, each state is supposed to have an integer number of representatives(out of a fixed total of 435) proportional to the state’s population. To illustrate, consider the following two sets of numbers and their sums:

<u>Set 1</u>	<u>Set 2</u>
23.3	3.7
15.4	11.6
<u>61.3</u>	9.8
100.0	47.7
	9.6
	11.5
	<u>6.1</u>
	100.0

Notice that for both examples, if you round each component to the nearer integer, the results will not sum to 100.

a) Specify a method for rounding the components of an arbitrary set of numbers, extolling the virtues of your method.

b) Illustrate your method on the two examples.

6. You have created a supply chain modeling system that can accommodate from 1 to 10 products, from 1 to 6 suppliers, from 1 to 25 customers, and from 1 to 12 time periods. In order to test your modeling system you want run at least one case for each extreme of each dimension. In case there is a bug in your modeling system that depends upon interactions between two dimension you also want to run at least one case for each pair of extremes. For example, considering products and suppliers, you want to run at least four cases covering: 1) 1 product and 1 supplier, 2) 1 product and 6 suppliers, 3) 10 products and 1 supplier, 4) 10 products and 6 suppliers. Note that a given test case in fact covers one product setting, one supplier setting, one customer setting, and one number-of-periods setting. What is the minimum number of test cases you need to run, so that if you consider any pair of dimensions, each of the four combinations of extreme cases have been run?

References

- Adams, J.L. (1986), *Conceptual Blockbusting*, Addison-Wesley, Reading, MA.
- Ahuja, R. K., T. L. Magnanti, J. B. Orlin (1993), *Network Flows, Theory, Algorithms, and Applications*, Prentice-Hall, Englewood Cliffs, NJ.
- Andrews, B. and H. Parsons(1993), "Establishing Telephone-Agent Staffing Levels through Economic Optimization", *Interfaces*, Vol. 23, No. 2, pp. 14-20.
- Arnold, L., and D. Botkin. "Portfolios to Satisfy Damage Judgement: A Linear Programming Approach", *Interfaces*, Vol. 8, No. 2 (Feb. 1978).
- Aykin, T. (1996), "Optimal Shift Scheduling with Multiple Break Windows", *Management Science*, Vol. 42 No. 4 (April), pp. 591-602.
- Baker, E. K. and M. L. Fisher (1981), "Computational Results for Very Large Air Crew Scheduling Problems", *Omega*, Vol. 9, pp. 613-618.
- Balas, E. (1979), "Disjunctive Programming", *Annals of Discrete Mathematics*, Vol. 5, pp. 3-51.
- Banks, J. and R. Gibson (1997), "10 Rules for Determining When Simulation is Not Appropriate", *IIE Solutions*, Vol. 29, No. 9 (September), pp. 30-32.
- Barnett, A. (1994), "How Numbers Can Trick You", *Technology Review*, MIT, Vol. 97, No. 7(October), pp. 38-45.
- Belobaba, P.P.(1989),"Application of a Probabilistic Decision Model to Airline Seat Inventory Control", *Operations Research*, vol. 37, no. 2, (March-April) pp. 183-197.
- Bessent, A., W. Bessent, J. Kennington, and B. Reagan (1982), "An Application of Mathematical Programming to Assess Productivity in the Houston Independent School District", *Management Science*, Vol. 28, No. 12 (December), pp. 1355-1367.
- Birge, J. R. (1997), "Stochastic Programming Computation and Applications", *INFORMS Journal on Computing*, Vol. 9, No. 2, pp.111-133.
- Birge, J. and F. Louveaux (1997), *Introduction to Stochastic Programming*, Springer-Verlag, New York, NY.
- Black, F. (1989), "How We Came Up with the Option Formula", *The Journal of Portfolio Management*, Winter, pp. 4-8.
- Black, F., E. Derman, and W. Toy (1990), "A One-Factor Model of Interest Rates and Its Application to Treasury Bond Options", *Financial Analyst Journal*, Vol. 46, pp. 33-39.
- Black, F., and M. Scholes (1973), "The Pricing of Options and Corporate Liabilities", *Journal of Political Economy*, Vol. 81, pp. 637-654.
- Bland, R. G. and D. F. Shallcross (1989), "Large Traveling Salesman Problems Arising in X-ray Crystallography: A Preliminary Report on Computation", *O.R. Letters*, Vol. 8, No. 3, pp. 125-128.
- Bosch, R.A.(1993), "Big Mac Attack, The Diet Problem revisited: Eating at McDonald's", *OR/MS Today*, (August), pp. 30-31.

- Bracken, J. and G.P. McCormick (1968), *Selected Applications of Nonlinear Programming*, John Wiley & Sons, Inc., New York, NY.
- Bradley, G. H., G. G. Brown and G. W. Graves (1977), "Design and Implementation of Large Scale Primal Transshipment Algorithms", *Management Science*, Vol. 24, pp. 1-34.
- Bradley, S.P., A. C. Hax and T. L. Magnanti (1977), *Applied Mathematical Programming*, Addison-Wesley Publishing Company, Reading, Mass..
- Braess, D. (1968), "Uber ein Paradoxon aus der Verkehrplanung", *Unternehmensforschung*, Vol. 12, pp. 258-268.
- Brearley, A. L., G. Mitra and H. P. Williams (1975), "An Analysis of Mathematical Programming Problems Prior to Applying the Simplex Algorithm", *Mathematical Programming*, Vol. 8, pp. 54-83.
- Brown, G.G., R.F. Dell, and R.K. Wood (1997), "Optimization and Persistence", *Interfaces*, Vol. 27, No. 5, (Sept-Oct), pp. 15-37.
- Brown, G.G., C.J. Ellis, G.W. Graves, and D. Ronen (1987), "Real-Time, Wide Areas Dispatch of Mobil Tank Trucks", *Interfaces*, Vol. 17, No. 1, pp. 107-120.
- Brown, G. G. and D. S. Thomen (1980), "Automatic Identification of Generalized Upper Bounds in Large-Scale Optimization Models", *Management Science*, Vol. 26, No. 11, pp. 1166-1184.
- Carino, D.R., T. Kent, D.H. Myers, C. Stacy, M. Sylvanus, A.L. Turner, K. Watanabe, and W.T. Ziemba (1994), "The Russell-Yasuda Kasai Model: An Asset/Liability Model for a Japanese Insurance Company Using Multistage Stochastic Programming", *Interfaces*, Vol. 24, No. 1, pp. 29-49.
- Charnes, A., W.W. Cooper and E. Rhodes (1978), "Measuring the Efficiency of Decision Making Units", *European Journal of Operational Research*, Vol. 2 (1978) pp. 429-444.
- Ciriani, T.A. and R. C. Leachman (1993), *Optimization in Industry*, John Wiley & Sons, Chichester.
- Clarke, G. and J. W. Wright (1964), "Scheduling of Vehicles from a Central Depot to a Number of Delivery Points", *Operations Research*, Vol. 12, No. 4 (July-Aug.), pp. 568-581.
- Claus, A.(1984), "A New Formulation for the Travelling Salesman Problem", *SIAM Journal on Algebraic and Discrete Methods*, vol. 5, no. 1, pp. 21-25.
- Clyman, D.R. (1995), "Unreasonable Rationality?", *Management Science*, Vol 41, No. 9 (Sept.), pp. 1538-1548.
- Craven, J. P.(2001), *The Silent War: the Cold War Battle Beneath the Sea*, Simon & Schuster, New York.
- Dantzig, G. (1963), *Linear Programming and Extensions*, Princeton University Press, Princeton.
- Dantzig, G. B., D. R. Fulkerson, and S. M. Johnson(1954), "Solution of a Large-Scale Traveling-Salesman Problem", *Operations Research*, vol. 2, no. 4, pp. 393-410.
- Dantzig, G. and N. N. Thapa (1997), *Linear Programming*, Vol. 1, Springer, New York.
- Dantzig, G. and B. Wolfe (1960), "Decomposition Principle for Linear Programs", *Operations Research*, Vol. 8, pp. 101-111.

- Danusaputro, S., C. Lee, and L. Martin-Vega (1990), "An Efficient Algorithm for Drilling Printed Circuit Boards", *Computers and Industrial Engineering*, Vol. 18, pp. 145-151.
- Dauch, R.E. (1993), *Passion for Manufacturing*, Society of Manufacturing Engineers, Dearborn, MI.
- Davis, L. S. and K. N. Johnson (1987), *Forest Management*, 3rd ed., McGraw-Hill Company.
- Dembo, R.S., A. Chiarri, J.G. Martin, and L. Paradinas (1990), "Managing Hidroeléctrica Española's Hydroelectric Power System", *Interfaces*, Vol. 20, No. 1 (Jan.-Feb.), pp. 115-135.
- d'Epenoux, F. (1963), "A Probabilistic Production and Inventory Problem", *Management Science*, Vol. 10, No. 1 (Oct), pp. 98-108.
- DeRosa, D. (1992), *Options on Foreign Exchange*, Irwin Professional Publishing, New York.
- DeWitt, C. W., L. Lasdon, A. Waren, D. Brenner and S. Melhem (1989), "OMEGA: An Improved Gasoline Blending System for Texaco," *Interfaces*, Vol. 19, No. 1 (Jan.-Feb.), pp. 85-101.
- Dikin, I. I. (1967), "Iterative Solution of Problems of Linear and Quadratic Programming", *Soviet Mathematics Doklady*, Vol. 8, pp. 674-675.
- Dial, R.B. (1994), "Minimizing Trailer-on-Flat-Car Costs: A Network Optimization Model", *Transportation Science*, Vol. 28, pp. 24-35.
- Dutton, R., G. Hinman and C. B. Millham (1974), "The Optimal Location of Nuclear-Power Facilities in the Pacific Northwest", *Operations Research*, Vol. 22, No. 3 (May-June), pp. 478-487.
- Dyckhoff, H. (1981), "A New Linear Programming Approach to the Cutting Stock Problem", *Operations Research*, Vol. 29, No. 6 (Nov.-Dec.), pp. 1092-1104.
- Eddie, L. C. (1954), "Traffic Delays at Toll Booths", *Operations Research*, Vol. 2, No. 2 (May), pp. 107-138.
- Elshafei, A. (1977), "Hospital Lay-out as a Quadratic Assignment Problem", *Operational Research Quarterly*, Vol. 28, pp. 167-169.
- Emmelhainz, L. W., M. A. Emmelhainz, and J. R. Stock (1991), "Logistics Implications of Retail Stockouts", *Journal of Business Logistics*, Vol. 12, No. 2, pp. 129-142.
- Eppen, G., K. Martin, and L. Schrage (1988), "A Scenario Approach to Capacity Planning", *Operations Research*, Vol. 37, No. 4 (July-August), pp. 517-530.
- Eppen, G. D. and R. K. Martin (1987), "Solving Multi-Item Capacitated Lot-Sizing Problems Using Variable Redefinition." *Operations Research*, Vol. 35, No. 6 (Nov.-Dec.), pp. 832-848.
- Farley, A. A. (1990), "A Note on Bounding a Class of Linear Programming Problems, Including Cutting Stock Problems", *Operations Research*, Vol. 38, No. 5 (Sept.-Oct.), pp. 922-923.
- Fields, C., J. F. Hourican and E. A. McGee (1978), "Developing a Minimum Cost Feed Blending System for Intensive Use", *Joint National TIMS/ORSA Meeting*, New York, NY.
- Fieldhouse, M. (1993), "The Pooling Problem", *Optimization in Industry*, (Eds.) T. A. Ciriani and R. C. Leachman, John Wiley & Sons.
- Fillon, M. (1996), "Taming the Yangtze", *Popular Mechanics*, Vol. 173, No. 7 (July), pp. 52-56.

- Fisher, M. and A. Raman (1996), "Reducing the Cost of Demand Uncertainty Through Accurate Response to Early Sales", *Operations Research*, Vol. 44, No. 1 (Jan.-Feb.), pp. 87-99.
- Florian, M (1977), "An Improved Linear Approximation Algorithm for the Network Equilibrium (Packet Switching) Problem", *Proceedings 1977 IEEE Conference Decision and Control*.
- Fudenberg, D. and J. Tirole (1993) *Game Theory*, The MIT Press, Cambridge, MA.
- Gaballa, A. and W. Pearce(1979), "Telephone Sales Manpower Planning at Qantas", *Interfaces*, Vol. 9, No. 3,(May), pp. 1-9.
- Geoffrion, A. (1976), "The Purpose of Mathematical Programming is Insight, Not Numbers", *Interfaces*, Vol. 7, No. 1 (November), pp. 81-92.
- Geoffrion, A. and G. W. Graves (1974), "Multicommodity Distribution System Design by Benders Decomposition", *Management Science*, Vol. 20, No. 5 (January), pp. 822-844.
- Glover, F. and D. Klingman (1977), "Network Applications in Industry and Government", *AIIE Transactions*, Vol. 9, pp. 363-376.
- Golabi, K., R.B. Kulkarni, and G.B. Way (1982), "A Statewide Pavement Management System", *Interfaces*, Vol. 12, No. 6 (Nov.-Dec.), pp. 5-21.
- Gomory, R. E. (1958), "Outline of an Algorithm for Integer Solutions to Linear Programs", *Bulletin of the American Mathematical Society*, Vol. 64, pp. 275-278.
- Grandine, T.A.(1998), "Assigning Season Tickets Fairly", *Interfaces*, Vol. 28, No. 4(July-August), pp. 15-20.
- Graves, R., J. Sankaran, and L. Schrage (1993), "An Auction Method for Course Registration", *Interfaces*, Vol. 23, No. 5 (1993), pp. 81-92.
- Greenberg, H.J.(1978), *Design and Implementation of Optimization Software*, Sijthoff & Noordhoff.
- Grinold, R.C. (1983), "Model Building Techniques for the Correction of End Effects in Multistage Convex Programs", *Operations Research*, Vol. 31, No. 3, pp. 407-431.
- Gross, D. and C. Harris(1998), *Fundamentals of Queueing Theory*, 3rd ed., Wiley Interscience, New York.
- Grötschel, M., M. Jünger and G. Reinelt (1985), "Facets of the Linear Ordering Polytope", *Mathematical Programming*, Vol. 33, pp. 43-60.
- Gunawardane, G., S. Hoff and L. Schrage (1981), "Identification of Special Structure Constraints in Linear Programs", *Mathematical Programming*, Vol. 21, pp. 90-97.
- Hadley, G. (1962), *Linear Programming*, Addison-Wesley.
- Hane, C.A., C. Barnhart, E.L. Johnson, R.E. Marsten, G.L. Nemhauser, G. Sigismondi (1995), "The Fleet Assignment Problem: Solving a Large Scale Integer Program", *Mathematical Programming*, Vol. 70, pp. 211-232.
- Hansen, C.T., K. Madsen, and H.B. Nielsen (1991), "Optimization of Pipe Networks", *Mathematical Programming*, Vol. 52, pp. 45-58.

- Hanson, W. and R. K. Martin (1990), "Optimal Bundle Pricing", *Management Science*, Vol. 36, No. 2 (February), pp. 155-174.
- Haverly, C. A. (1978), "Studies of the Behavior of Recursion for the Pooling Problem", *SIGMAP Bulletin*, Association for Computing Machinery.
- Heath, D., R. Jarrow, and A. Morton (1992), "Bond Pricing and the Term Structure of Interest Rates: A New Methodology for Contingent Claims Valuation", *Econometrica*, Vol. 60, No. 1, pp. 77-105.
- Held, M. and R. Karp (1962), "A Dynamic Programming Approach to Sequencing Problems", *SIAM Journal of Applied Math*, vol. 10, no. 1, pp. 196-210.
- Infanger, G. (1994), *Planning Under Uncertainty: Solving Large-Scale Stochastic Linear Programs*, Boyd & Fraser, Danvers, MA.
- Jackson, J.R. (1963), "Jobshop-Like Queueing Systems", *Management Science*, Vol. 10, No. 1, pp. 131-142.
- Jenkins, L. (1982), "Parametric Mixed Integer Programming: An Application to Solid Waste Management", *Management Science*, Vol 28, No. 11 (Nov.), pp. 1270-1284.
- Jeroslow, R.G., K. Martin, R.L. Rardin, J. Wang (1992), "Gainfree Leontief Substitution Flow Problems", *Mathematical Programming*, Vol. 57, pp. 375-414.
- Jorion, P. (2001), *Value at Risk*, 2nd ed., McGraw-Hill.
- Kall, P. and S.W. Wallace (1994), *Stochastic Programming*, John Wiley & Sons, New York, NY.
- Karmarkar, N. K. (1985), "A New Polynomial Time Algorithm for Linear Programming", *Combinatorica*, Vol. 4, pp. 373-395.
- Kehoe, T.J. (1985), "A Numerical Investigation of Multiplicity of Equilibria", *Mathematical Programming Study* 23, pp. 240-258.
- Khachian, L. G. (1979), "A Polynomial Algorithm in Linear Programming", *Soviet Mathematics Doklady*, Vol. 20, No. 1, pp. 191-194.
- King, R. H. and Love, R. R. (1980), "Coordinating Decisions for Increased Profits", *Interfaces*, Vol. 10, No. 6 (December), pp. 4-19.
- Konno, H. and H. Yamazaki (1991), "Mean-Absolute Deviation Portfolio Optimization Model and Its Applications to Tokyo Stock Market", *Management Science*, Vol. 37, No. 5 (May), pp. 519-531.
- Kontogiorgis, S. and S. Acharya (1999), "US Airways Automates Its Weekend Fleet Assignment", *Interfaces*, Vol. 29, No. 3 (May-June), pp. 52-62).
- Koopmans, T. and M. Beckmann (1957), "Assignment Problems and the Location of Economic Activities", *Econometrica*, Vol. 25, pp. 53-76.
- Kruskal, Jr., J. B. (1956), "On the Shortest Spanning Subtree of a Graph and the Traveling Salesman Problem", *Proc. Amer. Math. Soc.*, Vol. 7, pp. 48-50.
- Lasdon, L. S., and Terjung, R. C. (1971), "An Efficient Algorithm for Multi-Item Scheduling", *Operations Research*, Vol. 19, No. 4, pp. 946-69.

- Lawler, E. L. (1963), "The Quadratic Assignment Problem", *Management Science*, Vol. 19, pp. 586-599.
- Lawler, E. L., J. K. Lenstra, A. H. G. Rinnooy Kan and D. B. Shmoys (1985), "The Traveling Salesman Problem: A Guided Tour of Combinatorial Optimization", John Wiley & Sons.
- Leontief, W. (1951), *The Structure of American Economy, 1919-1931*, Oxford University Press, New York, NY.
- Levy, F. K. (1978), "Portfolios to Satisfy Damage Judgements: A Simple Approach", *Interfaces*, Vol. 9, No. 1 (Nov.), pp. 106-107.
- Lin, S. and B. Kernighan (1973), "An Effective Heuristic Algorithm for the Traveling Salesman Problem", *Operations Research*, Vol. 21, pp. 498-516.
- Little, J. D. C. (1961), "A Proof of the Queuing Formula $L = \lambda W$ ", *Operations Research*, Vol. 9, No. 3 (May-June), pp. 383-387.
- Madansky, A. (1962), "Methods of Solution of Linear Programs Under Uncertainty", *Operations Research*, Vol. 10, pp. 463-471.
- Mangasarian, O.L. (1993), "Mathematical Programming in Neural Networks", *ORSA Journal on Computing*, Vol. 5, No. 4, pp. 349-360.
- Manne, A. (1960), "Linear Programming and Sequential Decisions", *Management Science*, Vol. 6, No. 3 (April), pp. 259-267.
- Markowitz, H. M. (1959), *Portfolio Selection, Efficient Diversification of Investments*, John Wiley & Sons, Inc..
- Markowitz, H. and A. Perold (1981), "Portfolio Analysis with Scenarios and Factors", *Journal of Finance*, Vol. 36, pp. 871-877.
- Marsten, R. E., M. P. Muller and C. L. Killion (1979), "Crew Planning at Flying Tiger: A Successful Application of Integer Programming", *Management Science*, Vol. 25, No. 12 (Dec.), pp. 1175-1183.
- Marsten, R. E., M. J. Saltzman, D. F. Shanno, G. S. Pierce, and J. F. Ballintijn (1989), "Implementation of a Dual Affine Interior Point Algorithm for Linear Programming", *ORSA J. on Computing*, Vol. 1, No. 4, pp. 287-297.
- Martin, R. K. (1999) *Large Scale Linear and Integer Optimization: A Unified Approach*, Kluwer Academic Publishers, Boston.
- Maschler, M., B. Peleg, and L. S. Shapley (1979), "Geometric Properties of the Kernel, Nucleolus, and Related Solution Concepts", *Mathematics of Operations Research*, Vol. 4, No. 4 (Nov.), pp. 303-338.
- Mehrabian, S. G. Jahanshahloo, M. Alirezaee, and G. Amin (2000) "An Assurance Interval for the non_Archimedean Epsilon in DEA Models", *Operations Research*, Vol. 48, No. 2, pp. 344-347.
- Miller, H. E., W. P. Pierskalla and G. J. Rath (1976), "Nurse Scheduling using Mathematical Programming", *Operations Research*, Vol. 24, pp. 857-870.
- Miller, C. E., A. W. Tucker, and R. A. Zemlin (1960), "Integer Programming Formulations and Traveling Salesman Problems", *Journal of ACM*, pp. 326-329.

- Moldovanu, B. and M. Tietzel (1998) "Goethe's Second-Price Auction", *Journal of Political Economy*, Vol. 106, No. 4, pp. 854-858
- Murchland, J. D. (1970), "Braess's Paradox of Traffic Flow", *Transportation Research*, Vol. 4, pp. 391-394.
- Nahmias, S.(1997) *Production and Operations Analysis*, 3rd ed., Irwin Publishing, Homewood, IL.
- Nauss, R. M. (1986), "True Interest Cost in Municipal Bond Bidding: An Integer Programming Approach", *Management Science*, Vol. 32, No. 7, pp. 870-877.
- Nauss, R. M. and B. R. Keeler (1981), "Minimizing Net Interest Cost in Municipal Bond Bidding", *Management Science*, Vol. 27, No. 4 (April), pp. 365-376.
- Nauss, R. M. And R. Markland (1981), "Theory and Application of an Optimization Procedure for Lock Box Location Analysis", *Management Science*, Vol. 27, No. 8 (August), pp. 855-865.
- Neebe, A. W. (1987), "An Improved, Multiplier Adjustment Procedure for the Segregated Storage Problem", *Journal of the Operational Research Society*, Vol. 38, No. 9, pp. 1-11.
- Orlin, J.B. (1982), "Minimizing the Number of Vehicles to Meet a fixed Periodic Schedule: An Application of Periodic Posets", *Operations Research*, Vol. 30, No. 4, pp. 760-776.
- Nemhauser, G. L. and L. A. Wolsey (1988), *Integer and Combinatorial Optimization*, John Wiley & Sons, Inc.
- Padberg, M. and G. Rinaldi (1987), "Optimization of a 532-City Symmetric Traveling Salesman Problem by Branch and Cut", *Operations Research Letters*, Vol. 6, No. 1.
- Parker, R.G. and R.L. Rardin (1988), *Discrete Optimization*, Academic Press, San Diego.
- Peiser, R.B. and S.G. Andrus (1983), "Phasing of Income-Producing Real Estate", *Interfaces*, Vol. 13, No. 5 (Oct), pp. 1-9.
- Perold, A. F. (1984), "Large Scale Portfolio Optimization", *Management Science*, Vol. 30, pp. 1143-1160.
- Plane, D. R. and T. E. Hendrick (1977), "Mathematical Programming and the Location of Fire Companies for the Denver Fire Department", *Operations Research*, Vol. 25, No. 4 (July-August), pp. 563-578.
- Pritzker, A., L. Watters, and P. Wolfe (1969), "Multiproject Scheduling with Limited Resources: a Zero-One Programming Approach", *Management Science*, Vol. 16, No. 1 (Sept.), pp. 93-108.
- Puterman, M. L. (1994), *Markov Decision Processes: Discrete Stochastic Dynamic Programming*, Wiley.
- Quinn, P., B. Andrews, and H. Parsons(1991) "Allocating Telecommunications Resources at L.L. Bean, Inc.", *Interfaces*, vol. 21, no. 1, pp. 75-91.
- Rardin, R. L. (1998), *Optimization in Operations Research*, Prentice Hall, New Jersey.
- Rigby, B., L. Lasdon, and A. Waren (1995), "The Evolution of Texaco's Blending Systems: From Omega to StarBlend", *Interfaces*, Vol. 25, No. 5, pp. 64-83.
- Roache, P. J.(1998), *Verification and Validation in Computational Science and Engineering*, Hermosa, NM. ISBN 0-913478-08-3.

- Rogers, D.F., R.D. Plante, R.T. Wong, and J.R. Evans (1991), "Aggregation and Disaggregation Techniques and Methodology in Optimization", *Operations Research*, Vol. 39, No. 4 (July-August), pp. 553-582.
- Ross, G. T. and R. M. Soland (1975), "Modeling Facility Location Problems as Generalized Assignment Problems", *Management Science*, Vol. 24, pp. 345-357.
- Rosenthal, R. and R. Riefel (1994), "Optimal Order-Picking", Bulletin for the ORSA/TIMS Detroit Meeting, INFORMS, Baltimore, MD.
- Rothstein, M. (1985), "OR and the Airline Overbooking Problem", *Operations Research*, Vol. 33, No. 2 (March-April), pp. 237-248.
- Roy, A. D. (1952), "Safety First and the Holding of Assets", *Econometrica*, Vol. 20 (July), pp. 431-439.
- Samuelson, D.(1999), "Predictive Dialing for Outbound Telephone Call Centers", *Interfaces*, vol. 29, no. 5,(Sept-Oct), pp. 66-81.
- Sankaran, J. (1989), *Bidding Systems for Certain Nonmarket Allocations of Indivisible Items*, Ph.D. dissertation, University of Chicago.
- Schrage, L. (1975), "Implicit Representation of Variable Upper Bounds in Linear Programming", *Mathematical Programming*, Study 4, pp. 118-132.
- Schrage, L. (1978), "Implicit Representation of Generalized Variable Upper Bounds in Linear Programming", *Mathematical Programming*, Vol. 14, No. 1, pp. 11-20.
- Schrage, L. and L. Wolsey (1985), "Sensitivity Analysis for Branch-and-bound Integer Programming", *Operations Research*, Vol. 33, No. 5 (Sept., Oct.), pp. 1008-1023.
- Schrijver, A. (1986), *Theory of Linear and Integer Programming*, John Wiley & Sons, Ltd.
- Schuster, E.W. and S.J. Allen (1998), "Raw Material Management at Welch's, Inc." *Interfaces*, vol. 28, no. 5, pp. 13-24.
- Serafini, P. (1996), "Scheduling Jobs on Several Machines with the Job Splitting Property", *Operations Research*, Vol. 44, No. 4, (July-August), pp. 617-628.
- Sexton, T.R., S. Sleeper, and R. E. Taggart, Jr. (1994), "Improving Pupil Transportation in North Carolina", *Interfaces*, Vol. 24, No. 1 (Jan.-Feb.), pp. 87-103.
- Sharpe, W. F. (1963), "A Simplified Model for Portfolio Analysis", *Management Science*, Vol. 9 (Jan.), pp. 277-293.
- Sherali, H., and W. Adams(1999), *A Reformulation-Linearization Technique for Solving Discrete and Continuous Nonconvex Problems*, Kluwer Academic Publishers, Dordrecht, The Netherlands.
- Sherbrooke, C.C. (1992), *Optimal Inventory Modeling of Systems, Multi-echelon Techniques*, John Wiley & Sons, New York, NY.
- Sherman, H. D., and G. Ladino (1995), "Managing Bank Productivity Using Data Envelopment Analysis (DEA)", *Interfaces*, Vol. 25, No. 2 (March-April), pp. 60-73.

- Shlifer, E. and Y. Vardi (1975), "An Airline Overbooking Policy," *Transportation Science*, Vol. 9, No. 2 (May), pp. 101-114.
- Srinivasan, V. (1976), "Linear Programming Computational Procedures for Ordinal Regression", *Journal of ACM*, Vol. 23, No. 3 (July), pp. 475-487.
- Steinberg, L. (1961), "The Backboard Wiring Problem: A Placement Algorithm", *SIAM Review*, Vol. 3, pp. 37-50.
- Stern, G. and R. Blumenstein (1996), "GM Expands Plan to Speed Cars to Buyers", *Wall Street Journal*, 21 October, p. A3.
- Stigler, G. (1963), "United States vs. Loew's, Inc: A Note on Block Booking", *Supreme Court Review*, p. 152.
- Stigler, G. J (1945), "The Cost of Subsistence", *Journal of Farm Economics*, Vol. 27, No. 2 (May), pp. 303-314.
- Stone, J.C. (1988), "Formulation and Solution of Economic Equilibrium Problems", Tech. Report. SOL. 88-7. Stanford University.
- Strevell, M. and P. Chong (1985), "Gambling on Vacation", *Interfaces*, Vol. 15, No. 2 (March-April), pp. 63-67.
- Stroup, J.S., and R.D. Wollmer (1992), "A Fuel Management Model for the Airline Industry", *Operations Research*, Vol. 40, No. 2 (March-April), pp. 229-237.
- Subramanian, R.A., R.P. Scheff, J.D. Quillinan, D.S. Wiper, and R.E. Marsten (1994), "Coldstart: Fleet Assignment at Delta Air Lines", *Interfaces*, Vol. 24, No. 1 (Jan.-Feb.), pp. 104-120.
- Sze, D. Y. (1984), "A Queueing Model for Telephone Operator Staffing," *Operations Research*, Vol. 32, No. 2 (March-April), pp. 229-249.
- Thompson, R. G., F. D. Singleton, R. M. Thrall and B. A. Smith (1986), "Comparative Site Evaluations for Locating a High-Energy Physics Lab in Texas", *Interfaces*, Vol. 16, pp. 35-49.
- Tomlin, J. and J. S. Welch (1985), "Integration of a Primal Simplex Algorithm with a Large Scale Mathematical Programming System", *ACM Trans. Math. Software*, Vol. 11, pp. 1-11.
- Troutt, M.D (1985), "Spying on the Cost Structure of Naive Bidding Competitors via Linear Programming Models", *Operations Research Letters*, Vol. 4, No. 4, pp. 181-184.
- Truemper, K. (1976), "An Efficient Scaling Procedure for Gains Networks", *Networks*, Vol. 6, pp. 151-160.
- Vickrey, W. (1961), "Counterspeculation, Auctions, and Competitive Sealed Tenders", *Journal of Finance*, Vol. 16, No. 1 (March), pp. 8-37.
- Wagner, H. M. and T. M. Whitin (1958), "Dynamic Version of the Economic Lot-Size Model", *Management Science*, Vol. 5, No. 1, pp. 89-96.
- Wall Street Journal*, "UAL's United Alters Schedule, Cuts Costs, Boosts Flights in Face of Discount Fares", (19 June, 1978), p. 8.
- Wang, K.C.P. and J.P. Zaniewski (1996), "20/30 Hindsight: The New Pavement Optimization in the Arizona State Highway Network", *Interfaces*, Vol. 26, No. 3 (May-June), pp. 77-89.

- Warner, D. M. (1976), "Scheduling Nursing Personnel According to Nursing Preference: A Mathematical Programming Approach", *Operations Research*, Vol. 24, No. 5 (September-October), pp. 842-856.
- Weingartner, H. M. (1972), "Municipal Bond Coupon Schedules with Limitations on the Number of Coupons", *Management Science*, Vol. 19, No. 4 (Dec.), pp. 369-378.
- What's Best User Manual*. LINDO Systems, Chicago, (1998).
- Whitt, W.(1993), "Approximations for the GI/G/m Queue", *Production and Operations Management*, vol. 2. no. 2, pp. 114-161.
- Wolsey, L.(1998), "Integer Programming", *Wiley Interscience*, New York.

INDEX

- !**
! mark comment, 30
- @**
@ functions, 94, 97, 114, 261, 495, 515, 516
@NEWLINE, 563
@TEXT() function, 563
@WRITEFOR function, 563
- 1**
100% rule, 43–44, 43
1-set patterns, 122
- 2**
2D cutting stock, 123
2-matching, 487
- A**
ABC's of modeling, 56
Abdulkadiroglu, A., 487
ABOUT LINGO, 29
absolute value, 202–3
accounting constraint, 56
accurate response, 519
Acharya, S., 168
Acie Knielson, 137
Acknowledgments, xiii–xiv
activities, 1
activity/resource diagram, 164, 178–80
activity-on-arc, 149–50, 190
activity-on-node, 149–50
ad hoc procedures, 124
Adams, J.L., 222
Adams, W., 297
additively separable, 271
additivity, 5
adjustable cells, 56
advertising, 414, 475
advertising brochures, 132
advertising decision, 474
aggregation, 557, 566–68
Air Force, 165
Airbus 320, 128
aircraft, 123
aircraft fuel ferrying, 189
airline, 60, 123, 168, 191, 193, 223, 325, 398, 502, 515
airline hub, 281
airline industry, 164
airline terminal, 296
Alaska Airlines, 428, 429
Alcohol, Tobacco, and Firearms, Dept. of, 253
Alirezace, M., 429
all units discount, 270
Allen, S. J., 228
allocated cost, 60
allocation of profit, 37
allowable increase/decrease, 39
alternate optima, 13, 412, 417–18
alternative formulation, 99, 102
alternative solution, 479
America West Airline, 428
American Airlines, 281
American Metal Fabricating Company, 103
American option, 356, 361
American Petroleum Institute, 241
Amin, G., 429
amperes, 465
AND operator, 323
Andrews, B., 532
Andrus, S.G., 217
Ann Klein, 499
API gravity, 241
apparel firm, 519
apple, 439
approximation, 557
arbitrage, 398, 441
arc, 143
arithmetic mean, 239, 255
Arizona, 364
Arnold Line, 475
ARRANGE ICONS, 28
ash, 227, 250, 303
assignment problem, 144, 281–99, 300–303
asymmetric risk measure, 404
ATM, 541
attribute, 71
auction, 326, 447–51, 469
auditability, 95
auto industry, 508
Automated Teller Machine, 541

automobile, 330, 515
 automobile industry, 386
 AUTOUPDATE, 29
 average cost, 364
 Aviston Electronics, 109

B

backlog, 562
 backlogged demand, 513
 backup supply agreement, 499–501
 baggage, 281
 balance sheet, 227
 Balas, E., 267
 balk, 534
 balking, 549
 bank, 227
 banking, 327, 435
 Banks, J., 555
 barge, 303
 Barnett, A., 428
 baseball, 285
 base-stock policy, 512–15, 539
 batch size constraint, 262–63
 beans, 337
 Beckmann, M., 297
 benchmark portfolio, 398, 399–406, 404
 benchmark study, 437
 Benetton, 499
 Bessent, A., 433
 Bessent, W., 433
 beverages, 294
 bicycle, 529
 bid-ask spread, 380
 bidding system, 189
 Big Mac, 256
 bilingual, 138
 bimatrix game, 474
 BIN function, 94
 binary integers, 30
 binary representation of a general integer, 262
 binary variable, 94, 262
 binomial distribution, 501
 binomial pricing, 356
 binomial tree model, 357–60
 Birge, J. R., 336
 Black & Scholes model, 356
 black market, 454
 Black, F., 356, 357, 558
 Black/Derman/Toy model, 358
 blending, 227–58
 blending facility, 560

blending, multi-level, 243
 Blockbuster, 332
 bluffing, 558
 Blumenstein, R., 515
 BND() function, 94
 Boeing 747, 128
 bond, 224
 bond market, 356
 bond portfolio, 203
 book value, 61, 66
 Boole, G., 262
 Boolean variables, 262
 borrow, 225
 Bosch, R.A., 256
 Bracken, J., 186
 Bradley, G., 141
 Bradley, S., 43
 Braess, D., 463
 Braess's Paradox, 463
 branch and bound method, 272
 branch banking, 327
 Bratley, P., 352
 Brearley, A.L., 565
 broker, 447
 Brompton bicycle, 529
 Brown, G., 141, 198, 324
 BTU, 227, 250, 256, 303
 build-out problem, 57
 bulk mail, 132
 bundle pricing, 320, 451–57
 Buster Sod, 109
 buyer behavior, 451
 byproduct, 60

C

Cabernet Sauvignon, 253
 cabin attendant, 128
 calcium, 256
 California, 253
 call center, 114, 532
 calorie, 256
 Canada, 441, 483
 capacitated plant location problem, 265–70
 capacity planning, 531, 532
 capital gain, 382
 caplet, 360
 carbohydrate, 227
 Carino, D.R., 217, 352
 CASCADE, 28
 cash balance management, 365–68
 cash flow constraint, 208

- cash flow matching, 203–7, 224
- casino, 346
- cassette, 332
- catalog, 493, 496
- centistokes, 241
- CEO, 559
- cereal, 198
- certainty equivalence, 345–46
- chance-constrained program, 368
- Charnes, A., 433
- checkerboard, 331
- cheese, 197
- chemical industry, 240
- chess, 182
- Chevrolet, 261
- Chicago, 447
- chicken, game of, 480
- chief financial officer, 335
- chip design, 296
- chips, electronic, 182
- chocolate, 432
- Cholesky factorization, 272, 352, 407–8
- Chrysler, 507
- circuit board, 283, 296, 300
- circuit board routing, 300
- circuits in networks, 164
- Clarke, G., 290
- Claus, A., 284
- Clay Mathematics Institute, 275
- clearing price, 448, 455
- CLOSE, 24
- CLOSE ALL, 28
- Clue (game of), 333
- coach class, 503
- coal, 227, 250, 256, 303
- coal-fired unit, 217
- coalition, 482
- Codd, E.F.*, 69
- coefficient of variation, 496
- college, 487
- college admissions, 483
- column generation, 309, 571, 576
- combinatorial auction, 469
- COMMAND WINDOW, 28
- Commands, 23–29
- comment, 30
- communication network, 164, 182
- complementary slackness condition, 38
- composite variable, 157, 159, 309
- computational difficulty, 46, 274–75
- computer controlled machine, 284
- concave function, 41
- congestion, 458
- conjoint analysis, 293
- conservation of flow, 465, 466
- constrained dynamic lot size problem, 521–29
- constrained optimization, 1
- constraint aggregation, 567
- constraint limit, 29
- constructive model formulation, 56–57
- continuity, 5
- Continuous review, 515
- convex function, 41
- convex region, 423
- Cooldot cutting stock, 116
- Cooper, W., 433
- cooperation, 482
- cooperative game, 481
- Copenhagen, 532
- copper, 45
- COPY, 25
- core of a game, 482, 487
- corn, 227, 337
- correlation, 372
- cost allocation, 60, 471–92
- cost of capital, 60
- costing out an activity, 35, 36–37
- coupon, 110
- course registration, 447
- covariance, 371
- covariance matrix, 396–97
- Coventry, 558
- coverage by test, 556
- coverage by tests, 556
- covering, 299
- covering models, 111–40
- covering problem, 332
 - reducing nonzeros, 569–71
- CPM, 55, 86, 144–49
- cranberry, 110
- crashing, 193
- crashing of projects, 144, 150–57
- Craven, J. P., 86
- creative, 577
- crewing basing constraints, 128
- Critical Path Method, 55, 86, 144–49
- cross of sets, 70
- cross-sectional aggregation, 557
- crude integer programming, 326
- Cumulative Load Formulation for TSP, 283
- currency exchange, 191
- CUT, 25
- cutting plane method, 272
- cutting stock, 115–23, 140, 300, 311, 572–76
- cycle inventory, 510
- cyclic problem, 217

cyclic vehicle routing, 222

D

Dalton, L., 332
 Dantzig, G., 159, 241
 Dantzig, G. B., 283
 Danusaputro, S., 283
 data envelopment analysis, 433–38
 DATA section, 73–75
 data set allocation, 327
 database, 95
 DATABASE USER INFO, 25
 databases, 75
 Dauch, D.E., 507
 Davis, L., 158
 DEA, 433–38
 deadheading, 125
 decision support system, 555–78
 decision variables, 568
 decomposition, 557
 defeasance of balance sheet, 203
 defect, 123
 definitional constraint, 56
 degeneracy, 11–18, 13, 16–18
 Deglo Toys, 57
 delivery, 300
 Dell, R., 198
 Delta Airlines, 168, 281
 demand requirements, 124
 Dembo, R., 336
 dense derived set, 83
 dense set, 71
 density, 240
 Department of Energy, 443
 depreciation, 211
 derived set, 71–72
 Derman, E., 357
 DeRosa, D., 361
 designing of reports, 560–61
 Deutsche Mark, 361
 developing the model, 556
 dimensional analysis, 63
 dimensional view of reports, 561
 Dines/Fourier/Motzkin elimination, 159
 disaster planning, 214
 disjunctive formulation, 267
 disk drive, 503
 disk file allocation, 296
 disk storage device, 327
 distribution center, 192, 292, 515
 distribution system, 141, 144

diversion matrix, 502
 dividends, 372, 382
 dormitory, 90
 double entry bookkeeping, 162–63
 Dow-Jones Industrial, 384
 downside risk, 347, 393–97
 dual degenerate, 16
 dual of network LP, 280
 dual price, 7, 8–9, 12, 13, 35–38, 267, 276, 562, 571, 576
 dual problem, 45–47
 dualing objectives, 375
 duality in networks, 149
 due date, 122
 dummy activity, 150
 duration, 254
 Dyckhoff, H., 121
 dynamic, 197
 dynamic lotsizing, 267, 521–29
 dynamic network, 214
 dynamic programming, 315, 356–57

E

East Germany, 441
 economic equilibria, 441–69
 economy of scale, 537
 edge waste, 115, 122
 Edie, L., 112
 Editing a Model, 30
 Efficient Benchmark Portfolio, 404–5
 efficient front, 375
 efficient frontier, 413, 416, 428–33
 efficient market, 389
 efficient points, mixed case, 432–33
 electric power industry, 217
 electrical distribution, 364
 electrical network, 463
 electrical utility, 325, 350
 electricity, 411, 465
 electronic circuit board, 283
 Ellis, C., 324
 Elshafei, A., 297
 end effect, 216–17
 end waste, 115, 122
 energy policy, 443
 entering a problem, 29–30
 enumeration tree, 273
 environmental interests, 412
 Eppen, G., 217, 355, 372, 386, 502, 522
 equilibrium network flows, 465–67
 equilibrium strategy, 476

equities, 163
 Erlang C model, 536
 Erlang loss model, 536
 Erlang, A. K., 532
 Erlang-B, 536
 error of approximation, 63
 error of formulation, 62–65
 European option, 356, 361
 evacuation, 214
 Evans, J.R., 557
 EVMU, 345
 EVPI, 344–45
 Excel, 95
 exchange rate option, 361–63
 exclamation mark, 30
 EXIT, 25
 expected value of modeling uncertainty, 345
 expected value of perfect information, 344–45
 exponential distribution, 533
 exposures in advertising, 414
 expressway repair, 152

F

fabric, 123
 face value, 204
 facility layout, 296
 Fahrenheit, 240
 farmer, 337, 398, 411
 fast food restaurant, 555
 feasible solution, 6, 133, 562
 feasible tour, 126
 Federal Express, 165
 federal regulation, 237
 feed, 227
 ferry, 475
 ferry fuel, 164
 fertilizer, 252
 Festus City staffing, 131
 fiber optic, 258
 Fields, C., 228
 file, 95
 file allocation, 296, 327
 Fillon, M., 412
 filter, 71
 financial, 203
 financial portfolio, 55
 financial agreement, 568
 financial index, 56
 financial industry, 254
 financial option, 356
 financial packing, 307

FIND, 26
 FIND NEXT, 26
 first class seat, 503
 first-order conditions, 247
 Fisher, M., 496, 519
 fisherman, 412
 fixed charge problem, 263
 fixed cost, 122
 flashpoint, 241
 fleet routing & assignment, 168–76, 218
 fleet sizing, 60
 flexible spending account, 530
 flood control, 412
 flooding, 335
 Florian, M., 461
 Flying Tiger Airlines, 124
 FOB, 508, 510
 food, 227
 football, 329
 forecast error, 507
 foreign exchange rate option, 361–63
 forest planning, 158
 forest products, 198
 formatted output, 563
 formulation, 126
 formulation of portfolio problems, 405–6
 Foster City, 207
 Fourier/Motzkin/Dines elimination, 159
 Fox, B., 352
 Fra Luca Pacioli, 162
 fractional answers, 121
 fractional programming, 242–43
 free variable, 94
 Freeport Community College, 139
 frequency assignment, 296
 fruit packing, 439
 FTL(Full Truck Load) routing problem., 168
 Fudenberg, D., 471
 fuel, 55, 254, 338
 fuel ferrying, 189
 fuel purchasing, 164
 fuel tank truck, 324
 Fulkerson, D. R., 283
 functional approximation, 557

G

Gaballa, A., 532
 Gale, D., 483
 gallons per mile, 237
 gambler, 346
 game theory, 56, 423, 471–92

gas-fired unit, 217
 gasoline, 61, 227, 331, 465
 gate assignment, 296
 general equilibrium model, 463
 general integer, 31, 94, 262
 General Motors, 55, 217, 502, 515
 generalized mean, 240–42
 generalized networks, 164
 GENERATE, 27
 Geoffrion, A., 157
 geometric mean, 239, 255
 German Mark, 361
 German writer, 469
 Germany, 441
 Gibson, R., 555
 GIN function, 30, 94, 114, 261
 glass, 123
 glass bottle, 441
 glass fiber, 241, 258
 global solver, 17, 457
 Glover, F., 443
 GO TO LINE, 26
 go/no-go, 262
 goal programming, 411–39, 416–22
 Goethe, 469
 Gould, F.J., 372
 government, 326
 government securities, 203
 grain, 227
 grain storage, 243
 Gram-Schmidt orthogonalization, 353
 grape juice, 228
 graphical analysis, 2–4
 Graves, G., 141, 157, 324
 Graves, R. L., 447
 gray market, 454
 greedy heuristic, 266
 Greenberg, H. J., 32
 Grinold, R., 216
 grocery store, 513
 Gross, D., 532
 Grötschel, M., 293
 grouping, 299, 332
 guess, 246
 guillotine cut, 123

H

Hadley, G., 179
 Haggard, M., 332
 Hamlet variable, 262
 Hansen, C., 465

Hanson, W., 320
 harmonic mean, 240, 255
 Harris, C., 532
 Haverly, C., 243
 Hax, A., 43
 health insurance, 58
 Heath, D., 357
 hedging, 398, 399
 Held, M., 315
 HELP TOPICS, 29
 heuristic, 266
 heuristic for TSP, 284
 heuristic procedures, 124
 Hewlett-Packard, 509
 Hidroeléctrica Española, 336
 high school ranking, 429
 highschool, 487
 highway maintenance, 364
 highway repair, 150
 hiring and firing cost, 199
 holdback agreement, 499
 holdback inventory, 519–21
 hospital, 20, 112, 483
 hotel, 567
 house of representatives, 422
 Houston, 433
 hub, 281
 hub system, 166
 hydroelectric, 214, 335
 hyperbolic programming, 242–43

I

IBM, 332
 IBM RS6000, 182
 Illinois, 227
 implementation, 555–78
 IMPORT LINDO FILE, 25
 importance sampling, 350
 inbound call center, 547
 incentive, 150
 incentive compatibility, 487
 incentive compatible, 483
 income tax, 211–16
 incremental units discount, 270
 inequalities, 29
 Infanger, G., 336, 350, 386
 infeasible formulation, 10–11
 INIT section, 246
 initial guess, 246
 initialization, 246
 input data, 565

input-output matrix, 293
input-output model, 55, 176
INSERT NEW OBJECT, 26
integer programming, 30–32, 261–333, 576
integral Leontief, 276
integrality restriction, 114
intelligent enumeration, 272
interest rate option, 357
internal rate of return, 210
Internal Revenue Service, 225
international affairs, 471
inventory, 493
inventory balance constraint, 217
inventory positioning, 516
inventory restrictions, 122
inventory turns, 535
inventory variable, 197, 198
investment, 371
iron, 256
irrigation, 109
Irving, R., 487
Islandia, 176
iso-cost line, 3
iso-profit line, 3

J

J.P. Morgan, 391
Jahanshahloo, G., 429
Jarrow, R., 357
Jeroslow, R., 164, 276
jet fuel, 241
jobshop scheduling, 155
Johnson, K., 158
Johnson, S. M., 283
join of sets, 70
joint cost, 58, 60
joint product, 60–62
Jorion, P., 391

K

Kall, P., 336
Karp, R., 315
Karush, W., 38
Kasparov, G., 182
Kehoe, T.J., 456, 457
Kelly-Springfield Tire Company, 522
Kennington, J., 433
Kernighan, B., 284
Khachian, L., 275
kidney donor, 483

Killion, C.L., 124
King, R.H., 522
KISS (Keep It Simple,...), 556
KKT condition, 37–38
Klingman, D., 443
knapsack, 574, 576
Kontogiorgis, S., 168
Koopmans, T., 297
Kruskal, W., 181
Kuhn, H., 38

L

L.L. Bean, 493, 532
labor contract, 58
labor market, 483
Ladino, G., 435
Lagrange multiplier, 37–38
lakefront, 481
Lands End Outlet store, 496
Lasdon, L., 237, 240, 522
Lawler, E., 283
lead time, 214, 507
leap year, 561
Lee, C., 283
Leontief flow, 164, 176–78
Leontief LP, 276
Leontief, W., 55, 164
Less than TruckLoad, 289
less-is-better, 430–32
lexico goal programming, 419–22
lexico minimization, 422–27
liabilities, 163
LICENSE, 25
Lin, S., 284
Lincoln Tunnel, 112
linear complementarity problem, 474, 477
linear loss function, 495
linear loss function, Poisson, 515
linear ordering, 293–95
Linear Products Company, 529
linear programming, 1, 116
linearity, 5–6
linearization, 240
linearizing products of variables, 316–23
LINKS, 27
Linux, 23
LIST OF WINDOWS, 28
littering, 441
Little's equation, 535
Liz Claiborne, 499
loan, 227

local optimal, 247
 local optimum, 17
 lockbox location, 264
 log, 262
 LOG OUTPUT, 24
 logical expression, 323–24
 LOOK, 28
 loose formulation, 266
 lost sales, 502, 514
 lotsizing, 493
 lottery, 140, 332
 Love, R.R., 522
 lower bound, 94
 lower triangular matrix, 407
 LTL, 289
 lumber, 66

M

Mackinac Island, 475
 Mackinaw City, 475
 MAD, 396
 Madansky, A., 386
 Madsen, K., 465
 Magnanti, T., 43
 mail order, 139
 mail processing, 132
 mailing lists, 131, 138
 maintenance, 176, 364
 maintenance of a model, 556
 make-or-buy, 262
 Manne, A., 364
 map coloring, 300
 marginal analysis, 494, 497, 499
 Mark, German, 361
 market factor, 384
 market share, 490
 market value, 61
 marketing, 139, 293, 471
 marketing the model, 559–63
 Markov decision process, 364
 Markowitz, H., 371
 marriage problem, 483
 Marsten, R.E., 124
 Martin, K., 32, 159, 164, 217, 267, 275, 276, 320, 355, 386, 502, 522
 Martin-Vega, L., 283
 Maschler, M., 423
 mass mailing, 131
 mastermind, 328
 MATCH PARENTHESIS, 26
 match the covariance matrix, 396
 matching, 90, 299, 399
 matching portfolio, 398
 matching scenarios to targets, 351
 material balance, 197
 material requirements planning, 164, 522
 mathematical programming, 1
 matrix generation, 565
 maximal flow, 144
 McCormick, G., 186
 McDonald's restaurant, 257
 McGee, E., 228
 McVitie, D., 486
 mean absolute deviation, 396
mean time between failures, 533
 measure of risk, 389–93
 media selection, 413
 medical expense, 530
 Mehrabian, S., 429
 membership filter, 71, 90–94
 memory limit, 29
 memoryless property, 534
 metal, 227
 METRIC model, 515–18
 Mexico, 441
 Michigan, 475
 Microsoft Windows, 95
 miles per gallon, 237, 254
 military combat, 471
 Millennium prize, 275
 Miller, C. E., 284
 milling in transit, 157
 milling-in-transit, 158
 minimax hurt, 422–27
 minimax strategy, 472–74
 minimum spanning tree, 293
 Mitra, G., 565
 mixed strategy, 473, 476
 Mobil Oil, 324
 model formulation, 53–67
 Model I approach, 158
 Model II approach, 159
 MODEL STATISTICS, 27
 moisture, 227, 250, 303
 Moldovanu, B., 469
 Moore, G., 132
 more-is-better, 428–30
 Morton, A., 357
 Mother's Day, 159
 motorists, 152
 Motzkin/Dines/Fourier elimination, 159
 movie distributor, 320
 MPS FILE, 25
 MRP, 164, 276, 522

MTBF, 533
 Muller, M.P., 124
 Multi-commodity Flow Formulation for TSP, 284
 multicommodity network, 164–65
 multi-echelon base stock, 515–18
 multiperiod network, 214
 multiperiod planning, 197, 335
 multiple criteria, 411–39, 442
 multiple optima, 11–18, 16, 479
 multiple rates of return, 210
 multiple skills, 114
 multiplicative, 5
 multiproduct inventory, 502–6
 multiproduct lot sizing, 521–29
 multi-stage newsvendor, 496–506
 Multisys, Inc., 503
 Murchland, J. D., 463
 music, 332

N

NAFTA, 441
 Nahmias, S., 507, 509
 Nash equilibrium, 477
 National League, 285
 National Resident Matching Program, 483
 natural gas, 224
 natural gas pipeline, 164
 naturally integer, 141, 279–80
 naval petroleum reserve, 326
 navigation, 335
 NBA basketball draft, 491
 negotiation, 471
 Nelson, W., 332
 Nemhauser, G., 272
 nervousness, 198
 net worth, 209
 network LPs, 55, 143, 276
 Model I approach, 158
 Model II approach, 159
 network with gains, 164
 networks, 141–95, 463
 NEW, 23
 New York, 487
 New York Port Authority, 112
 news vendor problem, 493–96, 493, 494, 503
 newspaper, 289
 niacin, 257
 Nielsen, H. B., 465
 Nikkei index, 384
 nitrogen, 252
 no feasible solution, 6, 10

Nobel Prize, 377
 node, 143
 non-constant sum game, 474–81
 nonlinear network, 186–88
 nonlinear profit function, 99
 nonlinear program, 202
 non-optimal behavior, 218
 non-optimal solutions, 558
 nonsimultaneity error, 65
 Normal distribution, 495, 501
Normal form, 69
 Northeast Tollway staffing, 112–15, 134
 Norway, 483
NP-complete, 275
 n-person game, 481
NP-hard, 275
 NRMP, 483
 nucleolus, 423

O

oats, 227
 Obermeyer, 496, 519
 Object Linking and Embedding, 95
 OBJECT PROPERTIES, 27
 octane, 227
 ODBC, 25, 75, 95, 97
 ohms, 465
 OLE, 95
 Omaha, NE, 114
 one hundred % rule, 43–44
 one-time study, 556
 on-the-fly column generation, 571–76, 574
 OPEN, 24
 Open Database Connectivity, 95
 optical instrument, 135
 optimal solution, 576
 option, 356
 optional stop TSP, 289
 OPTIONS, 27
 OR operator, 323
 order splitting costs, 122
 origin/destination pair, 164
 Orlin, J., 222
 orthogonalization, 353
 overage, 122
 overbooking, 501, 556
 overstaffing, 115
 overtime, 151, 223

P

- packing, 299, 330
- packing problem, 303–16
- Padberg, M., 284
- painting of cars, 283
- pairing, 125
- pairwise comparison, 294
- paper, 115
- paper industry, 311
- Pap-Iris Company, 132
- paradox, 463
- parametric analysis, 375–79
- parent set, 71
- Pareto optimal, 412, 461
- parking garage, 501
- Parsons, H., 532
- partitioning, 299
- part-time help, 137
- PASTE, 25
- PASTE FUNCTION, 26
- PASTE SPECIAL, 25
- path formulation, 157–59, 309
- Pathak, P., 487
- patient distribution, 165
- pattern pairing, 123
- pattern selection, 115–23
- Pearce, W., 532
- Peiser, R.B., 217
- Peleg, B., 423
- Pennsylvania, 227
- pension fund, 203
- perfect information, 344
- perfume industry, 45
- periodic review, 513
- perishable product, 217
- Perold, A., 386
- personal injury lawsuit, 203
- PERT, 55, 85
- PERT/CPM, 141, 144–49
- petroleum, 198, 243, 331
- petroleum industry, 1
- petroleum reserve, 471
- phase-out problem, 66
- Phoenix, 428
- phone, 194
- phosphorous, 252
- picture, 142
- PICTURE, 27
- piecewise linear, 268
- PIES, 443
- pilot, 128, 223
- pipeline, 243
- pipeline inventory, 508, 509
- planning horizon, 58, 217
- plant location and vehicle routing, 292
- plant location problem, 263–64
- Plante, R.D., 557
- plastic wrap, 115, 123
- plywood, 66
- Poisson distribution, 501, 515
- poker, 558
- Polaris submarine, 86
- political candidate, 138
- political events, 336
- political organization, 131
- pooling, 243–48
- portfolio models, 371–409
- Postal Optimality Analysis, 132
- postponeable demand, 115
- postprocessing/disaggregation, 566, 568
- potash, 252
- PPL() function, 515, 516
- prayer algorithm, 275–80
- predictive dialing, 541
- preemptive goal programming, 419–22
- preemptive objective, 411
- Preface, xiii–xiv
- present value, 203, 210
- pressure drop, 466
- price strategy, 471
- primal degenerate, 16
- primitive set, 70–71
- print*, 24, 509
- PRINT, 24
- PRINTER PREVIEW, 24
- PRINTER SETUP, 24
- prisoner's dilemma, 475–76
- Pritzker, A., 155
- probability, 140, 186, 241
- process selection, 103–7
- product mix, 1–4, 99–110
- product of variables, 271
- Program Evaluation and Review Technique, 55, 144–49
- program trading, 398
- proportional representation, 422
- proportionality, 5
- protein, 227, 256
- PSL() function, 495
- public service organizations, 131
- pumpkins, 60
- pure integer program, 261
- pure strategy, 472
- Puterman, M., 364

puzzle, 328, 333, 563

Q

Q,r model, 507–12
 Qantas Airline, 532
 quadratic assignment problem, 296–99
 quadratic programming, 371
 quadratic utility function, 393
 quality, 227, 237–39
 quality measure, 240
 quantity discount, 5, 268, 454
 queue discipline, 532
 queuing theory, 139, 532–35
 Quinn, P., 532

R

R. R. Bean, 139
 Raborn, W. F., 86
 radio frequency assignment, 296
 radio frequency spectrum, 469
 railroad, 19
 Raman, A., 496, 519
 ranch, 469
 random strategy, 472, 476
 random variable, 55
 RANGE, 27
 range analysis, 35, 38–44
 range name, 95
 ranking, 293, 294
 Rardin, R., 164
 Reagan, B., 433
 real estate, 469
 recapture of lost demand, 502
 recreational interests, 412
 recycling, 45
 reduced cost, 7, 8–9, 13, 35–38
 reducing model size, 563–71
 reducing nonzeros, 569
 redundant constraint, 16–18
 reference solution, 198
 refinery, 243
 REGISTER, 29
 Reid vapor pressure, 240
 reneging, 534, 549
 rented vehicles, 176
 REPLACE, 26
 report format, 56, 563
 reports, 559–63
 reports in LINGO, 563
 resistance, 465

resource constraints, 155
 resources, 1
 restaurant, 543
 return, 371
 revenue management, 191
 Rhodes, E., 433
 riboflavin, 257
 Riefel, R., 253
 Rigby, B., 237, 240
 Rinaldi, G., 284
 risk, 371
 risk averse, 346–50, 389
 risk-free asset, 375–77
 RiskMetrics, 391
 river shipping, 411
 Roache, P.J., 556
 road network, 182
 Rogers, D.F., 557
 rolling format, 197
 Ronen, D., 324
 room scheduling, 567
 roommate assignment, 300, 301
 roommate problem, 90
 room-mate problem, 487
 Rose, P., 285
 Rosenthal, R., 253
 rostering, 114, 128
 rotation, 125
 Roth, A., 483, 487
 Rothblum, U., 487
 Rothstein, M., 556
 Rotorua, 439
 roulette, 346
 rounding up heuristic, 576
 round-up feature/cutting stock, 140
 routing, 111, 168, 289–92
 row aggregation, 566
 row generation, 576
 row operation, 276, 279
 Roy, A., 371
 royalty fee, 469

S

S&P 500, 56, 372, 384, 398, 399
 safety lotsize, 501–2
 salt, 338
 salvage value, 217
 Sampson, R., 491
 Samuelson, D., 541
 San Francisco, 428
 Sankaran, J., 423

- Sarrafzadeh, M., 296
 Savage, S., 56
 SAVE, 24
 SAVE AS, 24
 Saving a Model, 30
 savings account, 203
 Sayre-Priors Airline, 124, 134
 scalability, 95
 scaling, 32
 scaling networks with gains, 164
 scenario approach, 267, 336–38, 386–87, 402–4
 Schmidt, C., 372
 Scholes, M., 356
 school assignment, 265
 school ranking, 429
 Schrage, L., 217, 352, 355, 386, 502
 Schuster, E. W., 228
 Schwindle Cycle Company, 277–79
 scoring, 434
 Scotland, 483
 seasonal product, 493
 Seattle, 428
 seawall, 481
 secondary objective, 198
 second-shift labor, 151
 security level, 331
 segregated storage, 324
 SELECT ALL, 26
 SELECT FONT, 26
 sell crude oil, 326
 semicolon, 30
 semiconductor manufacture, 501
 semi-continuous variable, 263
 semi-variance, 394–96
 SEND TO BACK, 28
 sensitivity analysis, 8–9
 sensitivity analysis of constraint coefficients, 44–45
 separable function, 271–72
 separation of data and system structure, 558–59
 separation theorem, 377
 sequencing, 122, 284, 293
 Serafini, P., 422
 service industries, 111–40
 service system, 531–54
 set partitioning, 129
 sets, 69–98
 covering, 129
 packing, 129
 sewer lines, 182
 Sexton, T.R., 435
 Shapley value, 483
 Shapley, L., 423, 483
 Sharpe ratio, 378–79
 Sharpe, W., 384
 shelf life constraints, 217
 shelf space allocation, 513
 Sheplers, 475
 Sherali, H., 297
 Sherbrooke, C.C., 516, 518
 Sherman, H.D., 435
 ship scheduling, 198, 557
 Shmuzzles, 66
 shoe factory, 559
 shortest/longest path, 144
 sign convention, 8
 signing off on system structure, 562–63
 silo, 324
 simple lower bound, 94
 simple upper bound, 46, 94
 simplex method, 141
 Singapore, 483
 single-sourcing, 265
 ski parka, 493
 slack variables, 12
 sliding format, 197
 slow moving item, 515
 Snake Eyes condition, 13–16
 snicker test, 561
 snow removal, 369
 social optimum, 461–63
 Social Security, 58
 soft constraints, 416–22
 software, 556
 solution, 121
 SOLUTION, 27
 solution analysis, 6–7
 solution report, 7, 35
 SOLVE, 27
 solving a model, 30, 32
 Sonmez, T., 483
 sorghum, 337
 sources = uses, 56, 142, 197, 200
 soybeans, 227
 Spanish, 138
 spanning tree, 180–82, 293
 sparse set, 71, 90–94
 specific gravity, 241
 spill, 502
 split the pie, 471
 Sport Obermeyer, 496, 519
 sport utility vehicle, 438
 sports tournaments, 293
 spreadsheets, 94–97
 SQL interface, 97
 SR-71, 241
 St. Libory Quarry, 134

- stable marriage problem, 483
 stable room-mate problem, 487
 stable solution, 476
 Stackelberg equilibrium, 454, 480
 staffing, 223, 417, 532
 staffing column generation, 571
 staffing problem, 111–15, 131, 136
 Standard and Poor's, 372
 Star Line, 475
 startup and shutdown costs, 217
 stationarity, 535
 stationary point, 247
 statistical approximation, 557
 statistical economy of scale, 537
 Statistics of a model, 27
 STATUS WINDOW, 28
 steady state, 535
 steel industry, 311
 Steinberg, L., 296
 Steiner tree, 182–85
 Stern, G., 515
 Stigler, G., 228, 257, 320
 stochastic program, 55
 stock market, 356
 stock option, 356
 stockouts, 502
 storage, 224
 strict inequality, 29
 strike price, 356
 Stroup, J., 164
 Stuttgart, Germany, 463
 submarine, 85
 Subramanian, R., 168
 substitution of demand, 502
 subtour, 290
 Subtour Elimination Formulation for TSP, 283
 Sudoku puzzle, 563
 sulfur, 227, 243, 250, 303
 sunk cost, 58, 61
 superworker, 562
 supply chain, 158, 493–530, 499
 surgical, 20
 symmetric distribution, 389
 symmetric TSP, 285
 symmetry, 301
- T**
- TAKE COMMANDS, 24
 tank truck, 324, 331
 tax, 60, 207, 224, 382–83, 530, 568
 tax (social security), 58
 telephone, 112, 138, 532, 555
 template approach, 54–56
 temporal aggregation, 557
 Terjung, R.C., 522
 terminal, 296
 Texaco, 237, 240
 TEXT() function, 97
 textiles, 115
 Thapa, N., 241
 thiamine, 257
 Three Gorges dam, 412
 three R's, 429
 tide, 557
 Tietzel, M., 469
 tight formulation, 266, 274
 TILE, 28
 timber, 66
 Tiny Timber, 66
 tire molding, 522
 Tirole, J., 471
 Tobin, J., 377
 toll booth staffing, 112
 tolling, 45
 tour, 125, 126
 Toy, W., 357
 tracking portfolio, 398
 trade barrier, 455
 trade-off curve, 413
 traffic, 458
 train station, 296
 transmissivity, 241, 258
 transportation equilibria, 457–63
 transportation organizations, 131
 transportation problem, 144
 transpose, 46
 traveling salesperson problem, 283–89
 treasury bills, 375
 tree for branch-and-bound, 273
 trim waste, 116, 118
 truck, 331
 truck terminal, 296
 trucking, 168
 trucking firm, 60
 Truemper, K., 164
 truncation., 217
 Tucker, A., 38
 Tucker, A. W., 284
 two-person game, 471–74
 two-sided constraints, 234–37
 type wheel design, 297
 typographical error, 7, 63

U

U. S. Air Force, 516
 U.S. Postal Service, 132
 unbounded formulations, 9
 unbounded solution, 7
 uncertainty, 335–70
 Uncommon Result, 131
 underage, 122
 undirected network, 159–62, 164
 UNDO, 25
 unit commitment problem, 217, 325
 United Airlines, 168, 281
 United States, 441
 University of Chicago, 447
 Unix, 23
 unordered lexico minimization, 422–27
 unordered pairs, 302
 Unver, M., 483
 upgrading costs, 122
 upper bound, 94
 US Airways, 168
 user equilibrium, 461–63
 utility function, 412
 utility maximization, 451

V

validation, 556–58, 557
 Value at Risk, 391–92
 Vande Vate, J., 484
 Vanguard, 382, 398
 vapor pressure, 227, 240
 VAR, 391–92
 variable aggregation, 567
 variable cost, 58–60
 variable domain function, 94
 variable limit, 29
 variance, 347, 371
 VBA program, 97
 vehicle routing, 222, 289–92, 315
 verification, 556–58, 577
 vertex solution, 248
 vertically integrated, 178
 vertically integrated model, 55
 vintage, 227
 viscosity, 241
 vitamin, 256
 VLSI, 182, 296
 volatility, 227, 558
 voltage, 463, 465

W

Wagner, H., 521
 Wall Street Journal, 357
 Wallace, S.W., 336
 Wang, J., 164
 Wang, K.C.P., 364
 Wardrop's Principle, 457
 warehouse, 142
 Waren, A., 237, 240
 water, 465
 water lines, 182
 WATS, 537
 Watters, L., 155
 weapons assignment problem, 186
 weather, 335
 Welch's, Inc., 228
 West Germany, 441
 What's*Best!*, 558
 Wheatstone bridge, 464
 Whitin, T., 521
 Whitt, W., 543
 Williams, H., 332, 565
 Wilson, L., 486
 Windows, 95
 wine, 227, 253
 Winston-Salem Development Management, 208–9
 Wolfe, P., 155
 Wollmer, R., 164
 Wolsey, L., 272
 Wong, C., 296
 Wong, R.T., 557
 wood, 123
 Wood, K., 198
 work in process inventory, 122
 World War II, 558
 worst case behavior, 275
 WRAP function, 82, 114
 Wright, J.W., 290
 Wyoming, 227

Y

Yangtze river, 411
 Yasuda-Kasai, 217, 352
 yield curve for bonds, 358
 yield management, 191
 Young, N., 332

Z

Zaniewski, J.P., 364

Zemlin, R. A., 284
zero sum game, 474

zero/one variable, 94
Zzyzx Company, 266